

بِسْمِ اللّٰهِ الرَّحْمٰنِ الرَّحِیْمِ



ދިވެހިރާއްޖޭގެ ޖަޒާއިރުގެ ގަޒެޓް

Volume: 54

Issue: 10

Date: 15 Rajab 1446 – 15 January 2025

Wednesday

Regulation No: 2025/R-8

MCAR-M Continuing Airworthiness

The President's Office
Boduthakurufaanu Magu
Male, Maldives'

Phone: 3336211

Mobile: 7242885

Website: www.gazette.gov.mv

- For publication of regulations and guidelines in the Gazette, send to legallaffairs@po.gov.mv
-



**Maldives Civil Aviation Authority
Republic of Maldives**

Maldivian Civil Aviation Regulations

MCAR-M Continuing Airworthiness

Issue 5.00, 15 January 2025

Foreword

Maldives Civil Aviation Authority, in exercise of the powers conferred on it under Articles 5 and 6 of the Maldives Civil Aviation Authority Act 2/2012 has adopted this Regulation.

This Regulation shall be cited as MCAR-M Continuing Airworthiness and shall come in to force on 15 January 2025.

Existing aviation requirements in the field of airworthiness as listed in MCAR-M Continuing Airworthiness Requirements dated 30 March 2022 will be repealed as from 15 January 2025.

Definitions of the terms and abbreviations used in this regulation, unless the context requires otherwise, are in MCAR-1 Definitions and Abbreviations.

'Acceptable Means of Compliance' (AMC) illustrate a means, or several alternative means, but not necessarily the only possible means by which a requirement can be met.

'Guidance Material' (GM) helps to illustrate the meaning of a requirement.

List of Amendments

Rev #	Date	Remarks
Issue 1 Amendment 0	2007-07-15	Initial issue
Issue 1 Amendment 1	2008-08-19	
Issue 1 Amendment 2	2008-09-22	
Issue 1 Amendment 3	2009-01-06	Incorporated up to EU No. 1056/2008 and EDD 2008/013/R
Issue 1 Amendment 4	2009-05-25	Incorporated EDD 2009/006/R
Issue 2 Amendment 0	2015-10-22	Incorporated up to SARI Part M Initial Issue, EU No. 593/2012 and EDD 2013/034/R
Issue 3 Amendment 0	2019-12-18	Incorporated up to SARI Part M Issue 2, EU No. 2015/1536 and EDD 2016/011/R
Issue 4.00	2022-03-30	Incorporated up to SARI Part M Issue 2, EU No. 2020/1159 and EDD 2020/023/R
Issue 5.00	2025-01-15	Incorporated up to EU No. 2022/410 and ED Decision 2022/017/R

List of Effective Pages

Section	Part	Page	Issue	Date
	Foreword	ii	5.00	15 January 2025
	List of Amendments	iii	5.00	15 January 2025
	List of Effective Pages	iv-v	5.00	15 January 2025
	Table of Contents	vi-ix	5.00	15 January 2025
A	Technical Requirements	1-127	5.00	15 January 2025
B	Procedures for the CAA	128-146	5.00	15 January 2025
-	Appendices to the Regulations	147-190	5.00	15 January 2025
-	Appendices to the AMC and GM	191-261	5.00	15 January 2025

Table of Contents

Foreword	ii
List of Amendments.....	iii
List of Effective Pages	iv
Table of Contents	vi
GENERAL.....	1
MCAR-M. 1 Definitions	1
SECTION A – TECHNICAL REQUIREMENTS.....	2
SUBPART A – GENERAL	3
MCAR-M.A.101 Scope	3
SUBPART B – ACCOUNTABILITY	4
MCAR-M.A.201 Responsibilities.....	4
MCAR-M.A.202 Occurrence Reporting	14
SUBPART C – CONTINUING AIRWORTHINESS.....	16
MCAR-M.A.301 Continuing airworthiness tasks.....	16
MCAR-M.A.302 Aircraft Maintenance programme	20
MCAR-M.A.303 Airworthiness directives.....	24
MCAR-M.A.304 Data for modifications and repairs.....	24
MCAR-M.A.305 Aircraft continuing airworthiness record system	24
MCAR-M.A.306 Aircraft Technical Log System.....	39
MCAR-M.A.307 Transfer of Aircraft Continuing Airworthiness Records	41
SUBPART D – MAINTENANCE STANDARDS	43
MCAR-M.A.401 Maintenance Data.....	43
MCAR-M.A.402 Performance of Maintenance.....	46
MCAR-M.A.403 Aircraft Defects.....	51
SUBPART E – COMPONENTS.....	53
MCAR-M.A.501 Classification and Installation.....	53
MCAR-M.A.502 Component Maintenance	58
MCAR-M.A.503 Life-limited Parts and time-controlled components	60
MCAR-M.A.504 Segregation of components	60
SUBPART F – MAINTENANCE ORGANISATION.....	62
MCAR-M.A.601 Scope	62
MCAR-M.A.602 Application	62
MCAR-M.A.603 Extent of approval.....	62
MCAR-M.A.604 Maintenance organisation manual.....	65
MCAR-M.A.605 Facilities	66
MCAR-M.A.606 Personnel requirements	68
MCAR-M.A.607 Certifying staff and airworthiness review staff	73
MCAR-M.A.608 Components, equipment and tools.....	75
MCAR-M.A.609 Maintenance data	76
MCAR-M.A.610 Maintenance work orders.....	76
MCAR-M.A.611 Maintenance standards	76
MCAR-M.A.612 Aircraft certificate of release to service.....	76

MCAR-M.A.613 Component certificate of release to service.....	76
MCAR-M.A.614 Maintenance and airworthiness review records	82
MCAR-M.A.615 Privileges of the organisation	83
MCAR-M.A.616 Organisational review.....	84
MCAR-M.A.617 Changes to the approved maintenance organisation	85
MCAR-M.A.618 Continued validity of approval	86
MCAR-M.A.619 Findings	86
SUBPART G — CONTINUING AIRWORTHINESS MANAGEMENT ORGANISATION.....	87
MCAR-M.A.701 Scope	87
MCAR-M.A.702 Application	87
MCAR-M.A.703 Extent of approval.....	87
MCAR-M.A.704 Continuing airworthiness management exposition.....	87
MCAR-M.A.705 Facilities	90
MCAR-M.A.706 Personnel requirements	91
MCAR-M.A.707 Airworthiness review staff	94
MCAR-M.A.708 Continuing Airworthiness Management	98
MCAR-M.A.709 Documentation	101
MCAR-M.A.710 Airworthiness review	103
MCAR-M.A.711 Privileges of the organisation	104
MCAR-M.A.712 Quality system	107
MCAR-M.A.713 Changes to the approved continuing airworthiness organisation.....	109
MCAR-M.A.714 Record-keeping.....	110
MCAR-M.A.715 Continued validity of approval	111
MCAR-M.A.716 Findings	111
SUBPART H — CERTIFICATE OF RELEASE TO SERVICE - CRS	112
MCAR-M.A.801 Aircraft certificate of release to service	112
MCAR-M.A.802 Component certificate of release to service.....	120
MCAR-M.A.803 Pilot-owner authorisation	120
SUBPART I — AIRWORTHINESS REVIEW CERTIFICATE	122
MCAR-M.A.901 Aircraft airworthiness review	122
MCAR-M.A.902 Validity of the airworthiness review certificate	130
MCAR-M.A.903 Transfer of registration within Maldives	130
MCAR-M.A.904 Airworthiness review of aircraft imported into the Maldives	131
MCAR-M.A.905 Findings	134
SECTION B – PROCEDURES FOR THE CAA	135
SUBPART A — GENERAL.....	136
MCAR-M.B.101 Scope	136
MCAR-M.B.103 Findings and enforcement measure – persons	136
SUBPART B — ACCOUNTABILITY	137
MCAR-M.B.201 Responsibilities.....	137
SUBPART C — CONTINUING AIRWORTHINESS	138
MCAR-M.B.301 Aircraft maintenance programme	138
MCAR-M.B.303 Aircraft continuing-airworthiness monitoring.....	139
MCAR-M.B.304 Revocation and suspension.....	140

MCAR-M.B.305 Aircraft technical log system.....	140
SUBPART F — MAINTENANCE ORGANISATION	141
MCAR-M.B.602 Initial Approval.....	141
MCAR-M.B.603 Issue of approval.....	141
MCAR-M.B.604 Continuing oversight	142
MCAR-M.B.605 Findings	143
MCAR-M.B.606 Changes	144
MCAR-M.B.607 Revocation, suspension and limitation of an approval.....	144
SUBPART G — CONTINUING AIRWORTHINESS MANAGEMENT ORGANISATION	145
MCAR-M.B.701 Application	145
MCAR-M.B.702 Initial approval.....	145
MCAR-M.B.703 Issue of approval.....	147
MCAR-M.B.704 Continuing oversight	149
MCAR-M.B.705 Findings	150
MCAR-M.B.706 Changes.....	150
MCAR-M.B.707 Revocation, suspension and limitation of an approval.....	151
(SUBPART H – RESERVED)	152
SUBPART I — AIRWORTHINESS REVIEW CERTIFICATE.....	153
MCAR-M.B.901 Assessment of recommendations	153
MCAR-M.B.902 Airworthiness review by the competent authority.....	153
MCAR-M.B.903 Findings	154
APPENDICES TO THE REGULATIONS	155
Appendix I Continuing Airworthiness Management Contract	156
Appendix II Authorised Release Certificate - CAA Form 1	161
Appendix III Airworthiness Review Certificate – CAA Form 15.....	171
Appendix IV - Class and Rating System for the Terms of Approval of Maintenance Organisations referred to in MCAR-M Subpart F	173
Appendix V - Maintenance Organisation Certificate referred to in MCAR-M Subpart F - CAA Form 3-MF	177
Appendix VI - Continuing Airworthiness Management Organisation Certificate referred to in MCAR-M Subpart G – CAA Form 14-MG.....	180
Appendix VII Complex Maintenance Tasks.....	183
Appendix VIII - Limited Pilot-Owner Maintenance.....	185
APPENDICES TO THE AMC AND GM	200
Appendix I to AMC M.A.302 and AMC M.B.301(b) - Content of the maintenance programme.....	201
Appendix II to AMC M.A.711(a)(3) - Sub-contracting of continuing airworthiness management tasks	212
Appendix III (Reserved).....	219
Appendix IV to AMC M.A.604 - Maintenance Organisation Manual.....	220
Appendix V to AMC M.A.704 - Continuing airworthiness management exposition.....	226
Appendix VI (Reserved).....	246
Appendix VII (Reserved)	247
Appendix VIII to AMC M.A.616 - Organisational Review	248
Appendix IX to AMC M.A.602 and AMC M.A.702 CAA Form 2	252

Appendix X CAA Form 4.....	254
Appendix XI to AMC to M.A.708(c) - Contracted Maintenance.....	255
Appendix XII to AMC M.A.706(f) Fuel Tank Safety training	261
Appendix XIII to AMC M.A.712(f) Organisational review	266

GENERAL

MCAR-M. 1

Definitions

Licensed air carrier	Undertaking carrying out commercial air transport operations other than: a. air services performed by non-power driven aircraft and/or ultralight aircraft; and/or b. local flights
Limited operation	the operations of other-than-complex motor-powered aircraft for: a. cost-shared flights by private individuals, on the condition that the direct cost is shared by all the occupants of the aircraft, pilot included and the number of persons sharing the direct costs is limited to six; b. competition flights or flying displays, on the condition that the remuneration or any valuable consideration given for such flights is limited to recovery of direct costs and a proportionate contribution to annual costs, as well as prizes of no more than a value specified by the CAA; c. introductory flights, parachute dropping, sailplane towing or aerobatic flights performed either by a training organisation approved in accordance with MCAR-Aircrew, or by an organisation created with the aim of promoting aerial sport or leisure aviation, on the condition that the aircraft is operated by the organisation on the basis of ownership or dry lease, that the flight does not generate profits distributed outside of the organisation, and that whenever non-members of the organisation are involved, such flights represent only a marginal activity of the organisation;
local flight	a flight not involving carriage of passengers, mail and/or cargo between different airports or other authorised landing points;

Section A – TECHNICAL REQUIREMENTS

Subpart A — GENERAL

MCAR-M.A.101 Scope

This Section establishes the measures to be taken to ensure that the airworthiness of aircraft is maintained, including its maintenance. It also specifies the conditions to be met by the persons or organisations involved in such activities.

Subpart B — ACCOUNTABILITY

MCAR-M.A.201 Responsibilities

- (a) The owner is responsible for the continuing airworthiness of an aircraft and shall ensure that no flight takes place unless all of the following requirements are met :
- (1) the aircraft is maintained in an airworthy condition;
 - (2) any operational and emergency equipment fitted is correctly installed and serviceable or clearly identified as unserviceable;
 - (3) the airworthiness certificate remains valid;
 - (4) the maintenance of the aircraft is performed in accordance with the AMP specified in M.A.302.
- (b) When the aircraft is leased, the responsibilities of the owner are transferred to the lessee if:
1. the lessee is stipulated on the registration document, or;
 2. detailed in the leasing contract.

When reference is made in this MCAR to the 'owner', the term owner covers the owner or the lessee, as applicable.

- (c) Any person or organisation performing maintenance shall be responsible for the tasks performed.
- (d) The pilot-in-command or, in the case of licenced air carriers, the operator shall be responsible for the satisfactory accomplishment of the pre-flight inspection. That inspection shall be carried out by the pilot or another qualified person and shall not need to be carried out by an approved maintenance organisation or by certifying staff.
- (e) In the case of aircraft used by licenced air carriers, the operator shall be responsible for the continuing airworthiness of the aircraft it operates and shall:
- (1) Ensure that no flight takes place unless the conditions set out in in point (a) are met;
 - (2) take the necessary steps to ensure its approval as a continuing airworthiness management organisation ('CAMO') pursuant to MCAR-CAMO or Subpart G of this Regulation, as part of air operator certificate for the aircraft it operates;
 - (3) take the necessary steps to ensure its approval in accordance MCAR-145 or conclude a written contract in accordance with MCAR-CAMO.A.315(c) or M.A.708(c) of this Regulation with an organisation which has been approved in accordance with MCAR-145.
- (ea) By derogation to point (e)(2), at least two operators forming part of a single air carrier business grouping may use the same CAMO to assume the responsibility for the continuing airworthiness management of all the aircraft they operate, provided that all of the following requirements are met:
- (1) the CAMO is approved in accordance with MCAR-CAMO for the aircraft to be managed;

- (2) the CAMO forms part of the same air carrier business grouping as the operators concerned;
 - (3) a contract is established in accordance with Appendix I to MCAR-M between the CAMO and the AOC holder not itself approved as a CAMO;
 - (4) the CAMO has its principal place of business in the territory of Maldives;
 - (5) the individual management systems of the organisations concluding a contract are harmonised with each other.
- (eb) By derogation to point (e)(2), when the termination or revocation of an air operator certificate results in a situation where a licensed air carrier forming part of an air carrier business grouping is no longer in compliance with point M.A.201(ea), that licensed air carrier shall define and implement an action plan to the satisfaction of the CAA to comply with point M.A.201(e)(2) as soon as practicable.
- (f) For complex motor-powered aircraft, used for commercial specialised operations, for CAT operations other than those performed by licenced air carriers, or by commercial ATOs and Declared Training Organisation (DTO), the operator shall ensure that:
- (1) No flight takes place unless the conditions set out in point (a) are met;
 - (2) The tasks associated with continuing airworthiness are performed by a CAMO approved in accordance with MCAR-CAMO or Subpart G of this Regulation; when the operator is not a CAMO approved in accordance with MCAR-CAMO or Subpart G of this Regulation, it shall conclude a written contract as regards the performance of those tasks in accordance with Appendix I with an organisation approved in accordance with MCAR-CAMO or Subpart G of this Regulation;
 - (3) The CAMO referred to in (2) is approved in accordance with MCAR-145 as an organisation to qualify for the issue of an approval for the maintenance of the aircraft and of components for installation thereon, or that CAMO has concluded a written contract in accordance with MCAR-CAMO.A.315(c) or point M.A.708(c) of this Regulation with organisations approved in accordance with MCAR-145.
- (g) For complex motor powered aircraft not included in points (e) and point (f), the owner shall ensure that:
- (1) no flight takes place unless the conditions defined in point (a) are met;
 - (2) the tasks associated with continuing airworthiness are performed by a CAMO approved in accordance MCAR-CAMO or Subpart G of this Regulation; when the owner is not a CAMO approved in accordance with MCAR-CAMO or Subpart G of this Regulation, it shall conclude a written contract as regards the performance of those tasks in accordance with Appendix I with an organisation approved in accordance with MCAR-CAMO or Subpart G of this Regulation;
 - (3) the CAMO referred to in (2) is approved in accordance with MCAR-145 as an organisation to qualify for the issue of an approval for the maintenance of the aircraft and of components installation thereon, or that CAMO has concluded a written contract in accordance with point MCAR-CAMO.A.315(c) or point M.A.708(c) of this Regulation with organisations approved in accordance with MCAR-145.

- (h) For aircraft other than complex motor-powered aircraft, used for commercial specialised operations, or for CAT operations other than those performed by licenced air carriers, or commercial ATOs and commercial DTOs, the operator shall ensure that:
- (1) no flight takes place unless the conditions set out in point (a) are met;
 - (2) the tasks associated with continuing airworthiness are performed by a CAMO approved in accordance with MCAR-CAMO or Subpart G of this Regulation, or a combined airworthiness organisation ('CAO') approved in accordance with MCAR-CAO; when the operator is not a CAMO approved in accordance with MCAR-CAMO or Subpart G of this Regulation, or a CAO approved in accordance with MCAR-CAO, it shall conclude a written contract in accordance with Appendix I with a CAMO approved in accordance with MCAR-CAMO or Subpart G of this Regulation, or a CAO approved in accordance with MCAR-CAO;
 - (3) the CAMO or CAO referred in point (2) is approved in accordance with MCAR-145 or in accordance with Subpart F of this Regulation or as a CAO with maintenance privileges, or that CAMO or CAO has concluded a written contract with organisations approved in accordance with MCAR-145 or in accordance with Subpart F of this Regulation or MCAR-CAO with maintenance privileges.
- (i) For aircraft other than complex motor-powered aircraft not included in points (e) and (h), or used for limited operations, the owner shall ensure that flight takes place only if the conditions set out in point (a) are met. To that end, the owner shall:
- (1) attribute the continuing airworthiness tasks referred to in point M.A.301 to a CAMO or CAO through a written contract concluded in accordance with Appendix I; or
 - (2) carry out those tasks himself; or
 - (3) carry out those tasks himself except the tasks of the development of and the processing of the approval of the AMP, only if those tasks are performed by a CAMO or CAO through a limited contract concluded in accordance with point M.A.302.
- (j) The owner/operator shall ensure that any person authorised by the CAA is granted access to any of its facilities, aircraft or documents related to its activities, including any subcontracted activities, to determine compliance with this Regulation.
- (k) Where an aircraft included in an air operator certificate is used for non-commercial operations or specialised operations under point ORO.GEN.310 or point NCO.GEN.104 of MCAR-Air Operations, the operator shall ensure that the tasks associated with continuing airworthiness are performed by the CAMO approved in accordance with MCAR-CAMO or Subpart G of this Regulation or the combined airworthiness organisation ("CAO") approved in accordance with MCAR-CAO, whichever applicable, of the air operator certificate holder.

GM M.A.201 Responsibilities

Quick summary table

Select your type of operation and your category of aircraft			Complex motor-powered aircraft		Other-than-complex motor-powered aircraft (aircraft subject to MCAR- ML are excluded here)	
			Is a CAMO or CAO required for the management of continuing airworthiness?	Is maintenance by a maintenance organisation required?	Is a CAMO or CAO required for the management of continuing airworthiness?	Is maintenance by a maintenance organisation required?
Commercial operations	CAT	Licensed air carriers	Yes, a CAMO is required. It shall be part of the AOC (M.A.201(e)) unless point M.A.201(ea) applies.	Yes, maintenance by a MCAR-145 organisation is required (M.A.201(e))	Yes, a CAMO is required. It shall be part of the AOC (M.A.201(e)) unless point M.A.201(ea) applies.	Yes, maintenance by a MCAR-145 organisation is required (M.A.201(e))
		CAT other than licensed air carriers	Yes, a CAMO is required (M.A.201(f))	Yes, maintenance by a MCAR-145 organisation is required (M.A.201(f))	Yes, a CAMO or CAO is required (M.A.201(h))	Yes, maintenance by a Subpart F, by a MCAR-CAO or by a MCAR-145 organisation is required (M.A.201(h))
	Commercial operations other than CAT	Commercial specialised operations	Yes, a CAMO is required (M.A.201(f))	Yes, maintenance by a MCAR-145 organisation is required (M.A.201(f))	Yes, a CAMO or CAO is required (M.A.201(h))	Yes, maintenance by a Subpart F, by a MCAR-CAO or by a MCAR-145 organisation is required (M.A.201(h))
		Commercial training organisations (ATOs)	Yes, a CAMO is required (M.A.201(f))	Yes, maintenance by a MCAR-145 organisation is required (M.A.201(f))	Yes, a CAMO or CAO is required (M.A.201(h))	Yes, maintenance by a Subpart F, by a MCAR-CAO or by a MCAR-145 organisation is required (M.A.201(h))
Other than commercial operations including limited operations			Yes, a CAMO is required (M.A.201(g))	Yes, maintenance by a MCAR-145 organisation is required (M.A.201(g))	No, a CAMO or CAO is not required (M.A.201(i))	No, maintenance by a Subpart F, by a MCAR-CAO or MCAR-145 organisation is not always required (M.A.201(i))

GM M.A.201(e) Responsibilities

The performance of ground de-icing and anti-icing activities does not require a MCAR-145 maintenance organisation approval. Nevertheless, inspections required to detect and, when necessary, remove de-icing and/or anti-icing fluid residues are considered maintenance. Such inspections may only be carried out by suitably authorised personnel.

AMC M.A.201(e) (2) Responsibilities

1. A licenced air carriers only needs to hold a CAMO approval as part of its air operator certificate (AOC) for the management of the continuing airworthiness of the aircraft listed on its AOC. The approval to carry out airworthiness reviews is optional.
2. MCAR-M does not provide for CAMOs to be independently approved to perform continuing airworthiness management tasks on behalf of licenced air carriers. The approval of such activity is vested in the AOC.
3. The operator is ultimately responsible and, therefore, accountable for the airworthiness of its aircraft.

AMC1 M.A.201 (ea) Responsibilities

HARMONISATION OF THE MANAGEMENT SYSTEMS

- (a) The harmonised management systems of the organisations that conclude a contract should encompass safety by including the following elements:
 - (1) A forum to share the results and conclusions of the safety review boards (SRBs) of each organisation, which should be attended by the accountable managers, safety managers, and any other relevant nominated person(s). That forum may for example take the form of regular joint meetings of the organisations' SRBs.
 - (2) Regular exchange between the organisations of the results and conclusions of the compliance monitoring function as well as of the results of the oversight of each organisation by the CAA. The exchange of information on compliance monitoring and oversight provides for awareness, analysis, and hazard identification.
 - (3) A common or consistent safety policy and its related safety objectives.

Note: establishing common or consistent safety objectives does not prevent the organisation(s) from defining additional and/or specific safety objectives to adapt to the local environment/specificities/operations and/or to the organisation safety performance, as applicable.

- (4) Common or consistent safety management key processes (see AMC1 CAMO.A.200(a)(3) 'Management system') that are established by the CAMO and its contracting operators unless those processes relate to activities or procedures that are specific to one of those organisations (e.g. fatigue risk management system (FRMS)).
- (5) A cooperation mechanism to ensure prompt reaction when one of the organisations shares some serious concerns with another organisation.

- (6) A cooperation mechanism to ensure proper actions are coordinated at group level if there are findings at one organisation, which affect the harmonisation of the management systems.
 - (7) A cooperation mechanism with the operator(s) to manage the changes in the harmonised elements of the management systems in such a way that those changes produce their effect at the same time.
- (b) The CAMO/operator(s)' procedures should describe how the interface and harmonisation between the management systems are achieved, and specify the records to be retained in respect of the harmonisation of the management systems.

AMC2 M.A.201(ea) Responsibilities

To ensure that all parties involved can fulfil their responsibilities, all manuals, procedures, and communication between them should be in English.

GM1 M.A.201(ea) Responsibilities

HARMONISATION OF THE MANAGEMENT SYSTEMS – GROUP STANDARDS AND CHANGES THERETO

- (a) Depending on the size of the single air carrier business grouping and on the nature and complexity of its activities, an efficient way of harmonising the management systems of the organisations is by collectively developing group standards that are endorsed by a group management board or similar group governance body. Such group standards may include provisions for the monitoring of the obligations of the parties that have signed the contract established in accordance with MCAR-M.
- (b) The group management board or similar group governance body is composed of the accountable managers of the organisations and a coordinating member. The names of the board members are included directly, or by reference to a common document, in the contract, and are updated in the respective document in case of change in personnel.
- (c) The coordinating member may be one of the accountable managers or another person. As a consequence of applying point M.A.201(ea) is that several operators will use the same CAMO, the group management board may consider having as coordinating member one employee of that CAMO. The role of the coordinating member includes, but is not limited to the following:
 - ensuring that all perspectives are considered;
 - defining the by-laws of the board and ensuring they are complied with;
 - coordinating decision-making;
 - ensuring that the documentation is updated;
 - ensuring the review of the group standards;
 - ensuring the regular exchange of communication and that meetings take place; and
 - coordinating the integration of an organisation into, or, if applicable, its departure from, the business grouping.

- (d) The group standards can be documented either:
- in a common document that is cross-referenced in the continuing airworthiness management contract that is required by point M.A.201(ea); or
 - in the exposition/manual of each organisation, in which case the continuing airworthiness management contract that is required by point M.A.201(ea) should cross-reference the relevant part of the organisations' expositions/manuals; or
 - in the continuing airworthiness management contract that is required by point M.A.201(ea).
- (e) In particular, the group standards include:
- methods and procedures to address the safety management key processes;
 - identification of the different operators and the CAMO;
 - identification and contact details of the members of the group management board or of the similar group governance body; and
 - management of the changes that affect the group standards, e.g. consultation process.

GM2 M.A.201(ea) Responsibilities

AIR CARRIER BUSINESS GROUPING

- (a) In the framework of MCAR-A, 'a single air carrier business grouping' means a controlling undertaking and its controlled undertakings. All those undertakings are located in the territory of Maldives.

The controlling undertaking exercises directly or indirectly a dominant influence over the controlled undertaking by virtue of ownership, financial participation, right to appoint management or a supervisory body, the rules that govern it, or other.

The controlled and controlling undertakings include licensed air carriers as well as one or more organisations that are approved in accordance with MCAR-CAMO.

- (b) Each approved organisation is responsible for its management system, even if they follow common group standards, policies, or procedures. The accountability of each approved organisation, as defined by the relevant regulation, is not affected by being part of a single air carrier business grouping. The air carrier remains ultimately responsible for the continuing airworthiness of the aircraft it operates even if the operator decides to contract the continuing airworthiness management to a CAMO. In that case, the operator is no longer responsible for performing the continuing airworthiness tasks, as that responsibility is transferred to the contracted CAMO. The operator keeps the responsibility to fulfil the requirements in the regulations, e.g. to assess the CAMO to ensure that it has the capability and capacity to comply with the contract (see MCAR-M, Appendix I, point 7).

GM3 M.A.201(ea) Responsibilities

CONFIGURATIONS

- (a) Each AOC holder of a single air carrier business grouping may choose either to remain an approved CAMO itself (in accordance with point M.A.201(e)(2)) or to contract a CAMO (in accordance with point M.A.201(ea)).
- (b) The following schemes illustrate possible examples of configurations:

Air carriers business grouping

	<p>Each AOC holder has a contract with the CAMO in accordance with point M.A.201(ea).</p>
	<p>AOC 1, AOC 2, and AOC 3 holders have a contract with CAMO 4 each (in accordance with point M.A.201(ea)); CAMO 4 is integrated into AOC 4 (in accordance with point M.A.201(e)(2)).</p>
	<p>AOC 1, AOC 2, and AOC 3 have a contract with a CAMO each (in accordance with point M.A.201(ea)); CAMO 4 is integrated into AOC 4 (in accordance with point M.A.201(e)(2)).</p>
	<p>AOC 1 has a contract with CAMO 2 (in accordance with point M.A.201(ea)), AOC 3 has a contract with CAMO 4 (in accordance with point M.A.201(ea)), while CAMO 2 and CAMO 4 remain respectively integrated into AOC 2 and AOC 4 (in accordance with point M.A.201(e)(2)).</p>

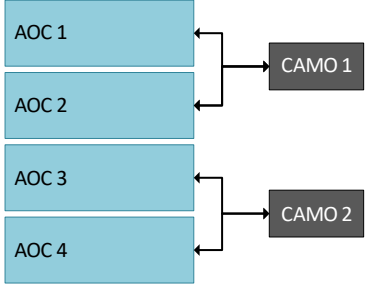
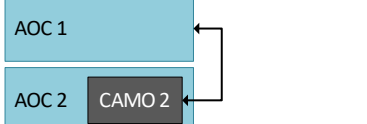
	<p>AOC 1 and AOC 2 have a contract with CAMO 1 each (in accordance with point M.A.201(ea)); AOC3 and AOC4 have a contract with CAMO 2 each (in accordance with point M.A.201(ea)).</p>
	<p>AOC 1 has a contract with CAMO 2 (in accordance with point M.A.201(ea)); CAMO 2 remains integrated into AOC 2 (in accordance with point M.A.201(e)(2)).</p>

(c) The following schemes illustrate examples of configurations that are not compliant with point M.A.201(ea) (non-exhaustive list):

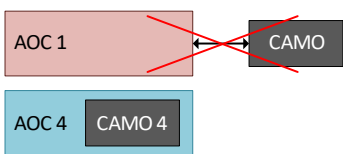
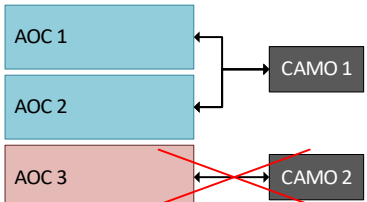
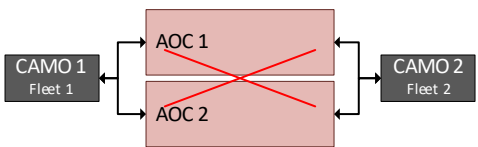
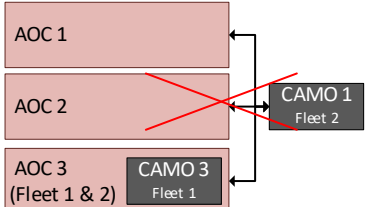
	<p>This configuration is not compliant with point M.A.201(ea) because only one AOC (i.e. AOC 1) uses the contracted CAMO.</p>
	<p>This configuration is not compliant with point M.A.201(ea) because only one AOC (i.e. AOC 3) uses the contracted CAMO (i.e. CAMO 2).</p>
	<p>This configuration is not compliant with point M.A.201(ea) because CAMO 1 is not contracted by the AOC holders (i.e. AOC 1 and AOC 2) for all the aircraft they operate.</p>
	<p>This configuration is not compliant with point M.A.201(ea) because CAMO 1 is not contracted by AOC 3 for all the aircraft it operates.</p>

GM M.A.201(i) Aircraft maintenance programme

If an owner decides not to make a contract in accordance with M.A.201(i), the owner is fully responsible for the proper accomplishment of the corresponding tasks. As a consequence, it is recommended that the owner properly self-assesses his/her own competence to accomplish them or otherwise seeks the proper expertise.

AMC M.A.201(i)(3) Responsibilities

LIMITED CONTRACT FOR THE DEVELOPMENT OF THE AMP

The limited contract for the development and, when applicable, processing of the approval of the aircraft maintenance programme should cover the responsibilities related to M.A.302(d), M.A.302(f) and M.A.302(h).

GM1 M.A.201(k) Responsibilities

USE OF AIRCRAFT INCLUDED IN AN AOC FOR NCO OR SPO

As point (k) is not a derogation from the previous points of M.A.201, points M.A.201(f), (g), (h) and (i) are still applicable.

MCAR-M.A.202 Occurrence Reporting

- (a) Without prejudice to the reporting requirements set out in MCAR-145 and MCAR-CAMO, any person or organisation responsible in accordance with point M.A.201 shall report any identified condition of an aircraft or component which endangers flight safety to:
- (1) the CAA;
 - (2) to the organisation responsible for the type design or supplemental type design.
- (b) The reports referred to in point (a) shall be made in a manner determined by the CAA and shall contain all pertinent information about the condition known to the person or organisation making the report.
- (c) Where the maintenance or the airworthiness review of the aircraft is carried out on the basis of a written contract, the person or the organisation responsible for those activities shall also report any condition referred to in point (a) to the owner and the operator of the aircraft and, when different, to the CAMO or CAO concerned.
- (d) The person or organisation shall submit the reports referred to in points (a) and (c) as soon as possible, but no later than 72 hours from the moment when the person or organisation identified the condition to which the report relates, unless exceptional circumstances prevent this.
- (e) The person or organisation shall submit a follow-up report, providing details of actions which that person or organisation intends to take to prevent similar occurrences in the future, as soon as those actions have been identified. The follow-up report shall be submitted in a form and manner established by the CAA.

AMC M.A.202(a) Occurrence Reporting

Accountable persons or organisations should ensure that the type certificate (TC) holder receives adequate reports of occurrences for that aircraft type, to enable it to issue appropriate service instructions and recommendations to all owners or operators.

Liaison with the TC holder is recommended to establish whether published or proposed service information will resolve the problem or to obtain a solution to a particular problem.

An approved continuing airworthiness management or maintenance organisation should assign responsibility for co-ordinating action on airworthiness occurrences and for initiating any necessary further investigation and follow-up activity to a suitably qualified person with clearly defined authority and status.

In respect of maintenance, reporting a condition which endangers flight safety is normally limited to:

- serious cracks, permanent deformation, burning or serious corrosion of structure found during scheduled maintenance of the aircraft or component.
- failure of any emergency system during scheduled testing.

AMC M.A.202(b) Occurrence Reporting

The reports may be transmitted by any method, i.e. electronically, by post or by facsimile.

Each report should contain at least the following information:

- reporter or organisation's name and approval reference if applicable,
- information necessary to identify the subject aircraft and/or component,
- date and time relative to any life or overhaul limitation in terms of flying hours/cycles/landings etc., as appropriate,
- details of the occurrence.

MCAR-13B provides further guidance on occurrence reporting.

Subpart C — CONTINUING AIRWORTHINESS

MCAR-M.A.301 Continuing airworthiness tasks

The aircraft continuing airworthiness and the serviceability of operational and emergency equipment shall be ensured by:

- (a) the accomplishment of pre-flight inspections;
- (b) the rectification of any defect and damage affecting safe operation in accordance with data specified in points M.A.304 and M.A.401, as applicable, while taking into account, the minimum equipment list and configuration deviation list, when they exist ;
- (c) the accomplishment of all maintenance, in accordance with the AMP referred to in point M.A.302;
- (d) the release of all maintenance in accordance with Subpart H;
- (e) for all complex motor-powered aircraft or aircraft used by licenced air carriers, the analysis of the effectiveness of the approved AMP referred to in point M.A.302;
- (f) the accomplishment of any applicable:
 - (1) airworthiness directive (AD),
 - (2) operational directive with a continuing airworthiness impact,
 - (3) continuing airworthiness requirement established by the CAA and the State of Design,
 - (4) measures required by the CAA in immediate reaction to a safety problem;
- (g) the accomplishment of modifications and repairs in accordance with M.A.304;
- (h) delivering to the pilot-in-command, or to the operator in the case of licensed air carriers, the mass and balance statement reflecting the current configuration of the aircraft;
- (i) maintenance check flights when necessary.

AMC M.A.301 (a) Continuing airworthiness tasks

PRE-FLIGHT INSPECTIONS

1. With regard to the pre-flight inspection it is intended to mean all of the actions necessary to ensure that the aircraft is fit to make the intended flight. These should typically include but are not necessarily limited to:
 - (a) a walk-around type inspection of the aircraft and its emergency equipment for condition including, in particular, any obvious signs of wear, damage or leakage. In addition, the presence of all required equipment including emergency equipment should be established.
 - (b) an inspection of the aircraft continuing airworthiness record system or the operators technical log as applicable to ensure that the intended flight is not adversely affected by any outstanding deferred defects and that no required maintenance action shown in the maintenance statement is overdue or will become due during the flight.
 - (c) a control that consumable fluids, gases etc. uplifted prior to flight are of the correct specification, free from contamination, and correctly recorded.
 - (d) a control that all doors are securely fastened.
 - (e) a control that control surface and landing gear locks, pitot/static covers, restraint devices and engine/aperture blanks have been removed.
 - (f) a control that all the aircraft's external surfaces and engines are free from ice, snow, sand, dust etc. and an assessment to confirm that, as the result of meteorological conditions and de-icing/anti-icing fluids having been previously applied on it, there are no fluid residues that could endanger flight safety. Alternatively to this pre-flight assessment, when the type of aircraft and nature of operations allow for it, the build-up of residues may be controlled through scheduled maintenance inspections/cleanings identified in the approved maintenance programme.
2. Tasks such as oil and hydraulic fluid uplift and tyre inflation may be considered as part of the pre-flight inspection. The related pre-flight inspection instructions should address the procedures to determine where the necessary uplift or inflation results from an abnormal consumption and possibly requires additional maintenance action by the approved maintenance organisation or certifying staff as appropriate.
3. In the case of licenced air carriers, the CAMO should publish guidance to maintenance and flight personnel and any other personnel performing pre-flight inspection tasks, as appropriate, defining responsibilities for these actions and, where tasks are contracted to other organisations, how their accomplishment is subject to the quality system of M.A.712 or the management system required by MCAR-CAMO.A.200. It should be demonstrated to the CAA that pre-flight inspection personnel have received appropriate training for the relevant pre-flight inspection tasks. The training standard for personnel performing the pre-flight inspection should be described in the continuing airworthiness management exposition.

AMC M.A.301(b) Continuing airworthiness tasks

1. The operator should have a system to ensure that all defects affecting the safe operation of the aircraft are rectified within the limits prescribed by the approved minimum equipment list (MEL), configuration deviation list (CDL) or maintenance data, as appropriate. Also that such defect rectification cannot be postponed unless agreed by the operator and in accordance with a procedure approved by the CAA.
2. When differing or carrying forward a defect rectification, the cumulative effect of a number of deferred or carried forward defects on a given aircraft and any restrictions contained in the MEL should be considered. Whenever possible, deferred defect rectification should be made known to the pilot/flight crew prior to their arrival at the aircraft.
3. In the case of aircraft used by licenced air carriers and of complex motor-powered aircraft, a system of assessment should be in operation to support the continuing airworthiness of an aircraft and to provide a continuous analysis of the effectiveness of the CAMO defect control system in use.

The system should provide for:

- (a) significant incidents and defects: monitor incidents and defects that have occurred in flight and defects found during maintenance and overhaul, highlighting any that appear significant in their own right.
- (b) repetitive incidents and defects: monitor on a continuous basis defects occurring in flight and defects found during maintenance and overhaul, highlighting any that are repetitive.
- (c) deferred and carried forward defects: Monitor on a continuous basis deferred and carried forward defects. Deferred defects are defined as those defects reported in operational service which are deferred for later rectification. Carried forward defects are defined as those defects arising during maintenance which are carried forward for rectification at a later maintenance input.
- (d) unscheduled removals and system performance: analyse unscheduled component removals and the performance of aircraft systems for use as part of the maintenance programme efficiency.

AMC M.A.301(c) Continuing airworthiness tasks

MAINTENANCE IN ACCORDANCE WITH THE AMP

The owner, CAO or CAMO, as applicable, should have a system to ensure that all aircraft maintenance checks are performed within the limits prescribed by the approved aircraft maintenance programme and that, whenever a maintenance check cannot be performed within the required time limit, its postponement is allowed in accordance with a procedure agreed by the CAA.

AMC M.A.301(e) Continuing airworthiness tasks

The CAMO managing the continuing airworthiness of the aircraft should have a system to analyse the effectiveness of the maintenance programme, with regard to spares, established defects, malfunctions and damage, and to amend the maintenance programme accordingly.

AMC M.A.301(f) Continuing airworthiness tasks
OPERATIONAL DIRECTIVES

Operational directives with a continuing airworthiness impact include operating rules such as extended twin-engine operations (ETOPS)/long range operations (LROPS), reduced vertical separation minima (RVSM), MNPS, all weather operations (AWOPS), RNAV, etc.

Any other continuing airworthiness requirement established by the CAA includes TC related requirements such as: certification maintenance requirements (CMR), life limited parts, airworthiness limitations contained in EASA CS-25 Book 1, Appendix H, paragraph H25.4, fuel tank system airworthiness limitations including Critical Design Configuration Control Limitations (CDCCL) etc.

The operator is responsible for the incorporation of operational directives (ODs) and in cases where there is an impact on the continuing airworthiness, the CAMO has to assess this and take appropriate actions to ensure the continuing airworthiness. The process to incorporate the ODs should be detailed in an arrangement or common procedure.

GM M.A.301(i) Continuing airworthiness tasks
MAINTENANCE CHECK FLIGHTS (MCFs)

- (a) The definition of and operational requirements for MCFs are laid down in the MCAR-Air Operations and are carried out under the control and responsibility of the aircraft operator. During the flight preparation, the flight and the post-flight activities as well as for the aircraft handover, the processes requiring the involvement of the maintenance organisations or their personnel should be agreed in advance with the operator. The operator should consult as necessary with the CAMO in charge of the airworthiness of the aircraft.
- (b) Depending on the aircraft defect and the status of the maintenance activity performed before the flight, different scenarios are possible and are described below:
 - (1) The aircraft maintenance manual (AMM), or any other maintenance data issued by the design approval holder, requires that an MCF be performed before completion of the maintenance ordered. In this scenario, a certificate after incomplete maintenance, when in compliance with MCAR-M.A.801(f) or MCAR-145.A.50(e), should be issued by the maintenance organisation and the aircraft can be flown for this purpose under its airworthiness certificate. Due to incomplete maintenance, for aircraft used in commercial air transport, it is advisable to open a new entry on the aircraft technical log system to identify the need for an MCF. This new entry should contain or refer to, as necessary, data relevant to perform the MCF, such as aircraft limitations and any potential effect on operational and emergency equipment due to incomplete maintenance, maintenance data reference and maintenance actions to be performed after the flight. After a successful MCF, the maintenance records should be completed, the remaining maintenance actions finalised and the aircraft released to service in accordance with the maintenance organisation's approved procedures.
 - (2) Based on its own experience and for reliability considerations and/or quality assurance, an operator or CAMO may wish to perform an MCF after the aircraft has undergone certain maintenance while maintenance data does not call for such a flight. Therefore, after the maintenance has been properly carried out, a certificate of release to service is issued and the aircraft airworthiness certificate remains valid for this flight.
 - (3) After troubleshooting of a system on the ground, an MCF is proposed by the maintenance

organisation as confirmation that the solution applied has restored the normal system operation. During the maintenance performed, the maintenance instructions are followed for the complete restoration of the system and therefore a certificate of release to service is issued before the flight. The airworthiness certificate is valid for the flight. An open entry requesting this flight may be recorded in the aircraft technical log.

- (4) An aircraft system has been found to fail, the dispatch of the aircraft is not possible in accordance with the maintenance data, and the satisfactory diagnosis of the cause of the fault can only be made in flight. The process for this troubleshooting is not described in the maintenance data and therefore scenario (1) does not apply. Since the aircraft cannot fly under its airworthiness certificate because it has not been released to service after maintenance, a permit to fly issued in accordance with MCAR-21 is required. After the flight and the corresponding maintenance work, the aircraft can be released to service and continue to operate under its original certificate of airworthiness.
- (c) For certain MCFs the data obtained or verified in flight will be necessary for assessment or consideration after the flight by the maintenance organisation prior to issuing the maintenance release. For this purpose, when the personnel of the maintenance organisation cannot perform these functions in flight, the maintenance organisation may rely on the crew performing the flight to complete this data or to make statements about in-flight verifications. In this case, the maintenance organisation should appoint the crew personnel to play such a role on their behalf and, before the flight, brief appointed crew personnel on the scope, functions and the detailed process to be followed, including required reporting information after the flight and reporting means, in support of the final release to service to be issued by the certifying staff.

MCAR-M.A.302 Aircraft Maintenance programme

- (a) Maintenance of each aircraft shall be organised in accordance with an AMP.
- (b) The AMP and any subsequent amendments thereto shall be approved by the CAA.
- (c) When the continuing airworthiness of the aircraft is managed by a CAMO or CAO or when there is a limited contract between the owner and a CAMO or CAO concluded in accordance with point M.A.201(i)(3), the AMP and its amendments may be approved through an indirect approval procedure.

In that case, the indirect approval procedure shall be established by the CAMO or CAO concerned as part of the Continuing Airworthiness Management Exposition ('CAME') referred to in point MCAR-CAMO.A.300 or point M.A.704 of this Regulation, or as part of the combined airworthiness exposition ('CAE') referred to in point MCAR-CAO.A.025 and shall be approved by the CAA.

- (d) The AMP shall demonstrate compliance with:
- (1) instructions issued by the CAA;
- (2) instructions for continuing airworthiness:
- (i) issued by the holders of the type certificate, restricted type-certificate, supplemental type-certificate, major repair design approval, TSO/ETSO authorisation or any other relevant approval issued or accepted under MCAR-21.

- (ii) Included in the certification specifications referred to in point 21.A.90B or 21.A.431B of MCAR-21, if applicable;
- (3) the applicable provisions of MCAR-26.
- (e) By derogation to point (d), the owner or the organisation managing the continuing airworthiness of the aircraft may deviate from the instruction referred to in point (d)(2) and propose escalated intervals in the AMP, based on data obtained from sufficient reviews carried out in accordance with point (h). Indirect approval is not permitted for the escalation of safety related tasks. The owner or the organisation managing the continuing airworthiness of the aircraft may also propose additional instructions in the AMP.
- (f) The AMP shall contain details of all maintenance to be carried out, including frequency and any specific tasks linked to the type and the specificity of operations.
- (g) For complex motor-powered aircraft, when the AMP is based on maintenance steering group logic or on condition monitoring, the AMP shall include a reliability programme.
- (h) The AMP shall be subject to periodic reviews and amended accordingly when necessary. Those reviews will ensure that the AMP continues to be up to date and valid in light of the operating experience and instructions from the competent authority whilst taking into account new or modified maintenance instructions issued by the type certificate and supplementary type certificate holders and any other organisation that publishes such data in accordance with MCAR-21.
- (i) The design and application of the operator's maintenance programme shall observe Human Factors principles.

AMC M.A.302 Aircraft Maintenance Programme

BASIC PRINCIPLES

1. The term "maintenance programme" is intended to include scheduled maintenance tasks the associated procedures and standard maintenance practises. The term "maintenance schedule" is intended to embrace the scheduled maintenance tasks alone.
2. The aircraft should only be maintained to one approved maintenance programme at a given point in time. Where an owner or operator wishes to change from one approved programme to other, a transfer check or inspection may need to be performed in order to implement the change.
3. The maintenance programme details should be reviewed at least annually. As a minimum revisions of documents affecting the programme basis need to be considered by the owner or operator for inclusion in the maintenance programme during the annual review. Applicable mandatory requirements for compliance with MCAR-21 should be incorporated into the aircraft maintenance programme as soon as possible
4. The aircraft maintenance programme should contain a preface which will define the maintenance programme contents, the inspection standards to be applied, permitted variations to task frequencies and, where applicable, any procedure to manage the evolution of established check or inspection intervals.

5. Repetitive maintenance tasks derived from modifications and repairs should be incorporated into the approved maintenance programme.
6. Appendix I to AMC M.A.302 and AMC M.B.301(b) provide detailed information on the contents of an approved aircraft maintenance programme.

GM M.A.302(a) Aircraft Maintenance Programme

A maintenance programme may indicate that it applies to several aircraft registrations as long as the maintenance programme clearly identifies the effectivity of the tasks and procedures that are not applicable to all of the listed registrations.

AMC M.A.302(d) Aircraft Maintenance Programme

AMP BASIS AND ASSOCIATED PROGRAMMES

1. An aircraft maintenance programme should normally be based upon the maintenance review board (MRB) report where applicable, the maintenance planning document (MPD), the relevant chapters of the maintenance manual or any other maintenance data containing information on scheduling. Furthermore, an aircraft maintenance programme should also take into account any maintenance data containing information on scheduling for components.
2. Instructions issued by the competent authority can encompass all types of instructions from a specific task for a particular aircraft to complete recommended maintenance schedules for certain aircraft types that can be used by the owner/operator directly. These instructions may be issued by the competent authority in the following cases:
 - in the absence of specific recommendations of the Type Certificate Holder.
 - to provide alternate instructions to those described in the subparagraph 1 above, with the objective of providing flexibility to the operator.
3. Where an aircraft type has been subjected to the MRB report process, an operator should normally develop the initial aircraft maintenance programme based upon the MRB report.
4. Where an aircraft is maintained in accordance with an aircraft maintenance programme based upon the MRB report process, any associated programme for the continuous surveillance of the reliability, or health monitoring of the aircraft should be considered as part of the aircraft maintenance programme.
5. Aircraft maintenance programmes for aircraft types subjected to the MRB report process should contain identification cross reference to the MRB report tasks such that it is always possible to relate such tasks to the current approved aircraft maintenance programme. This does not prevent the approved aircraft maintenance programme from being developed in the light of service experience to beyond the MRB report recommendations but will show the relationship to such recommendations
6. Some approved aircraft maintenance programmes, not developed from the MRB process, utilise reliability programmes. Such reliability programmes should be considered as a part of the approved maintenance programme.

7. Alternate and/or additional instructions to those defined in paragraphs M.A.302(d)(1) and (2), proposed by the owner or the operator, may include but are not limited to the following:
 - Escalation of the interval for certain tasks based on reliability data or other supporting information. Appendix 1 to AMC M.A.302 and AMC M.B.301(b) recommends that the maintenance programme contains the corresponding escalation procedures. The escalation of these tasks is directly approved by the CAA, except in the case of ALIs (Airworthiness Limitations), which are approved by the State of Design.
 - More restrictive intervals than those proposed by the TC holder as a result of the reliability data or because of a more stringent operational environment.
 - Additional tasks at the discretion of the operator.

AMC M.A.302 (g) Aircraft Maintenance Programme
RELIABILITY PROGRAMMES

1. Reliability programmes should be developed for aircraft maintenance programmes based upon maintenance steering group (MSG) logic or those that include condition monitored components or that do not contain overhaul time periods for all significant system components.
2. Reliability programmes need not be developed for aircraft not considered complex motor-powered aircraft or that contain overhaul time periods for all significant aircraft system components.
3. The purpose of a reliability programme is to ensure that the aircraft maintenance programme tasks are effective and their periodicity is adequate.
4. The reliability programme may result in the escalation or deletion of a maintenance task, as well as the de-escalation or addition of a maintenance task.
5. A reliability programme provides an appropriate means of monitoring the effectiveness of the maintenance programme.
6. Appendix I to AMC M.A.302 and M.B.301(d) gives further guidance.

GM M.A.302 (i) Aircraft Maintenance Programme

The design of the aircraft maintenance programme has two aspects: first, the definition of actual work tasks and, second, the design and presentation of the programme document itself.

An aircraft maintenance programme design that observes human factors principles should take into account:

- task or job sequences which are likely to reduce the probability or effect of error in its application;
- work packages which suit an operator's specific operation; and
- task or job cards or sheets which meet a standard for good document design, in particular with regard to:
 - written language, which involves not only vocabulary and grammar, but also the manner in which they are used;

- the typography and the layout have a significant impact on the comprehension of the written material;
- the use of diagrams, charts or tables replacing long descriptive text is advantageous to assist comprehension; and
- the use of colour in illustrations reduces the discrimination workload and has a motivational effect.

MCAR-M.A.303 Airworthiness directives

Any applicable airworthiness directive must be carried out within the requirements of that airworthiness directive, unless otherwise specified by the CAA.

MCAR-M.A.304 Data for modifications and repairs

A person or organisation repairing an aircraft or a component, shall assess any damage. Modifications and repairs shall be carried out using, as appropriate, the following data:

- (a) data approved by the CAA; or
- (b) data approved by a design organization accepted under MCAR-21; or
- (c) data contained in the certification specifications referred to in point 21A.90B or 21A.431B of MCAR-21

AMC M.A.304 Data for modifications and repairs

A person or organisation repairing an aircraft or component should assess the damage against published approved repair data and the action to be taken if the damage is beyond the limits or outside the scope of such data. This could involve any one or more of the following options; repair by replacement of damaged parts, requesting technical support from the type certificate holder or from an organisation accepted in accordance with MCAR-21 and finally CAA approval of the particular repair data.

MCAR-M.A.305 Aircraft continuing airworthiness record system

- (a) At the completion of any maintenance, aircraft certificate of release to service (CRS) required by point M.A.801 or point MCAR-145.A.50, as applicable, shall be entered in the aircraft continuing airworthiness record system, as soon as practicable and no later than 30 days after the completion of any maintenance.
- (b) The aircraft continuing airworthiness records shall contain the following :
 - 1. the date of the entry, the total in-service life accumulated in the applicable parameter for aircraft, engine(s) and/or propeller(s);
 - 2. the aircraft continuing airworthiness records described in points (c) and (d) below together with the supporting detailed maintenance records described in point (e) below;
 - 3. if required by point M.A.306, the aircraft technical log.

- (c) The aircraft continuing airworthiness records shall include the current mass and balance report and the current status of:
1. ADs and measures mandated by the CAA in immediate reaction to a safety problem;
 2. modifications and repairs;
 3. compliance with the AMP;
 4. deferred maintenance tasks and deferred defects rectification.
- (d) The aircraft continuing airworthiness records shall include the current status specific to components of:
1. life-limited parts, including the life accumulated by each affected part in relation to the applicable airworthiness limitation parameter; and
 2. time-controlled components, including the life accumulated by the affected components in the applicable parameter, since the last accomplishment of scheduled maintenance, as specified in the AMP.
- (e) The owner or operator shall establish a system to keep the following documents and data in a form acceptable to the CAA and for the periods specified below:
1. aircraft technical log system: the technical log or other data equivalent in scope and detail, covering the 36 months period prior to the last entry,
 2. the CRS and detailed maintenance records:
 - (i) demonstrating compliance with ADs and measures mandated by the CAA in immediate reaction to a safety problem applicable to the aircraft, engine(s), propeller(s) and components fitted thereto, as appropriate, until such time as the information contained therein is superseded by new information equivalent in scope and detail but covering a period not shorter than 36 months;
 - (ii) demonstrating compliance with the applicable data in accordance with point M.A.304 for current modifications and repairs to the aircraft, engine(s), propeller(s) and any component subject to airworthiness limitations; and
 - (iii) of all scheduled maintenance or other maintenance required for continuing airworthiness of aircraft, engine(s), propeller(s), as appropriate, until such time as the information contained therein is superseded by new information equivalent in scope and detail but covering a period not shorter than 36 months.
 3. data specific to certain components:
 - (i) an in-service history record for each life-limited part based on which the current status of compliance with airworthiness limitations is determined;
 - (ii) the CRS and detailed maintenance records for the last accomplishment of any scheduled maintenance and any subsequent unscheduled maintenance of all life-

limited parts and time-controlled components until the scheduled maintenance has been superseded by another scheduled maintenance of equivalent scope and detail but covering a period not shorter than 36 months;

- (iii) the CRS and owner's acceptance statement for any component that is fitted to an ELA2 aircraft without a CAA Form 1 in accordance with point MCAR-21.A.307(b)(2) but covering a period not shorter than 36 months.

4. Record-keeping periods when the aircraft is permanently withdrawn from service:

- (i) the data required by point M.A.305(b)(1) in respect of aircraft, engine(s), and propeller(s) which shall be retained for at least 12 months;
 - (ii) the last effective status and reports as identified under points (c) and (d) of M.A.305 which shall be retained for at least 12 months; and
 - (iii) the most recent CRS(s) and detailed maintenance records as identified under points (e)(2)(ii) and (e)(3)(i) of M.A.305 which shall be retained for at least 12 months.
- (f) The person responsible for the management of continuing airworthiness tasks pursuant to point M.A.201 shall comply with the requirements regarding the aircraft continuing airworthiness record system and present the records to the CAA upon request.
- (g) All entries made in the aircraft continuing airworthiness record system shall be clear and accurate. When it is necessary to correct an entry, the correction shall be made in a manner that clearly shows the original entry.

GM M.A.305 Aircraft continuing airworthiness record system

- (a) The aircraft continuing airworthiness records are the means to assess the airworthiness status of a product and its components. An aircraft continuing airworthiness record system includes the processes to keep and manage those records and should be proportionate to the subject aircraft. Aircraft continuing airworthiness records should provide the owner/CAO/CAMO of an aircraft with the information needed:
- (1) to demonstrate that the aircraft is in compliance with the applicable airworthiness requirements; and
 - (2) to schedule all future maintenance as required by the aircraft maintenance programme based, if any, on the last accomplishment of the specific maintenance as recorded in the aircraft continuing airworthiness records.
- (b) 'Applicable airworthiness limitation parameter' and 'applicable parameter' refer to 'flight hours' and/or 'flight cycles' and/or 'landings' and/or 'calendar time', and/or any other applicable utilisation measurement unit, as appropriate.
- (c) A 'life-limited part' is a part for which the maintenance schedule of the aircraft maintenance programme requires the permanent removal from service when, or before, the specified mandatory life limitation of the applicable parameters is reached.

- (d) The 'current status' when referring to components of life-limited parts should indicate, for each affected part, the life limitation, the total life accumulated in any applicable parameter (as appropriate) and the remaining life in any applicable parameter before the life limitation is reached.
- (e) The term 'time-controlled components' embraces any component for which the maintenance schedule of the aircraft maintenance programme requires periodically the removal for maintenance to be performed in an appropriate approved organisation for maintenance in components (workshop) to return the component to a specified standard, the replacement of sub-components of the assembly by new ones, or the inspection or test of component's performance, after a service period controlled at component level in accordance with the specified airworthiness limitation defined in MCAR-21, in any of the applicable parameters.
- (f) The 'current status' when referring to time controlled components refers to the current status of compliance with the required periodic maintenance task(s) from the maintenance schedule of the aircraft maintenance programme specific to the time-controlled components. It should include the life accumulated by the affected components in the applicable parameter, as appropriate, since the last accomplishment of scheduled maintenance specified in the maintenance schedule of the aircraft maintenance programme. Any action that alters the periodicity of the maintenance task(s) or changes the parameter of this periodicity should be recorded.
- (g) 'Detailed maintenance records' in this part refers to those records required to be kept by the person or organisation responsible for the aircraft continuing airworthiness in accordance with M.A.201 in order that they may be able to fulfil their obligations under this Regulation.

These are only a part of the detailed maintenance records required to be kept by a maintenance organisation under point M.A.614, MCAR-CAO.A.090(a) or MCAR-145.A.55(a). Maintenance organisations are required to retain all detailed records to demonstrate that they worked in compliance with their respective requirements and quality procedures.

Not all records need to be transferred from the maintenance organisation to the person or organisation responsible for the aircraft continuing airworthiness in accordance with M.A.201 unless they specifically contain information relevant to aircraft configuration and future maintenance. Thus, incoming certificates of conformity, batch number references and individual task card sign-offs verified by and/or generated by the maintenance organisation are not required to be retained by the person or organisation responsible in accordance with M.A.201. However, dimensional information contained in the task card sign-off or work pack may be requested by the owner/CAO/CAMO in order to verify and demonstrate the effectiveness of the aircraft maintenance programme.

Information relevant to future maintenance may be contained in specific documents related to:

- modifications;
- airworthiness directives;
- repaired and non-repaired damage;
- components referred in M.A.305(d); and
- measurements relating to defects.

- (h) An airworthiness limitation is a boundary beyond which an aircraft or a component thereof must not be operated, unless the instruction(s) associated with this airworthiness limitation is (are) complied with.
- (i) 'Other maintenance required for continuing airworthiness' refers to unscheduled or out-of-phase maintenance due to abnormal or particular conditions or events with an impact on the continuing airworthiness of the aircraft at the time of its return to service. It is not intended to request every single condition described in the maintenance data, e.g. Aircraft Maintenance Manual Chapter 5, but just those that cannot be captured by other means; for example, when they are not included in the records for repairs. Some abnormal or particular conditions or events that could be kept under this requirement could be lightning strikes, hard landings, long-term storage, propeller or rotor over-speed, over-torque, impact on a main rotor blade, etc.
- (j) The term 'in-service history record' embraces records from which the current status of life-limited parts can be determined. The 'in-service history record' template could be adjusted to the relevant characteristics of the life-limited part, e.g. an engine disk being different from a fire extinguisher squib or landing gear sliding tube.

Such records document each time a life-limited part is placed in service or removed from service. They should clearly:

- (1) identify the part by its part number and serial number,
- (2) show the date of installation and removal (i.e. date on/date off),
- (3) show the details of the installation and removal (i.e. type, serial number, weight variant, thrust rating, as appropriate, of the aircraft, engine, engine module, or propeller) at installation and removal of the part when this is necessary to appropriately control the life limitation.
- (4) Show the total in-service life accumulated in any applicable parameter, as appropriate, corresponding to the dates of installation and removal of the part.

Any other events that would affect the life limitation, such as an embodied modification (in accordance with airworthiness directives, service bulletins or any product improvements) that affects the life limitation or changes the limitation parameter, should also be included in the in-service history record. Not all modifications would necessarily be pertinent to the life limitation of the component. Additionally, if a parameter is not relevant to the life of the part, then that parameter does not need to be recorded.

- (k) The term 'permanently withdrawn from service' refers to moving the aircraft or component to a location that is not used for storage and/or future return to service.
- (l) The term 'current status' refers to the data which accurately establishes the level of compliance of an aircraft, engine, propeller or component thereof, with a requirement. Each status should:
 - (1) identify the aircraft, the engine, the propeller or the component it applies to;
 - (2) be dated; and
 - (3) include the relevant total in-service life accumulated in the applicable parameter on the date of the status.

AMC M.A.305(a) Aircraft continuing airworthiness record system
CERTIFICATE OF RELEASE TO SERVICE

- (a) The inclusion of the certificate of release to service in the aircraft continuing airworthiness record system means that the date and/or any applicable parameter at which the maintenance was performed, including a unique reference to the certificate of release to service, should be processed in the record system.
- (b) For components with airworthiness limitations, this information should be found on the authorised release certificate (CAA Form 1 or equivalent). For life-limited parts, some relevant information required by M.A.305 may need to be introduced in the in-service history records.

AMC M.A.305(b)1 Aircraft continuing airworthiness record system
IN-SERVICE LIFE FOR ENGINES, PROPELLERS AND APU'S

- (a) Some gas turbine engines and propellers are assembled from modules and the total life accumulated in service for the complete engine or propeller may not be kept. When owners and operators wish to take advantage of the modular design, then the total life accumulated in service for each module, as well as in-service history if applicable, and detailed maintenance records for each module, should be maintained. The continuing airworthiness records as specified should be kept with the module and should show compliance with any mandatory requirements pertaining to that module.
- (b) The recording of in-service life accumulation may be necessary also in other measurement units to ensure the continuing airworthiness of the aircraft. For example, a mandatory life limitation measured in cycles of auxiliary power unit (APU) usage may apply to some rotating parts. In such a case, APU cycles need to be recorded.

AMC M.A.305(c)1 Aircraft continuing airworthiness record system
AIRWORTHINESS DIRECTIVES

- (a) The current status of ADs, and measures mandated by the CAA in immediate reaction to a safety problem, should identify the product/component, the applicable ADs including revision or amendment numbers and the date on which the status was updated. For the purpose of assessing the AD status, there is no need to list those ADs which are superseded or cancelled.
- (b) If the AD is generally applicable to the aircraft or component type but is not applicable to the particular aircraft, engine, propeller or component, then this should be identified with the reason why it is not applicable.
- (c) The current status of ADs should include the release to service date on which the AD or measure was accomplished (the date the certificate of release to service was issued), and where the AD or measure is controlled by flight hours and/or flight cycles and/or landings and/or any other applicable parameter, as appropriate, it should include the corresponding total life on that parameter accumulated in service on the date when the AD or measure was accomplished and/or the due limit in the appropriate parameter. For repetitive ADs or measures, only the last and next applications with the reference to the applicable parameter should be recorded in the current status.

- (d) The status should also specify the method of compliance and which part of a multi-part AD or measure has been accomplished, where a choice is available in the AD or measure.
- (e) The current status of AD should be sufficiently detailed to identify any loadable software aircraft part which is used for operating or controlling the aircraft.
- (f) When the AD is multi-part or requests assessments of certain inspections, this information should be shown as well.

AMC M.A.305(c)2 Aircraft continuing airworthiness record system
MODIFICATION AND REPAIRS

- (a) Status of current modifications and repairs means a list compiled at aircraft level of modifications and repairs currently embodied. It should include the identification of the aircraft, engine(s) or propeller(s), as appropriate, and the date of the certificate of release to service when the modification or repair was accomplished. Where a modification or repair creates the need for the accomplishment of scheduled maintenance tasks, the reference to the applicable tasks should be added to the aircraft maintenance programme. The status should include the reference to the data in accordance with M.A.304 that provides the accomplishment procedure for the modification or repair. It should also specify which part of a multi-part modification or repair has been accomplished and the method of compliance, where a choice is available in the data.
- (b) In addition to the previous applicable information, in respect to structure, the status of the current repairs should contain the description of the repair (e.g. doubler, blend, crack, dent, etc.), its location (e.g. reference to stringers, frames, etc.) and the dimensions. In the case of blend-out repairs, the remaining material should be recorded too.
- (c) The status of modifications should be sufficiently detailed to identify any installed loadable software aircraft part used for operating or controlling the aircraft, the part number of which evolves independently of its associated aircraft hardware component, as identified in the maintenance data of the relevant design approval holders.

Other loadable software parts, such as navigational data bases or entertainment systems, are not considered under this recording requirement.

- (d) For the purpose of this paragraph, a component replaced by a fully interchangeable alternate component is not considered a modification if this condition is published by the design approval holder.
- (e) The status of modifications and repairs should include engine(s), propeller(s) and components subject to mandatory instructions and associated airworthiness limitations, and it is not intended that it should be retained for other components.

GM M.A.305(c)(2) Aircraft Continuing Airworthiness Record System

IMPACT OF MODIFICATIONS AND REPAIRS

- (a) The status of modifications and repairs may include the impact of a specific modification or repair in:
 - (1) embodiment instructions;
 - (2) mass and balance change data;
 - (3) maintenance and repair manual supplements;
 - (4) maintenance programme changes and instructions for continuing airworthiness; and/or
 - (5) aircraft flight manual supplements.
- (b) When aircraft require a specific loadable software aircraft part configuration in order to operate correctly, a specific listing with this information may be necessary too.

AMC M.A.305(c)3 Aircraft Continuing Airworthiness Record System

AIRCRAFT MAINTENANCE PROGRAMME

- (a) The current status of compliance with the aircraft maintenance programme means the last and next accomplishment data (referring to the applicable parameter) for the tasks specified in the maintenance schedule of the aircraft maintenance programme. It should include:
 - (1) an identifier specific enough to allow an easy and accurate identification of the task to be carried out, such as a task reference combined with a task title or short description of the work to be performed;
 - (2) the engine, propeller or component identification when the task is controlled at engine, propeller, or component level; and
 - (3) the date when the task was accomplished (i.e. the date the certificate of release to service was issued) and for repetitive tasks when it is next due time, as well as when the terminating action is performed.
- (b) Where the task is controlled by flight hours and/or flight cycles and/or landings and/or calendar time and/or any other applicable parameter, the total in-service life accumulated by the aircraft, engine, propeller or component (as appropriate) in the suitable parameter(s) should also be included.

GM M.A.305(d) Aircraft Continuing Airworthiness Record System

LIFE-LIMITED PARTS AND TIME-CONTROLLED COMPONENTS

- (a) A part is to be considered a life-limited part and a time-controlled component when it complies with both definitions given in paragraphs (c) and (e) of GM M.A.305. For example, the maintenance schedule of the aircraft maintenance programme may include both a mandatory permanent removal for a landing gear sliding tube and a periodic removal for overhaul of the landing gear (including the sliding tube).

(b) The following table provides a summary of the records’ requirements related to life-limited parts and time-controlled components:

Maintenance task from the maintenance schedule of the AMP		Type of component	Continuing airworthiness records
Mandatory instructions (and associated airworthiness limitations) in accordance with MCAR-21 affecting a component	Permanent removal (replacement)	Life-limited part e.g.: engine HPT disc, landing gear sliding tube	<ul style="list-style-type: none"> - Current status (M.A.305(d)(1)); - In-service history record (M.A.305(e)(3)(i)); - CAA Form 1 and detailed maintenance records for last scheduled maintenance and subsequent unscheduled maintenance (M.A.305(e)(3)(ii)); - CAA Form 1 and detailed maintenance records for modifications and repairs (M.A.305(e)(2)(ii))
	Periodic removal for maintenance in an appropriate approved workshop, e.g.: — Overhaul of horizontal stabiliser actuator or of a landing gear — Replacement of a U-joint (of a gearbox)	Time-controlled component e.g.: horizontal stabiliser actuator, landing gear gearbox	<ul style="list-style-type: none"> - Current status (M.A.305(d)(2)); - CAA Form 1 and detailed maintenance records for last scheduled maintenance and subsequent unscheduled maintenance (M.A.305(e)(3)(ii)); and - CAA Form 1 and detailed maintenance records for modifications and repairs (M.A.305(e)(2)

GM M.A.305(d)(2) Aircraft continuing airworthiness record system

TASKS CONTROLLED AT COMPONENT LEVEL

(a) The maintenance schedule of the aircraft maintenance programme may include tasks controlled at component level coming from a mandatory requirement in accordance with MCAR- 21 and to be performed in a workshop, such as:

- (1) the removal of a component for periodic restoration to return the component to a specified standard (e.g. removal of the landing gear for overhaul);
- (2) the periodic removal of a component for replacement of a sub-component by a new one when it is not possible to restore the item to a specific standard of failure resistance (e.g. discarding of universal joints of a gearbox, batteries of the escape slide/raft, discharge cartridges of fire extinguishers, etc.); and

- (3) a periodic inspection or test to confirm that a component meets specified performance standards (e.g. functional check of the portable emergency locator transmitter, etc.). The component is left in service (no further maintenance action taken) on the condition that it continues to fulfil its intended purpose within specified performance limits until the next scheduled inspection.

The above tasks apply to 'time-controlled components' as defined in paragraph (e) of GM M.A.305. If a component affected by a task in accordance with (2) and (3) above is controlled at aircraft level by the aircraft maintenance programme and it has not been removed since the task was last accomplished, then its status of compliance with M.A.305(d)2 is already demonstrated by the aircraft records.

Note: The maintenance in accordance:

- with (1) and (2) above assumes a predictable deterioration of the component: the overall reliability invariably decreases with age; and
 - with (3) assumes a gradual deterioration of the component: failure resistance can reduce and drop below a defined level.
- (b) When a component is affected by a maintenance task contained the aircraft maintenance programme (AMP) that is recommended by the design approval holder (DAH) and controlled at component level, although such component does not qualify as a time-controlled component, the status of the component may be needed to show that all the maintenance due on the aircraft according to the aircraft maintenance programme has been carried out. There is no a specific requirement to keep the CAA Form 1 or equivalent or any other detailed maintenance records.
 - (c) For aircraft maintenance programmes developed under a primary maintenance process-oriented methodology (e.g. Maintenance Steering Group), the term 'time-controlled component' pertains to 'Hard Time' and 'On-Condition'. The primary maintenance processes are:
 - (1) Hard Time
This is a preventive process in which known deterioration of a component is limited to an acceptable level by the maintenance actions which are carried out at periods related to time in service (e.g. calendar time, number of cycles, number of landings). The prescribed actions restore the component utility margin to the applicable time limitation.
 - (2) On-Condition

It is a preventive process in which the component is inspected or tested, at specified periods, to an appropriate standard in order to determine whether it can continue in service. The purpose is to remove the component before its failure in service.
 - (3) Condition Monitoring

This is a process in which a parameter of a condition in a component (vibration, temperature, oil consumption, etc.) is monitored to identify the development of a fault. The purpose is to remove the component before its failure in service (e.g. due to related repair costs), but they are permitted to remain in service without preventive maintenance until a functional failure occurs.

Note: For components that are not subject to any of these primary maintenance processes, corrective maintenance is carried out after failure detection and is aimed at restoring components to a condition in which they can perform their intended function ('fly-to failure').

(d) The following table provides a summary of the records' requirements related to components subjected to primary maintenance process, including components without a CAA Form 1 in accordance with 21.A.307(c):

	Primary maintenance process	Continuing airworthiness records
Life-limited part		<ul style="list-style-type: none"> - Current status (M.A.305(d)(1)); - In-service history record (M.A.305(e)(3)(i)); - CAA Form 1 and detailed maintenance records for last scheduled maintenance and subsequent unscheduled maintenance (M.A.305(e)(3)(ii)), including modifications and repairs (M.A.305(e)(2)(ii)).
Time-controlled component	Hard time	<ul style="list-style-type: none"> - Current status (M.A.305(d)(2)); - CAA Form 1 and detailed maintenance records for last scheduled maintenance and subsequent unscheduled maintenance (M.A.305(e)(3)(ii)), including modifications and repairs (M.A.305(e)(2)(ii)).
	On condition	<ul style="list-style-type: none"> - Current status (M.A.305(d)(2)); and - CAA Form 1 and detailed maintenance records for last scheduled maintenance and subsequent unscheduled maintenance (M.A.305(e)(3)(ii)) <p>If the task is controlled at aircraft level, the above information could be already contained in the records related to the aircraft maintenance programme (M.A.305(c)(3) and M.A.305(e)(2)(iii)). If the maintenance was performed off wing, the CAA Form 1 needs to be kept.</p>
Condition monitoring		The CAA Form 1 does not need to be kept unless this is the means to fulfil another requirement; for example, an AD compliance.
ELA 2 aircraft : any component that is fitted without an EASA Form 1 in accordance with 21.A.307 (c)		The certificate of release to service and owner's acceptance statement (M.A.305(e)(3)(iii)).

AMC M.A.305(e) Aircraft Continuing Airworthiness Record System
 INFORMATION TECHNOLOGY (IT) SYSTEMS AND FORM OF RECORDS

(a) The information that constitutes the aircraft continuing airworthiness records may be entered in an information technology (IT) system and/or documents equivalent in scope and detail.

IT systems acceptable for supporting the aircraft continuing airworthiness records should:

- (1) include functions so that search of data and production of status is possible;
 - (2) allow a transfer of the aircraft continuing airworthiness records data from one system to another using an industry-wide/worldwide data format or allow printing information;
 - (3) contain safeguards which prevent unauthorised personnel from altering data; and
 - (4) ensure the integrity of the data, including traceability of amendments.
- (b) 'Data equivalent in scope and detail' are included in the airworthiness record system and could be an aircraft logbook, engine logbook(s) or engine module log cards, propeller logbook(s) and log cards for life-limited parts.

Any logbook/log card should contain:

- (1) identification of the product or component it refers to;
- (2) type, part number, serial number and registration, as appropriate, of the aircraft, engine, propeller, engine module, or component to which the component has been fitted in, along with the reference to the installation and removal;
- (3) the date and the corresponding total in-service life accumulated in any applicable parameter unit, as appropriate; and
- (4) any AD, modification, repair, maintenance or deferred maintenance tasks applicable.

When fulfilling the applicable requirements, a logbook/log card as described above could be a means to comply with the current status and the in-service history record for each life-limited part.

(c) Form of records

Producing and/or keeping continuing airworthiness records in a form acceptable to the CAA normally means in either material/physical or electronic state, or a combination of both.

Retention of records should be done in one of the following formats:

- (1) original paper document or electronic data (via an approved electronically signed form);
- (2) a paper reproduction of a paper document (original or copy); or
- (3) an electronic reproduction of electronic data (original or copy); or
- (4) a printed reproduction of electronic data (original or copy); or
- (5) an electronically digitised reproduction of a paper document (original or copy); or
- (6) a microfilm or scanned reproduction copy of a paper document (original or copy).

Where IT systems are used to retain documents and data, it should be possible to print a paper version of the documents and data kept.

(d) Physical (non-digitised) records

All physical records should remain legible throughout the required retention period. Physical records on either paper or microfilm systems should use robust material, which can withstand normal handling, filing and ageing. They should be stored in a safe way with regard to damage, alteration and theft.

(e) Digitised records

Digitised records may be created from a paper document (original or copy) or from electronic data.

When created from a paper document:

- (1) the creation date of the digitised record should be stored with the digitised record;
- (2) it is advisable to create an individual digitised record for each document;
- (3) if an organisation creates a large number of digitised records, the use of database technology should ease the future retrieval of the record; and
- (4) digitised records should be legible, including details such as, but not limited to, the date of signature, names, stamps, notes, or drawings.

(f) Digitised record retention

Digitised records when created from an original paper record, or as a digital electronic original, should be stored on a system which is secured and kept in an environment protected from damage (e.g. fire, flooding, excessive temperature or accidental erasing). IT systems should have at least one backup system, which should be updated at least within 24 hours of any entry in the primary system. Access to both primary and backup systems is required to be protected against the ability of unauthorised personnel to alter the database and they should preferably be located remotely from the main system.

The system used for retention of digitised records should:

- (1) ensure the integrity, accuracy and completeness of the record;
- (2) ensure that access to the digitised record has safeguards against alteration of the data;
- (3) ensure the authenticity of the record including assurance that the date has not been modified after creation;
- (4) be capable of retrieving individual records within a reasonable time period; and
- (5) be maintained against technological obsolescence which would prevent printing, displaying or retrieval of the digitised records.

Computer backup discs, tapes etc. should be stored in a different location from that containing the current working discs, tapes, etc. and in a safe environment.

Where the CAA has accepted a system for digitised record-keeping satisfying the above, the paper document may be permanently disposed of.

(g) Lost or destroyed records

Reconstruction of lost or destroyed records can be done by reference to other records which reflect the time in service, research of records maintained by maintenance organisations and reference to records maintained by individual mechanics, etc. When reconstruction has been done and the record is still incomplete, the owner/operator may make a statement in the new record describing the loss and establishing the time in service based on the research and the best estimate of time in service. The reconstructed records should be submitted to the CAA for acceptance. The CAA may require the performance of additional maintenance if not satisfied with the reconstructed records.

AMC M.A.305(e)(1) Aircraft Continuing Airworthiness Record System

This retention period of 36 months could be extended in the case of an entry in the technical log system requiring an additional period of retention as defined in this Regulation.

AMC M.A.305(e)(2) Aircraft Continuing Airworthiness Record System

(a) CAA Form 1 and the Certificate of Conformity of the components used to perform a modification/repair are not part of the substantiation data for a modification/repair. These certificates are retained by the maintenance organisation.

(b) In the case of an AD with several steps or with intermediate assessments during its application, these intermediate steps should be part of the detailed maintenance records.

GM M.A.305(e)(2) Aircraft Continuing Airworthiness Record System

'Until such time as the information contained therein is superseded by new information equivalent in scope and detail but not shorter than 36 months' means that during a maximum of 36 months the information and the one superseding it will be kept but, after these 36 months, only the new information must be kept.

For example, for a maintenance task with an interval shorter than 36 months, more than one set of information equivalent in scope and detail should be retained. If the maintenance task interval is longer than 36 months, the last set of information equivalent in scope and detail is retained.

AMC M.A.305(e)(3) Aircraft Continuing Airworthiness Record System

(a) A CAA Form 1 and detailed maintenance records are not required to be kept to support every installation/removal shown in the in-service history records.

(b) Conservative methods to manage missing historical periods are acceptable to establish the current status of the life-limited part. In case of use of a conservative method, the supporting documents should be endorsed. Recommendations from the design approval holder on the procedures to record or reconstruct the in-service history should be considered.

GM M.A.305(e)(3) Aircraft Continuing Airworthiness Record System

(a) CAA Form 1 or equivalent is not required to be kept for the 'condition monitoring' process of components unless this is the means to fulfil another requirement quoted in M.A.305 (e.g. demonstration of AD compliance).

- (b) For components that are not subject to any of the primary maintenance processes described in the GM M.A.305(d)(2) (i.e. Hard Time, On-Condition, Condition Monitoring), the CAA Form 1 or equivalent is not required to be kept.

AMC M.A.305(f) Aircraft Continuing Airworthiness Record System

When the owner or organisation responsible for the aircraft continuing airworthiness arranges for the relevant maintenance organisation to retain copies of the continuing airworthiness records on their behalf, the owner or organisation responsible for the aircraft continuing airworthiness will continue to be responsible for the retention of records. If they cease to be the owner or organisation responsible for the aircraft continuing airworthiness of the aircraft, they also remain responsible for transferring the records to the new owner or organisation.

MCAR-M.A.306 Aircraft Technical Log System

- (a) In addition to the requirements of point M.A.305, for CAT, commercial specialised operations and commercial ATO operations, the operator shall use a technical log system containing the following information for each aircraft:
1. information about each flight, necessary to ensure continued flight safety, and;
 2. the current aircraft certificate of release to service, and;
 3. the current maintenance statement giving the aircraft maintenance status of what scheduled and out of phase maintenance is next due except that the CAA may agree to the maintenance statement being kept elsewhere, and;
 4. all outstanding deferred defects rectifications that affect the operation of the aircraft, and;
 5. any necessary guidance instructions on maintenance support arrangements.
- (b) The initial issue of aircraft technical log system shall be approved by the CAA. Any subsequent amendment to that system shall be managed in accordance with point MCAR-CAMO.A.300(c), or points M.A.704(b) and (c), or point MCAR-CAO.A.025(c).

AMC M.A.306(a) Aircraft Technical Log System

CONTENT OF INFORMATION ON THE ATL SYSTEM

For CAT operations, commercial specialised operations and commercial ATO or commercial DTO operations, the aircraft technical log is a system for recording defects and malfunctions during the aircraft operation and for recording details of all maintenance carried out on an aircraft between scheduled base maintenance visits. In addition, it is used for recording flight safety and maintenance information the operating crew need to know.

Cabin or galley defects and malfunctions that affect the safe operation of the aircraft or the safety of its occupants are regarded as forming part of the aircraft log book where recorded by another means.

The aircraft technical log system may range from a simple single section document to a complex system containing many sections but in all cases it should include the information specified for the example used here which happens to use a 5 section document /computer system:

Section 1 should contain details of the registered name and address of the operator, the aircraft type and the complete international registration marks of the aircraft.

Section 2 should contain details of when the next scheduled maintenance is due, including, if relevant any out of phase component changes due before the next maintenance check. In addition this section should contain the current certificate of release to service (CRS), for the complete aircraft, issued normally at the end of the last maintenance check.

NOTE: The flight crew do not need to receive such details if the next scheduled maintenance is controlled by other means acceptable to the CAA.

Section 3 should contain details of all information considered necessary to ensure continued flight safety. Such information includes:

- (i) the aircraft type and registration mark,
- (ii) the date and place of take-off and landing,
- (iii) the times at which the aircraft took off and landed,
- (iv) the running total of flying hours, such that the hours to the next schedule maintenance can be determined. The flight crew does not need to receive such details if the next scheduled maintenance is controlled by other means acceptable to the CAA.
- (v) details of any failure, defect or malfunction to the aircraft affecting airworthiness or safe operation of the aircraft including emergency systems, and any failure, defect or malfunctions in the cabin or galleys that affect the safe operation of the aircraft or the safety of its occupants that are known to the commander. Provision should be made for the commander to date and sign such entries including, where appropriate, the nil defect state for continuity of the record. Provision should be made for a CRS following rectification of a defect or any deferred defect or maintenance check carried out. Such a certificate appearing on each page of this section should readily identify the defect(s) to which it relates or the particular maintenance check as appropriate.

In the case of maintenance performed by a MCAR-145 maintenance organisation, it is acceptable to use an alternate abbreviated certificate of release to service consisting of the statement 'MCAR-145 release to service' instead of the full certification statement specified in AMC 145.A.50(b) paragraph 1. When the alternate abbreviated certificate of release to service is used, the introductory section of the technical log should include an example of the full certification statement from AMC 145.A.50(b) paragraph 1.

- (vi) the quantity of fuel and oil uplifted and the quantity of fuel available in each tank, or combination of tanks, at the beginning and end of each flight; provision to show, in the same units of quantity, both the amount of fuel planned to be uplifted and the amount of fuel actually uplifted; provision for the time when ground de-icing and/or anti-icing was started and the type of fluid applied, including mixture ratio fluid/water and any other information required by the operator's procedures in order to allow the assessment on whether inspections for and/or elimination of de-icing/anti-icing fluid residues that could endanger flight safety are required.
- (vii) the pre-flight inspection signature.

In addition to the above, it may be necessary to record the following supplementary information:

- the time spent in particular engine power ranges where use of such engine power affects the life of the engine or engine module;
- the number of landings where landings affect the life of an aircraft or aircraft component;
- flight cycles or flight pressure cycles where such cycles affect the life of an aircraft or aircraft component.

NOTE 1: Where Section 3 is of the multi-sector 'part removable' type, then such 'part removable' sections should contain all of the foregoing information where appropriate.

NOTE 2: Section 3 should be designed so that one copy of each page may remain on the aircraft and one copy may be retained on the ground until completion of the flight to which it relates.

NOTE 3: Section 3 layout should be divided to show clearly what is required to be completed after flight and what is required to be completed in preparation for the next flight.

Section 4 should contain details of all deferred defects that affect or may affect the safe operation of the aircraft and should therefore be known to the aircraft commander. Each page of this section should be pre-printed with the operator's name and page serial number and make provision for recording the following:

- (i) a cross reference for each deferred defect such that the original defect can be identified in the particular section 3 sector record page.
- (ii) the original date of occurrence of the defect deferred.
- (iii) brief details of the defect.
- (iv) details of the eventual rectification carried out and its CRS or a clear cross-reference back to the document that contains details of the eventual rectification.

Section 5 should contain any necessary maintenance support information that the aircraft commander needs to know. Such information would include data on how to contact maintenance if problems arise whilst operating the routes etc.

AMC M.A.306(b) Aircraft Technical Log System

The aircraft technical log system can be either a paper or computer system or any combination of both methods acceptable to the CAA.

In case of a computer system, it should contain programme safeguards against the ability of unauthorised personnel to alter the database.

GM1 M.A.306(b) Aircraft technical log system

INTEROPERABLE AIRCRAFT TECHNICAL LOG SYSTEM

If a CAMO is contracted (in accordance with point M.A.201(ea)) by operators that form part of a single air carrier business grouping and intend to regularly transfer aircraft from one AOC holder to another within the group, the CAMO is expected to ensure that:

- there is an interoperable aircraft technical log system for all associated operators; and
- common data formats and data exchange are defined.

MCAR-M.A.307 Transfer of Aircraft Continuing Airworthiness Records

- (a) When an aircraft is permanently transferred from one owner or operator to another, the transferring owner or operator shall ensure that the continuing airworthiness records referred to in point M.A.305 and, if applicable, the technical log system referred to in point M.A.306, are also transferred.

- (b) When the owner contracts the continuing airworthiness management tasks to a CAMO or CAO, the owner shall ensure that the continuing airworthiness records referred to in point M.A.305 are transferred to that contracted organisation.
- (c) The time periods for the retention of records set out in point (e) of point M.A.305 shall continue to apply to the new owner, operator, CAMO or CAO.

AMC M.A.307(a) Transfer of aircraft continuing airworthiness records

Where an owner/operator terminates his operation, all retained continuing airworthiness records should be passed on to the new owner/operator or stored.

A “permanent transfer” does not generally include the dry lease-out of an aircraft when the duration of the lease agreement is less than 6 months. However the CAA should be satisfied that all continuing airworthiness records necessary for the duration of the lease agreement are transferred to the lessee or made accessible to them.

Subpart D — MAINTENANCE STANDARDS

MCAR-M.A.401 Maintenance Data

- (a) The person or organisation maintaining an aircraft shall have access to and use only applicable current maintenance data in the performance of maintenance including modifications and repairs.
- (b) For the purposes of this Regulation, applicable maintenance data is:
 - 1. any applicable requirement, procedure, standard or information issued by the CAA,
 - 2. any applicable airworthiness directive,
 - 3. the applicable instructions for continuing airworthiness and other maintenance instructions, issued by the type-certificate holder, supplementary type certificate holder and any other organisation that publishes such data in accordance with MCAR-21.
 - 4. for components approved for installation by the design approval holder, the applicable maintenance instructions published by the component manufacturers and acceptable to the design approval holder,
 - 5. any applicable data issued in accordance with MCAR-145.A.45(d).
- (c) The person or organisation maintaining an aircraft shall ensure that all applicable maintenance data is current and readily available for use when required. The person or organisation shall establish a work card or worksheet system to be used and shall either transcribe accurately the maintenance data onto such work cards or worksheets or make precise reference to the particular maintenance task or tasks contained in such maintenance data.

GM1 M.A.401(b)(3) and (b)(4) Maintenance data

- (a) The maintenance data referred to in M.A.401(b)(3) and (4) may have been prepared by various organisations, but in any case it needs to be issued by, referenced by, or acceptable to the organisation responsible for the design in accordance with MCAR-21 (e.g. type certificate holder (TCH), supplemental type certificate holder (STCH), ETSO holder, repair design approval holder).
- (b) Depending on the product or component subject to maintenance and depending on how this maintenance is released, different maintenance data may be needed during the performance of maintenance.
- (c) With respect to aircraft maintenance, applicable maintenance data typically includes the following documents issued by the aircraft TCH or the design approval holder (DAH): manufacturer recommended maintenance programme (e.g. MPD, MRBR), aircraft maintenance manual including the airworthiness limitations section, repair manual, supplemental structural inspection document, corrosion prevention and/or control document, service bulletins, wiring diagram manuals, troubleshooting manual, service letter/instructions, illustrated parts catalogue, and any other specific maintenance instruction issued by the aircraft TCH or by the DAH.
- (d) With respect to engine maintenance, applicable maintenance data typically includes the engine maintenance and/or overhaul manual including the airworthiness limitations section, wiring diagrams, parts catalogue, troubleshooting manual issued by the engine TCH (or aircraft TCH if the engine is certified as part of the aircraft) or by the DAH.

With respect to APU maintenance, applicable maintenance data typically includes APU maintenance and/or overhaul manual, wiring diagrams, parts catalogue, troubleshooting manual issued by the aircraft TCH, or issued by the APU manufacturer and acceptable to the TCH of the aircraft on which it is installed or to the DAH.

When in compliance with M.A.502(b), it is possible to conduct maintenance on the engine or APU while installed on the aircraft or temporarily removed to gain access. In such case, the applicable maintenance data may also include aircraft maintenance data.

- (e) With respect to maintenance of components other than engine/APU, applicable maintenance data typically includes the component maintenance (and/or repair) manual, troubleshooting manual and other maintenance instructions produced by the component manufacturer, when they are acceptable to the TCH of the product in which the component is to be installed or to the DAH, or when they form part of (or are referenced together with) the product ICA. In the case of propellers, maintenance data includes its ICA.

When in compliance with M.A.502(b) or M.A.502(c), it is possible to conduct maintenance on the component while installed on the aircraft or engine or APU, or temporarily removed to gain access. In such case, the applicable maintenance data may also include, as applicable, aircraft maintenance data or engine/APU maintenance data.

- (f) With respect to maintenance considered to be specialised services (such as non-destructive testing (NDT)), applicable maintenance data typically includes non-destructive testing or inspection manual, and all applicable specialised service(s) process instructions issued or specified by the DAH.

GM1 M.A.401(b)(4) Maintenance data

COMPONENT MANUFACTURER MAINTENANCE INSTRUCTIONS

The maintenance instructions published by the component manufacturers may be considered acceptable to the DAH – and hence may be used as maintenance data for maintenance on components approved for installation by the DAH – when they are referenced as additional or optional maintenance information together with the ICA, or when documented by a list by that DAH.

AMC M.A.401(c) Maintenance Data

1. Data being made available to personnel maintaining aircraft means that the data should be available in close proximity to the aircraft or component being maintained, for mechanics and certifying staff to perform maintenance.
2. Where computer systems are used, the number of computer terminals should be sufficient in relation to the size of the work programme to enable easy access, unless the computer system can produce paper copies. Where microfilm or microfiche readers/printers are used, a similar requirement is applicable.
3. Maintenance tasks should be transcribed onto the work cards or worksheets and subdivided into clear stages to ensure a record of the accomplishment of the maintenance task. Of particular importance is the need to differentiate and specify, when relevant, disassembly, accomplishment of task, reassembly and testing. In the case of a lengthy maintenance task involving a succession of personnel to complete such task, it may be necessary to use supplementary work cards or worksheets to indicate what was actually accomplished by each individual person. A worksheet or work card system should refer to particular maintenance tasks.

4. The workcard/worksheet system may take the form of, but is not limited to, the following:
 - a format where the mechanic writes the defect and the maintenance action taken together with information of the maintenance data used, including its revision status,
 - an aircraft log book that contains the reports of defects and the actions taken by authorised personnel together with information of the maintenance data used, including its revision status,
 - for maintenance checks, the checklist issued by the manufacturer (i.e., 100H checklist, Revision 5, Items 1 through 95)

5. Maintenance data should be kept up to date by:
 - subscribing to the applicable amendment scheme,
 - checking that all amendments are being received,
 - monitoring the amendment status of all data.

MCAR-M.A.402 Performance of Maintenance

Except for maintenance performed by a maintenance organisation approved in accordance with MCAR-145, any person or organisation performing maintenance shall:

- (a) Be qualified for the tasks performed, as required by this Regulation;
- (b) ensure that the area in which maintenance is carried out is well organised and clean in respect of dirt and contamination;
- (c) use the methods, techniques, standards and instructions specified in the M.A.401 maintenance data;
- (d) use the tools, equipment and material specified in the M.A.401 maintenance data. If necessary, tools and equipment shall be controlled and calibrated to an officially recognised standard;
- (e) ensure that maintenance is performed within any environmental limitations specified in the M.A.401 maintenance data;
- (f) ensure that proper facilities are used in case of inclement weather or lengthy maintenance;
- (g) Ensure that the risk of multiple errors during maintenance and the risk of errors being repeated in identical maintenance tasks are minimised;
- (h) Ensure that an error capturing method is implemented after the performance of any critical maintenance task; and
- (i) Carry out a general verification after completion of maintenance to ensure the aircraft or component is clear of all tools, equipment and any extraneous parts or material, and that all access panels removed have been refitted.

AMC M.A.402(a) Performance of maintenance

1. Maintenance should be performed by persons authorised to issue a certificate of release to service or under the supervision of persons authorised to issue a certificate of release to service. Supervision should be to the extent necessary to ensure that the work is performed properly and the supervisor should be readily available for consultation.
2. The person authorised to issue a certificate of release to service should ensure that:
 - (a) each person working under his/her supervision has received appropriate training or has relevant previous experience and is capable of performing the required task; and
 - (b) each person who performs specialised tasks, such as welding, is qualified in accordance to an officially recognised standard.

GM M.A.402(a) Performance of Maintenance

In the case of limited Pilot-owner maintenance, as specified in M.A.803, any person maintaining an aircraft which they own individually or jointly, provided they hold a valid pilot licence with the appropriate type or class rating, may perform the limited Pilot-owner maintenance tasks in accordance with Appendix VIII to this Regulation.

AMC M.A.402(c) Performance of Maintenance

The general maintenance and inspection standards applied to individual maintenance tasks should meet the recommended standards and practices of the organisation responsible for the type design, which are normally published in maintenance manuals. In the absence of maintenance and inspection standards published by the organisation responsible for the type design, maintenance personnel should refer to the relevant aircraft airworthiness standards and procedures published or used as guidance by the CAA. The maintenance standards used should contain methods, techniques and practices acceptable to the CAA for the maintenance of the aircraft and its components.

AMC M.A.402(d) Performance of Maintenance

When performing the maintenance, personnel are required to use the tools, equipment and test apparatuses necessary to ensure completion of work in accordance with accepted maintenance and inspection standards. Inspection, service or calibration that is performed on a regular basis should be performed in accordance with the equipment manufacturers' instructions. All tools requiring calibration should be traceable to an acceptable standard.

In this context, "officially recognised standards" means those standards established or published by an official body, being either a natural or legal person, and which are widely recognised by the air transport sector as constituting good practice.

If the organisation responsible for the type design involved recommends special equipment or test apparatuses, personnel should use the recommended equipment or apparatuses or equivalent equipment accepted by the CAA.

All work should be performed using material of such quality and in such a manner that the condition of the aircraft or its component after maintenance is at least equal to its or their original or modified condition (with regard to aerodynamic function, structural strength, resistance to vibration, deterioration and any other qualities affecting airworthiness).

AMC M.A.402(e) Performance of Maintenance

The working environment should be appropriate for the maintenance task being performed such that the effectiveness of personnel is not impaired.

- (a) Temperature should be maintained such that personnel can perform the required tasks without undue discomfort.
- (b) Airborne contamination (e.g. dust, precipitation, paint particles, filings) should be kept to a minimum to ensure aircraft/components surfaces are not contaminated, if this is not possible all susceptible systems should be sealed until acceptable conditions are re-established.
- (c) Lighting should be adequate to ensure each inspection and maintenance task can be performed effectively.
- (d) Noise levels should not be allowed to rise to the level of distraction for inspection staff or if this is not possible inspection staff should be provided with personnel equipment to reduce excessive noise.

AMC M.A.402(f) Performance of Maintenance

Facilities should be provided appropriate for all planned maintenance. This may require aircraft hangars that are both available and large enough for the planned maintenance.

Aircraft component workshops should be large enough to accommodate the components that are planned to be maintained.

Protection from inclement weather means the hangar or component workshop structures should be to a standard that prevents the ingress of rain, hail, ice, snow, wind and dust etc.

AMC M.A.402(g) Performance of Maintenance

(a) To minimise the risk of multiple errors and to prevent omissions, the person or organisation performing maintenance should ensure that:

- (1) every maintenance task is signed off only after completion;
- (2) the grouping of tasks for the purpose of sign-off allows critical steps to be clearly identified; and
- (3) any work performed by personnel under supervision (i.e. temporary staff, trainees) is checked and signed off by an authorised person.

(b) To minimise the possibility of an error being repeated in identical tasks that involve removal/installation or assembly/disassembly of several components of the same type fitted to more than one system, whose failure could have an impact on safety, the person or organisation performing maintenance should plan different persons to perform identical tasks in different systems. However, when only one person is available, then this person should perform reinspection of the tasks as described in AMC2 M.A.402(h).

AMC1 M.A.402(h) Performance of Maintenance

CRITICAL MAINTENANCE TASKS

The following maintenance tasks should primarily be reviewed to assess their impact on safety:

- (a) Tasks that may affect the control of the aircraft, flight path and attitude, such as installation, rigging and adjustments of flight controls;
- (b) Aircraft stability control system (autopilot, fuel transfer);
- (c) Tasks that may affect the propulsive force of the aircraft, including installation of aircraft engines, propellers and rotors; and
- (d) Overhaul, calibration or rigging of engines, propellers, transmission and gearboxes.

AMC2 M.A.402(h) Performance of Maintenance
INDEPENDENT INSPECTIONS

(a) What is an independent inspection

Independent inspection is one possible error-capturing method. It consists of an inspection performed by an “independent qualified person” of a task carried out by an “authorised person”, taking into account that:

- (1) The “authorised person” is the person who performs the tasks or supervises the task and assumes the full responsibility for the completion of the task in accordance with the applicable maintenance data;
- (2) The “independent qualified person” is the person who performs the independent inspection and attests the satisfactory completion of the task and that no deficiencies have been found. The “independent qualified person” does not issue a certificate of release to service, therefore he/she is not required to hold certification privileges;
- (3) The certificate of release to service is issued by the “authorised person” after the independent inspection has been carried out satisfactorily;
- (4) The work card should record the identification of each person, the date and the details of the independent inspection, as necessary, before the certificate of release to service is issued.

(b) Qualifications of personnel performing independent inspections

- (1) When the work is performed by MCAR-M Subpart F organisation, then the organisation should have procedures to demonstrate that the “independent qualified person” has been trained and has gained experience in the specific control systems to be inspected. This training and experience could be demonstrated, for example, by:
 - (i) holding a MCAR-66 licence in the same subcategory as the licence subcategory or equivalent necessary to release or sign off the critical maintenance task;
 - (ii) holding a MCAR-66 licence in the same category and specific training in the task to be inspected; or
 - (iii) having received appropriate training and having gained relevant experience in the specific task to be inspected.
- (2) When the work is performed outside an MCAR-M Subpart F organisation:
 - (i) the “independent qualified person” should hold:
 - (A) an MCAR-66 licence in any category or equivalent; or
 - (B) a valid pilot licence for the aircraft type issued in accordance with MCAR-Air Operations regulation or equivalent;
 - (ii) additionally, the “authorised person” should assess the qualifications and experience of the “independent qualified person” taking into account that the “independent qualified

person” should have received training and experience in the particular task. It should not be acceptable that the “authorised person” shows to the “independent qualified person” how to perform the inspection once work has been already finalised.

(c) How should independent inspection be performed

Independent inspection should ensure for example correct assembly, locking and sense of operation. When inspecting control systems that have undergone maintenance, the ‘independent qualified person’ should consider the following points independently:

- (1) all those parts of the system that have actually been disconnected or disturbed should be inspected for correct assembly and locking;
- (2) the system as a whole should be inspected for full and free movement over the complete range;
- (3) cables should be tensioned correctly with adequate clearance at secondary stops;
- (4) the operation of the control system as a whole should be observed to ensure that the controls are operating in the correct sense;
- (5) if different control systems are interconnected so that they effect other, all the interactions should be checked through the full range of the applicable controls; and
- (6) software that is part of the critical maintenance task should be checked, for example version and compatibility with the aircraft configuration.

(d) What do in unforeseen cases when only one person is available

REINSPECTION

- (1) Reinspection is subject to the same conditions as the independent inspection is, except that the “authorised person” performing the maintenance task is also acting as “independent qualified person” and performs the inspection.
- (2) For critical maintenance tasks, reinspection should only be used in unforeseen circumstances when only one person is available to carry out the task and perform the independent inspection. The circumstances cannot be considered unforeseen if the person or organisation has not assigned a suitable “independent qualified person” to that particular task.
- (3) The certificate of release to service is issued by the “authorised person” after the reinspection has been performed satisfactorily.
- (4) The work card system should record identification of the “authorised person” and the date and the details of the reinspection, as necessary, before the certificate of release to service is issued.

GM M.A.402(h) Performance of Maintenance

Several data sources may be used for identification of critical maintenance tasks, such as:

- Information from the design approval holder;
- Accident reports;
- Investigation and follow-up of incidents;
- Occurrence reporting;
- Flight data analysis;
- Results of audits;
- Normal operations monitoring schemes;
- Feedback from training and
- Information exchange systems.

MCAR-M.A.403 Aircraft Defects

- (a) Any aircraft defect that hazards seriously the flight safety shall be rectified before further flight.
- (b) Only the certifying staff referred to in point M.A.801(b)(1) or in Subpart F of this Regulation or in MCAR-145 or in MCAR-CAO, or the person authorised in accordance with point M.A.801(c) of this Regulation can decide, using maintenance data referred to in point M.A.401 of this Regulation, whether an aircraft defect hazards seriously the flight safety and therefore decide when and which rectification action shall be taken before further flight and which defect rectification can be deferred. However, this does not apply when the MEL is used by the pilot or by the certifying staff.
- (c) Any aircraft defect that would not hazard seriously the flight safety shall be rectified as soon as practicable, after the date the aircraft defect was first identified and within any limits specified in the maintenance data or the MEL.
- (d) Any defect not rectified before flight shall be recorded in the aircraft continuing airworthiness record system referred to in point M.A.305 or, if applicable in the aircraft technical log system referred to in point M.A.306.

AMC M.A.403(b) Aircraft Defects

An assessment of both the cause and any potentially hazardous effect of any defect or combination of defects that could affect flight safety should be made in order to initiate any necessary further investigation and analysis necessary to identify the root cause of the defect.

AMC M.A.403(d) Aircraft Defects

All deferred defects should be made known to the pilot/flight crew, whenever possible, prior to their arrival at the aircraft.

Deferred defects should be transferred on to worksheets at the next appropriate maintenance check, and any deferred defect which is not rectified during the maintenance check, should be re-entered on to a new deferred defect record sheet. The original date of the defect should be retained.

The necessary components or parts needed for the rectification of defects should be made available or ordered on a priority basis, and fitted at the earliest opportunity.

Subpart E — COMPONENTS

MCAR-M.A.501 **Classification and Installation**

- (a) All components shall be classified into the following categories:
- (1) Components which are in a satisfactory condition, released on a CAA Form 1 or equivalent and marked in accordance with Subpart Q of MCAR-21, unless otherwise specified in point MCAR-21.A.307 or in this Regulation or in MCAR-CAO.
 - (2) Unserviceable components which shall be maintained in accordance with this Regulation.
 - (3) Components categorised as unsalvageable because they have reached their mandatory life limitation or contain a non-repairable defect.
 - (4) Standard parts used on an aircraft, engine, propeller or other aircraft component when specified in the maintenance data and accompanied by evidence of conformity traceable to the applicable standard.
 - (5) Material both raw and consumable used in the course of maintenance when the organisation is satisfied that the material meets the required specification and has appropriate traceability. All materials must be accompanied by documentation clearly relating to the particular material and containing a conformity to specification statement plus both the manufacturing and supplier source.
- (b) Components, standard parts and material shall only be installed on an aircraft or a component when they are in a satisfactory condition, belong to one of the categories listed in point (a) and the applicable maintenance data specifies the particular component, standard part or material.

AMC1 M.A.501(a)(1) Classification and Installation

CAA FORM 1 or Equivalent

- (a) A document equivalent to a CAA Form 1 may be:
- (1) a release document issued by an organisation under the terms of a bilateral agreement signed by the Maldives;
 - (2) an EASA Form 1;
 - (3) an FAA Form 8130-3;
 - (4) a Transport Canada TCCA 24-0078 or Authorised Release Certificate Form One;
 - (5) a UK CAA Form 1 within the framework of the EU-UK trade agreement;
 - (6) (reserved);
 - (7) reserved;
 - (8) reserved;
 - (9) a 'declaration of maintenance accomplished' issued by the person or organisation that performed the maintenance, as specified in point M.A.502(e), or ML.A.502(c) where applicable.
- (b) Any item in storage without a CAA Form 1 or equivalent cannot be installed on aircraft registered in the Maldives unless a CAA Form 1 is issued for such item by an appropriately approved maintenance organisation in accordance with AMC M.A.613 (a) or AMC1 CAO.A.070(a) or AMC2 145.A.50(d).

GM1 M.A.501(a)(1) Classification and installation

Point (b) of MCAR-21.A.307 specifies new components that do not need a CAA Form 1 or equivalent to be eligible for installation. Point (c) of MCAR-21.A.307 specifies the conditions for the document accompanying the component.

GM1 M.A.501(a)(2) Classification and Installation

UNSERVICEABLE COMPONENTS

- (a) The person or organisation that performs maintenance should ensure the proper identification of any unserviceable components. The unserviceable status of the component should be clearly declared on a tag together with the component identification data and any information that is useful to define actions that are necessary to be taken. Such information should state, as applicable, in-service times, maintenance status, preservation status, failures, defects or malfunctions reported or detected, exposure to adverse environmental conditions, and whether the component is installed on an aircraft that was involved in an accident or incident. Means should be provided to prevent unintentional separation of this tag from the component.
- (b) Unserviceable components should typically undergo maintenance due to:
- (1) expiry of the service life limit as defined in the aircraft maintenance programme;

- (2) non-compliance with the applicable airworthiness directives and other continuing airworthiness requirements mandated by the CAA;
- (3) absence of the necessary information to determine the airworthiness status or eligibility for installation;
- (4) evidence of defects or malfunctions;
- (5) being installed on an aircraft that was involved in an incident or accident likely to affect the component's serviceability.

AMC1 M.A.501(a)(3) Classification and Installation
UNSALVAGEABLE COMPONENTS

The following types of components should typically be classified as unsalvageable:

- (a) components with non-repairable defects, whether visible or not to the naked eye;
- (b) components that do not meet design specifications, and cannot be brought into conformity with such specifications;
- (c) components subjected to unacceptable modification or rework that is irreversible;
- (d) life-limited parts that have reached or exceeded their mandatory life limitation, or have missing or incomplete records;
- (e) components whose airworthy condition cannot be restored due to exposure to extreme forces, heat or adverse environmental conditions;
- (f) components for which conformity with an applicable airworthiness directive cannot be accomplished;
- (g) components for which maintenance records and/or traceability to the manufacturer cannot be retrieved.

AMC1 M.A.501(a)(4) Classification and installation
STANDARD PARTS

- (a) Standard parts are parts that are manufactured in complete compliance with an established industry, EASA, CAA or other government specification which include design, manufacturing, test and acceptance criteria, and uniform identification requirements. The specification should include all the information that is necessary to produce and verify conformity of the part. It should be published so that any party may manufacture the part. Examples of such specifications are National Aerospace Standards (NAS), Army-Navy Aeronautical Standard (AN), Society of Automotive Engineers (SAE), SAE Sematec, Joint Electron Device Engineering Council, Joint Electron Tube Engineering Council, and American National Standards Institute (ANSI), EN Specifications, etc.
- (b) To designate a part as a standard part, the TC holder may issue a standard parts manual accepted by the competent authority of the original TC holder or may make reference in the parts catalogue

to the specification to be met by the standard part. Documentation that accompanies standard parts should clearly relate to the particular parts and contain a conformity statement plus both the manufacturing and supplier source. Some materials are subject to special conditions, such as storage conditions or life limitation, etc., and this should be included in the documentation and/or the material's packaging.

- (c) A CAA Form 1 or equivalent is not normally issued and, therefore, none should be expected.

AMC2 M.A.501(a)(4) Classification and installation

STANDARD PARTS

For sailplanes and powered sailplanes, non-required instruments and/or equipment that are certified under the provision of EASA CS 22.1301(b), if those instruments or equipment, when installed, functioning, functioning improperly or not functioning at all, do not in themselves, or by their effect upon the sailplane and its operation, constitute a safety hazard.

'Required' in the term 'non-required', as used above, means required by the applicable airworthiness code (EASA CS 22.1303, 22.1305 and 22.1307) or required by the relevant regulations for air operations and the applicable Rules of the Air or as required by air traffic management (e.g. a transponder in certain controlled airspace). Examples of non-required equipment which can be considered to be standard parts may be electrical variometers, bank/slip indicators ball-type, total energy probes, capacity bottles (for variometers), final glide calculators, navigation computers, data logger/barograph/turnpoint camera, bug-wipers and anti-collision systems. Equipment which must be approved in accordance with the airworthiness code shall comply with the applicable ETSO or equivalent and it is not considered to be a standard part (e.g. oxygen equipment).

AMC M.A.501(a)(5) Classification and installation

MATERIAL

- (a) Consumable material is any material which is only used once, such as lubricants, cements, compounds, paints, chemical dyes and sealants, etc.
- (b) Raw material is any material that requires further work to make it into a component part of the aircraft, such as metals, plastics, wood, fabric, etc.
- (c) Material both raw and consumable should only be accepted when satisfied that it is to the required specification. To be satisfied, the material and/or its packaging should be marked with the applicable specification and, where appropriate, the batch number.
- (d) Documentation that accompanies all materials should clearly relate to the particular material and contain a conformity statement plus both the manufacturing and supplier source. Some materials are subject to special conditions, such as storage conditions or life limitation, etc., and this should be included in the documentation and/or the material's packaging.
- (e) CAA Form 1 or equivalent should not be issued for such materials and, therefore, none should be expected. The material specification is normally identified in the (S)TC holder's data except in the case where the CAA has agreed otherwise.

GM1 M.A.501(b) Classification and Installation

- (a) To ensure that components, standard parts and materials are in satisfactory condition, the persons referred to under M.A.801(b)(2), M.A.801(b)(3), M.A.801(c) or M.A.801(d), or the approved maintenance organisation should perform an incoming physical inspection.
- (b) The incoming physical inspection should be performed before the component is installed on the aircraft.
- (c) The following list, although not exhaustive, contains typical checks to be performed:
 - (1) verify the general condition of the components and their packaging in relation to damages that could affect their integrity;
 - (2) verify that the shelf life of the component has not expired;
 - (3) verify that items are received in the appropriate package in respect of the type of the component: e.g. correct ATA 300 or electrostatic sensitive devices packaging, when necessary;
 - (4) verify that the component has all plugs and caps appropriately installed to prevent damage or internal contamination. Care should be taken when tape is used to cover electrical connections or fluid fittings/openings because adhesive residues can insulate electrical connections and contaminate hydraulic or fuel units.
 - (5) verify that the release certificate accompanying each new component satisfies the release requirements established in point MCAR-21.A.307 as applicable in relation to the particular product on which the component is being installed.
- (d) Items (e.g. fasteners) purchased in batches should be supplied in a package. The packaging should state the applicable specification/standard, P/N, batch number, and the quantity of the items. The documentation that accompanies the material should contain the applicable specification/standard, P/N, batch number, supplied quantity, and the manufacturing sources. If the material is acquired from different batches, acceptance documentation for each batch should be provided.

GM2 M.A.501(b) Classification and Installation
INSTALLATION OF COMPONENTS

Components, standard parts and materials should only be installed when they are specified in the applicable maintenance data as specified in MCAR-M.A.401(b). So, a component, standard part and material can only be installed after having checked the applicable maintenance data.

This check should ensure that the part number, modification status, limitations, etc., of the component, standard part or material are the ones specified in the applicable maintenance data of the particular aircraft or component where the component, standard part or material is going to be installed. When the installation is performed outside a maintenance organisation, that is by the persons referred to in M.A.801(b)(1), M.A.801(b)(2), or M.A.801(c), then these persons are responsible to perform this check before installation. When the installation is performed by a MCAR-M Subpart F organisation or an organisation approved in accordance with MCAR-CAO, then the organisation has to establish procedures to ensure that this check is performed before installation.

MCAR-M.A.502 Component Maintenance

- (a) The maintenance of components other than the components referred to in points (b)(2) to (b)(6) of point MCAR-21.A.307 shall be performed by maintenance organisations approved in accordance with Subpart F of this Regulation or with MCAR-145 or with MCAR-CAO, as applicable.
- (b) By way of derogation from point (a), where a component is fitted to the aircraft, the maintenance of such component may be performed by an aircraft maintenance organisation approved in accordance with Subpart F of this Regulation or with MCAR-145 or with MCAR-CAO or by certifying staff referred to in point (b)(1) of point M.A.801. Such maintenance shall be performed in accordance with the aircraft maintenance data or in accordance with the component maintenance data if agreed by the CAA. Such aircraft maintenance organisation or certifying staff may temporarily remove the component for maintenance if this is necessary to improve access to the component, except where additional maintenance is required due to the removal. Component maintenance performed in accordance with this point shall not be eligible for the issuance of a CAA Form 1 and shall be subject to the aircraft release requirements provided for in point M.A.801.
- (c) By way of derogation from point (a), where a component is fitted to the engine or Auxiliary Power Unit (APU), the maintenance of such component may be performed by an engine maintenance organisation approved in accordance with Subpart F of this Regulation, or with MCAR-145 or with MCAR-CAO. Such maintenance shall be performed in accordance with the engine or the APU maintenance data or in accordance with the component maintenance data if agreed by the CAA. Such engine maintenance organisation may temporarily remove the component for maintenance if this is necessary to improve access to the component, except where additional maintenance is required due to the removal.
- (d) The maintenance of components referred to in point (b)(2) of point 21.A.307 of MCAR-21, where the component is fitted to the aircraft or is temporarily removed to improve access, shall be performed by an aircraft maintenance organisation approved in accordance with Subpart F of this Regulation or with MCAR-145 or with MCAR-CAO, as applicable, by certifying staff referred to in point (b)(1) of point M.A.801 or by the pilot-owner referred to in point (b)(2) of point M.A.801. Component maintenance performed in accordance with this point is not eligible for the issuance of a CAA Form 1 and shall be subject to the aircraft release requirements provided for in point M.A.801.
- (e) The maintenance of components referred to in points (b)(3) to (b)(6) of point 21.A.307 of MCAR-21 shall be performed by the organisation referred to in point (a), or performed by any person or organisation and released with a “declaration of maintenance accomplished” issued by the person or organisation that performed the maintenance. The “declaration of maintenance accomplished” shall contain at least basic details of the maintenance carried out, the date on which the maintenance was completed, and the identification of the organisation or person that issues it. It shall be considered a maintenance record and equivalent to a CAA Form 1 in respect of the maintained component.

GM1 M.A.502(e) Component maintenance

A ‘declaration of maintenance accomplished’ is a certificate prepared in any shape/form by the person or organisation that performed any maintenance on the component covered by the certificate and subject to the conditions in M.A.502(e). This person or organisation does not need an approval to perform maintenance in accordance with MCAR-A. In order for the component to be eligible for installation with a ‘declaration of maintenance accomplished’, this declaration, together with other records, should allow the determination that the component was first installed as ‘new’, as a component referred to in M.A.502(e).

Such a component should not be installed in an aircraft if there is information on the certificate which is not readable or not understandable or states that the component is not in a satisfactory condition for operation.

AMC M.A.502 Component Maintenance

Component removal from and installation on an aircraft is considered to be aircraft maintenance and not component maintenance. As a consequence, M.A.502 requirements do not apply to this case.

AMC M.A.502(b) and (c) Component Maintenance

M.A.502(b) and (c) allow the performance of certain component maintenance, in accordance with component maintenance data, to maintenance organisations not holding the corresponding B/C rating and to independent certifying staff, subject to the agreement of CAA.

This should only be permitted by the CAA in the case of simple component maintenance, where the CAA is satisfied that the certifying staff are appropriately qualified and the proper tooling and facilities are available. It is important to note that for more complex component maintenance, special qualifications may be required and it is not enough with holding an MCAR-66 aircraft maintenance licence.

MCAR-M.A.503 Life-limited Parts and time-controlled components

- (a) Installed life-limited parts and time-controlled components shall not exceed the approved service life limit as specified in the AMP and ADs, except as provided for in point M.A.504(b).
- (b) When the approved limitation expires, the component shall be removed from the aircraft for maintenance, or for disposal in the case of life-limited parts.

MCAR-M.A.504 Segregation of components

- (a) Unserviceable and unsalvageable components shall be segregated from serviceable components, standards parts and materials.
- (b) Unsalvageable components shall not be permitted to re-enter the component supply system unless the mandatory life limitation has been extended or a repair solution has been approved in accordance with M.A.304.

AMC1 M.A.504 Segregation of components

- (a) Unserviceable components should be identified and stored in a separate secure location that is managed by the maintenance organisation until a decision is made on the future status of such components. Certifying staff outside maintenance organisations (M.A.801(b)(1), or M.A.801(c)) that release aircraft maintenance should send, with the agreement of the aircraft owner/lessee, any unserviceable component to a maintenance organisation for controlled storage. Nevertheless, the person or organisation that declared the component unserviceable may transfer its custody, after identifying it as unserviceable, to the aircraft owner/lessee provided that such transfer is reflected in the aircraft logbook, or engine logbook, or component logbook.
- (b) ‘Secure location under the control of an approved maintenance organisation’ refers to a location that is managed by the approved maintenance organisation that prevents the component from being reused or tampered with. This may include facilities that are established by the organisation at locations different from the main maintenance facilities. These locations should be identified in the relevant procedures of the organisation.
- (c) In the case of unsalvageable components, the person or organisation should:
 - (1) retain such components in the secure location referred to in paragraph (b);
 - (2) arrange for the component to be mutilated in a manner that ensures that it cannot be restored for use, before disposing it; or
 - (3) mark the component indicating that it is unsalvageable, when, in agreement with the component owner, the component is disposed of for legitimate non-flight uses (such as training and education aids, research and development), or for non-aviation applications, mutilation is often not appropriate. Alternatively to marking, the original part number or data plate information can be removed, or a record kept of the disposal of the component for legitimate non-flight uses.

GM1 M.A.504 Segregation of components

MUTILATION OF COMPONENTS

- (a) Mutilation should be accomplished in such a manner that the components become permanently unusable for their original intended use. Mutilated components should not be able to be reworked or camouflaged to provide the appearance of being serviceable, such as by replating, shortening and re-threading long bolts, welding, straightening, machining, cleaning, polishing, or repainting.
- (b) Mutilation may be accomplished by one or a combination of the following procedures:
 - (1) grinding,
 - (2) burning,
 - (3) removal of a major lug or other integral feature,
 - (4) permanent distortion of parts,
 - (5) cutting a hole with cutting torch or saw,
 - (6) melting,
 - (7) sawing into many small pieces,
 - (8) any other method accepted by the CAA.
- (c) The following procedures are examples of mutilation that are often less successful because they may not be consistently effective:
 - (1) stamping or vibro-etching,
 - (2) spraying with paint,
 - (3) small distortions, incisions or hammer marks,
 - (4) identification by tag or markings,
 - (5) drilling small holes,
 - (6) sawing in two pieces only.

Subpart F — MAINTENANCE ORGANISATION

MCAR-M.A.601 Scope

This Subpart establishes the requirements to be met by an organisation to qualify for the issue or continuation of an approval for the maintenance of aircraft other than complex motor powered aircraft and components to be installed therein not used by licenced air carriers.

MCAR-M.A.602 Application

An application for issue or change of a maintenance organisation approval shall be made on a form and in a manner established by the CAA.

AMC M.A.602 Application

An application should be made on a CAA Form 2 (Appendix IX to AMC M.A.602 and AMC M.A.702) or equivalent acceptable to the CAA.

The CAA Form 2 is valid for the application for M.A. Subpart F, MCAR-145, MCAR-M.A Subpart G, MCAR-CAMO and MCAR-CAO organisations. Organisations applying for several approvals may do so by using a single CAA Form 2.

MCAR-M.A.603 Extent of approval

- (a) An organisation involved in activities subject to this Subpart shall not exercise its activities unless approved by the CAA. Appendix V to this Regulation provides the template certificate for this approval.
- (b) The scope of work subject to approval shall be specified in the maintenance organisation manual in accordance with point M.A.604. Classes and ratings to be used for the approval of maintenance organisations are set out in Appendix IV of this Regulation..
- (c) An approved maintenance organisation may fabricate, in conformity with maintenance data, a restricted range of parts for the use in the course of undergoing work within its own facilities, as identified in the maintenance organisation manual.

AMC M.A.603(a) Extent of approval

The following table identifies the ATA specification 2200 chapter for the category C component rating. If the maintenance manual (or equivalent document) does not follow the ATA Chapters, the corresponding subjects still apply to the applicable C rating.

CLASS	RATING	ATA CHAPTERS
COMPONENTS OTHER THAN COMPLETE ENGINES OR APUs	C1 Air Cond & Press	21
	C2 Auto Flight	22
	C3 Comms and Nav	23 - 34
	C4 Doors - Hatches	52
	C5 Electrical Power & Lights	24 - 33 - 85
	C6 Equipment	25 - 38 - 44 - 45 - 50
	C7 Engine – APU	49 - 71 - 72 - 73 - 74 - 75 - 76 - 77 - 78 - 79 - 80 - 81 - 82 - 83
	C8 Flight Controls	27 - 55 - 57.40 - 57.50 -57.60 - 57.70
	C9 Fuel	28 - 47
	C10 Helicopters - Rotors	62 - 64 - 66 - 67
	C11 Helicopter - Trans	63 - 65
	C12 Hydraulic Power	29
	C13 Indicating/Recording Systems	31 – 42 - 46
	C14 Landing Gear	32
	C15 Oxygen	35
	C16 Propellers	61
	C17 Pneumatic & Vacuum	36 - 37
	C18 Protection ice/rain/fire	26 - 30
	C19 Windows	56
	C20 Structural	53 - 54 - 57.10 - 57.20 - 57.30
	C21 Water Ballast	41
	C22 Propulsion Augmentation	84

AMC M.A.603(c) Extent of approval

1. The agreement by the CAA for the fabrication of parts by the approved maintenance organisation should be formalised through the approval of a detailed procedure in the maintenance organisation manual. This AMC contains principles and conditions to be taken into account for the preparation of an acceptable procedure.
2. Fabrication, inspection, assembly and test should be clearly within the technical and procedural capability of the approved maintenance organisation.
3. The approved data necessary to fabricate the part are those approved either by the CAA, the TC holder, MCAR-21 design organisation approval holder, or STC holder.
4. Items fabricated by an approved maintenance organisation may only be used by that organisation

in the course of overhaul, maintenance, modifications, or repair of aircraft or components undergoing work within its own facility. The permission to fabricate does not constitute approval for manufacture, or to supply externally and the parts do not qualify for certification on CAA Form 1. This also applies to the bulk transfer or surplus inventory, in that locally fabricated parts are physically segregated and excluded from any delivery certification.

5. Fabrication of parts, modification kits etc for onward supply and/or sale may not be conducted under a M.A. Subpart F approval
6. The data specified in paragraph 3 may include repair procedures involving the fabrication of parts. Where the data on such parts is sufficient to facilitate fabrication, the parts may be fabricated by an approved maintenance organisation. Care should be taken to ensure that the data include details of part numbering, dimensions, materials, processes, and any special manufacturing techniques, special raw material specification or/and incoming inspection requirement and that the approved organisation has the necessary capability. That capability should be defined by way of maintenance organisation manual content. Where special processes or inspection procedures are defined in the approved data which are not available at the approved maintenance organisation, that organisation cannot fabricate the part unless the TC/STC-holder gives an approved alternative.
7. Examples of fabrication under the scope of an M.A. Subpart F approval can include but are not limited to the following:
 - (a) fabrication of bushes, sleeves and shims,
 - (b) fabrication of secondary structural elements and skin panels,
 - (c) fabrication of control cables,
 - (d) fabrication of flexible and rigid pipes,
 - (e) fabrication of electrical cable looms and assemblies,
 - (f) formed or machined sheet metal panels for repairs.

Note: It is not acceptable to fabricate any item to pattern unless an engineering drawing of the item is produced which includes any necessary fabrication processes and which is accepted to the CAA.

8. Where a TC-holder or an approved production organisation is prepared to make available complete data which is not referred to in aircraft manuals or service bulletins but provides manufacturing drawings for items specified in parts lists, the fabrication of these items is not considered to be within the scope of an M.A. Subpart F approval unless agreed otherwise by the CAA in accordance with a procedure specified in the maintenance organisation manual.

9. Inspection and Identification.

Any locally fabricated part should be subject to an inspection stage before, separately, and preferably independently from, any inspection of its installation. The inspection should establish full compliance with the relevant manufacturing data, and the part should be unambiguously identified as fit for use by stating conformity to the approved data. Adequate records should be maintained of all such fabrication processes including heat treatment and the final inspections. All parts, excepting those with inadequate space, should carry a part number which clearly relates it to the

manufacturing/inspection data. Additional to the part number the approved maintenance organisation's identity should be marked on the part for traceability purposes.

MCAR-M.A.604 Maintenance organisation manual

- (a) The maintenance organisation shall provide a manual containing at least the following information:
1. a statement signed by the accountable manager appointed in accordance with point M.A.606(a), which confirms that the organisation will at all times carry out its activities in accordance with the requirements of MCAR-M or MCAR-ML, as applicable, and with the manual;
 2. the organisation's scope of work, and;
 3. the title(s) and name(s) of person(s) referred to in M.A.606(b), and;
 4. an organisation chart showing associated chains of responsibility between the person(s) referred to in M.A.606(b), and;
 5. a list of certifying staff and, if applicable, airworthiness review staff with their scope of approval, and;
 6. a list of locations where maintenance is carried out, together with a general description of the facilities, and;
 7. procedures specifying how the maintenance organisation ensures compliance with this Regulation, and;
 8. the maintenance organisation manual amendment procedure(s).
- (b) The maintenance organisation manual and its amendments shall be approved by the CAA.
- (c) Notwithstanding point (b) minor amendments to the manual may be approved through a procedure (hereinafter called indirect approval).

AMC M.A.604 Maintenance organisation manual

1. Appendix IV to this AMC provides an outline of the format of an acceptable maintenance organisation manual for a small organisation with less than 10 maintenance staff.
2. The maintenance organisation exposition as specified in MCAR-145 provides an outline of the format of an acceptable maintenance organisation manual for larger organisations with more than 10 maintenance staff, dependent upon the complexity of the organisation.

MCAR-M.A.605 Facilities

The organisation shall ensure that:

- (a) Facilities are provided for all planned work, specialised workshops and bays are segregated as appropriate, to ensure protection from contamination and the environment.
- (b) Office accommodation is provided for the management of all planned work including in particular, the completion of maintenance records.
- (c) Secure storage facilities are provided for components, equipment, tools and material. Storage conditions shall ensure segregation of unserviceable components and material from all other components, material, equipment and tools. Storage conditions shall be in accordance with the manufacturers' instructions and access shall be restricted to authorised personnel.

AMC M.A.605(a) Facilities

1. Where a hangar is not owned by the M.A. Subpart F organisation, it may be necessary to establish proof of tenancy. In addition, sufficiency of hangar space to carry out planned maintenance should be demonstrated by the preparation of a projected aircraft hangar visit plan relative to the aircraft maintenance programme. The aircraft hangar visit plan should be updated on a regular basis.

For balloons and airships a hangar may not be required where maintenance of the envelope and bottom end equipment can more appropriately be performed outside, providing all necessary maintenance can be accomplished in accordance with M.A.402 or ML.A.402. For complex repairs or component maintenance requiring a CAA Form 1, suitable approved workshops should be provided. The facilities and environmental conditions required for inspection and maintenance should be defined in the Maintenance Organisation Manual

Depending on the scope of work of the maintenance organisation, it may not be necessary to have a hangar available. For example, an organisation maintaining ELA2 aircraft (when not performing major repairs) may perform the work in alternative suitable facilities (and possibly at remote locations) as agreed by the CAA.

2. Protection from the weather elements relates to the normal prevailing local weather elements that are expected throughout any twelve-month period. Aircraft hangar and aircraft component workshop structures should be to a standard that prevents the ingress of rain, hail, ice, snow, wind and dust etc. Aircraft hangar and aircraft component workshop floors should be sealed to minimise dust generation.
3. Aircraft maintenance staff should be provided with an area where they may study maintenance instructions and complete continuing airworthiness records in a proper manner.

4. **Special case for ELA2 aircraft**

For ELA2 aircraft, it is acceptable not to have access to a hangar or dedicated workshops. Depending on the scope of work, other facilities are acceptable as long as protection is ensured from inclement weather and contamination. This may include, for example, working in the field or in non-aviation premises (closed or not).

These facilities do not need to be individually approved by the CAA as long as the maintenance organisation manual describes for each type of facility the scope of work, the tooling and equipment available, and the permitted environmental conditions (weather, contamination).

The organisation should include, as part of the periodic internal organisational review, a sampling of the compliance with these conditions during certain maintenance events.

AMC M.A.605(b) Facilities

It is acceptable to combine any or all of the office accommodation requirements into one office subject to the staff having sufficient room to carry out assigned tasks.

AMC M.A.605(c) Facilities

1. Storage facilities for serviceable aircraft components should be clean, well-ventilated and maintained at an even dry temperature to minimise the effects of condensation. Manufacturer's storage recommendations should be followed for those aircraft components identified in such published recommendations.
2. Adequate storage racks should be provided and strong enough to hold aircraft components and provide sufficient support for large aircraft components such that the component is not damaged during storage.
3. All aircraft components, wherever practicable, should remain packaged in their protective material to minimise damage and corrosion during storage. A shelf life control system should be utilised and identity tags used to identify components.
4. Segregation means storing unserviceable components in a separate secured location from serviceable components.
5. Segregation and management of any unserviceable component should be ensured according to the pertinent procedure approved to that organisation.
6. Procedures should be defined by the organisation describing the decision process for the status of unserviceable components. This procedure should identify at least the following:
 - role and responsibilities of the persons managing the decision process;
 - description of the decision process to choose between maintaining, storing or mutilating a component;
 - traceability of decision
7. Once unserviceable components or materials have been identified as unsalvageable in accordance with M.A.501(a)(3) or MCAR-MLA.504(c), the organisation should establish secure areas in which to segregate such items and to prevent unauthorised access. Unsalvageable components should be managed through a procedure to ensure that these components receive the appropriate final disposal according to M.A.504 (b) or MCAR-MLA.504(d) or (e). The person responsible for the implementation of this procedure should be identified.

MCAR-M.A.606 Personnel requirements

- (a) The organisation shall appoint an accountable manager, who has corporate authority for ensuring that all maintenance required by the customer can be financed and carried out to the standard required by this Regulation.
- (b) A person or group of persons shall be nominated with the responsibility of ensuring that the organisation is always in compliance with this Subpart. Such person(s) shall be ultimately responsible to the accountable manager.
- (c) All point (b) persons shall be able to show relevant knowledge, background and appropriate experience related to aircraft and/or component maintenance.
- (d) The organisation shall have appropriate staff for the normal expected contracted work. The use of temporarily sub-contracted staff is permitted in the case of higher than normally expected contracted work and only for personnel not issuing a certificate of release to service.
- (e) The qualification of all personnel involved in maintenance, and airworthiness review shall be demonstrated and recorded.
- (f) Personnel who carry out specialised tasks such as welding, non-destructive testing/inspection other than colour contrast shall be qualified in accordance with an officially recognised standard.
- (g) The maintenance organisation shall have sufficient certifying staff to issue certificates of release to service for aircraft and components provided for in points M.A.612 and M.A.613. The staff shall comply with the following requirements:
 - 1. MCAR-66 in the case of aircraft;
 - 2. Has an certification authorisation issued in accordance with MCAR-145 or Section A Subpart F or MCAR-CAO, in the case of components.
- (h) By derogation from point (g), the organisation may use certifying staff qualified in accordance with the following provisions when providing maintenance support to operators involved in commercial operations, subject to appropriate procedures to be approved as part of the organisation's manual:
 - 1. For a repetitive pre-flight airworthiness directive which specifically states that the flight crew may carry out such airworthiness directive, the organisation may issue a limited certifying staff authorisation to the aircraft commander on the basis of the flight crew licence held, provided that the organisation ensures that sufficient practical training has been carried out to ensure that such person can accomplish the airworthiness directive to the required standard;
 - 2. In the case of aircraft operating away from a supported location the organisation may issue a limited certifying staff authorisation to the aircraft commander on the basis of the flight crew licence, provided that the organisation ensures that sufficient practical training has been carried out to ensure that such person can accomplish the task to the required standard.

- (i) If the organisation performs airworthiness reviews and issues the corresponding airworthiness review certificate for ELA1 aircraft not involved in commercial operations in accordance with ML.A.903 of MCAR-ML, it shall have airworthiness review staff qualified and authorised meeting all of the following requirements:
1. shall hold a certifying staff authorisation for the corresponding aircraft;
 2. shall have at least three years of experience as certifying staff;
 3. shall be independent from the continuing airworthiness management process of the aircraft being reviewed or shall have overall authority on the continuing airworthiness management process of the complete aircraft being reviewed;
 4. shall have acquired knowledge of Subpart C of this Regulation or Subpart C of MCAR-ML;
 5. shall have acquired proven knowledge of the procedures of the maintenance organisation relevant to the airworthiness review and issue of the airworthiness review certificate;
 6. shall have been formally accepted by the CAA after having performed an airworthiness review under the supervision of the CAA or under the supervision of the organisation's airworthiness review staff in accordance with a procedure approved by the CAA;
 7. shall have performed at least one airworthiness review in the last twelve-month period.

AMC M.A.606(a) Personnel requirements

With regard to the accountable manager, it is normally intended to mean the chief executive officer of the maintenance organisation approved under M.A. Subpart F, who by virtue of position has overall (including in particular financial) responsibility for running the organisation. The accountable manager may be the accountable manager for more than one organisation and is not required to be necessarily knowledgeable on technical matters. When the accountable manager is not the chief executive officer, the CAA will need to be assured that such an accountable manager has direct access to chief executive officer and has a sufficiency of maintenance funding allocation.

AMC M.A.606(b) Personnel requirements

1. Dependent upon the size of the organisation, the functions may be subdivided under individual managers or combined in any number of ways.
2. The maintenance organisation should have, dependent upon the extent of approval, an aircraft maintenance manager, a workshop manager all of whom should report to the accountable manager. In small maintenance organisations any manager may also be the accountable manager, and may also be the aircraft maintenance manager or the workshop manager.
3. The aircraft maintenance manager is responsible for ensuring that all maintenance required to be carried out, plus any defect rectification carried out during aircraft maintenance, is carried out to the design and quality standards specified in this Regulation. The aircraft maintenance manager is also responsible for any corrective action resulting from the M.A.616 organisational review.
4. The workshop manager is responsible for ensuring that all work on aircraft components is carried out to the standards specified in this Regulation and also responsible for any corrective action resulting from the M.A.616 organisational review.

5. Notwithstanding the example sub-paragraphs 2-4 titles, the organisation may adopt any title for the foregoing managerial positions but should identify to the CAA the titles and persons chosen to carry out these functions.

AMC M.A.606(c) Personnel requirements

1. All nominated persons should, in the normal way, be expected to satisfy the CAA that they possess the appropriate experience and qualifications which are listed in paragraphs 2.1 to 2.5 below.
2. All nominated persons should have:
 - 2.1 practical experience and expertise in the application of aviation safety standards and safe maintenance practices;
 - 2.2 comprehensive knowledge of:
 - (a) MCAR-M and MCAR-ML, as applicable, and any associated requirements and procedures;
 - (b) the maintenance organisation manual;
 - 2.3 five years aviation experience of which at least three years should be practical maintenance experience;
 - 2.4 knowledge of the relevant type(s) of aircraft or components maintained. This knowledge may be demonstrated by documented evidence or by an assessment performed by the CAA. This assessment should be recorded.

Training courses should be as a minimum at a level equivalent to MCAR-66 Appendix III Level 1 General Familiarisation, and could be imparted by a MCAR-147 organisation, by the manufacturer, or by any other organisation accepted by the CAA.

- 2.5 knowledge of maintenance standards.

AMC M.A.606(d) Personnel requirements

1. All staff are subjected to compliance with the organisation's procedures specified in the maintenance organisation manual relevant to their duties.
2. To have sufficient staff means that the approved maintenance organisation employs or contracts staff directly, even on a volunteer basis, for the anticipated maintenance workload.
3. Temporarily sub-contracted means the person is employed by another organisation and contracted by that organisation to the approved maintenance organisation.

AMC M.A.606(e) Personnel requirements

1. Personnel involved in maintenance should be assessed for competence by 'on the job' evaluation and/or by examination relevant to their particular job role within the organisation before unsupervised work is permitted.
2. Adequate initial and recurrent training should be provided and recorded to ensure continued competence.

AMC M.A.606(f) Personnel requirements

1. Non-destructive testing means such testing specified by the type certificate holder of the aircraft, engine or propeller in the M.A.401 (b) or ML.A.401(b) maintenance data for in service aircraft/aircraft components for the purpose of determining the continued fitness of the product to operate safely.
2. Appropriately qualified means to level 1, 2 or 3 as defined by European Standard EN 4179 (or equivalent) dependent upon the non-destructive testing function to be carried out.
3. Notwithstanding the fact that level 3 personnel may be qualified via EN 4179 (or equivalent) to establish and authorise methods, techniques, etc., this does not permit such personnel to deviate from methods and techniques published in the maintenance data, unless the maintenance data expressly permits such deviation.
4. Notwithstanding the general references in EN 4179 to a national aerospace NDT board, all examinations should be conducted by personnel or organisations under the general control of such a board. In the absence of a national aerospace NDT board, examinations should be conducted by personnel or organisations under the general control of the NDT board of a State acceptable to the CAA.
5. Particular non-destructive test means any one or more of the following: dye penetrant, magnetic particle, eddy current, ultrasonic and radiographic methods including X ray and gamma ray.
6. In addition it should be noted that new methods are and will be developed, such as, but not limited to thermography and shearography, which are not specifically addressed by EN 4179. Until such time as an agreed standard is established such methods should be carried out in accordance with the particular equipment manufacturers' recommendations including any training and examination process to ensure competence of the personnel with the process.
7. Any approved maintenance organisation that carries out continued airworthiness non-destructive testing should establish qualification procedures for non-destructive testing.
8. Boroscopy and other techniques such as delamination coin tapping are non-destructive inspections rather than non-destructive testing. Notwithstanding such differentiation, approved maintenance organisation should establish a procedure to ensure that personnel who carry out and interpret such inspections are properly trained and assessed for their competence with the process. Non-destructive inspections, not being considered as non-destructive testing by M.A.Subpart F are not listed in Appendix IV to MCAR-M under class rating D1.
9. The referenced standards, methods, training and procedures should be specified in the maintenance organisation manual.
10. Any such personnel who intend to carry out and/or control a non-destructive test for which they were not qualified prior to the effective date of MCAR-M should qualify for such non-destructive test in accordance with EN 4179 or equivalent.

In this context officially recognised standard means those standards established or published by an official body whether having legal personality or not, which are widely recognised by the air transport sector as constituting good practice.

AMC M.A.606(h)(2) Personnel requirements

1. For the issue of a limited certification authorisation the commander should hold either a valid air transport pilot license (ATPL), or commercial pilots license (CPL). In addition, the limited certification authorisation is subject to the maintenance organisation manual containing procedures to address the following:
 - (a) Completion of adequate airworthiness regulation training.
 - (b) Completion of adequate task training for the specific task on the aircraft. The task training should be of sufficient duration to ensure that the individual has a thorough understanding of the task to be completed and should involve training in the use of associated maintenance data.
 - (c) Completion of the procedural training.

The above procedures should be specified in the maintenance organisation manual and be accepted by the CAA.

2. Typical tasks that may be certified and/or carried out by the commander holding an ATPL or CPL are minor maintenance or simple checks included in the following list:
 - (a) Replacement of internal lights, filaments and flash tubes.
 - (b) Closing of cowlings and refitment of quick access inspection panels.
 - (c) Role changes, e.g., stretcher fit, dual controls, FLIR, doors, photographic equipment etc.
 - (d) Inspection for and removal of de-icing/anti-icing fluid residues, including removal/closure of panels, cowls or covers that are easily accessible but not requiring the use of special tools.
 - (e) Any check/replacement involving simple techniques consistent with this AMC and as agreed by the CAA.
3. The authorisation should have a finite life of twelve months subject to satisfactory recurrent training on the applicable aircraft type.

MCAR-M.A.607 Certifying staff and airworthiness review staff

- (a) In addition to point M.A.606(g), certifying staff can only exercise their privileges, if the organisation has ensured:
1. that certifying staff can demonstrate that they meet the requirements of MCAR-66.A.20(b), and;
 2. that certifying staff have an adequate understanding of the relevant aircraft and/or aircraft component(s) to be maintained together with the associated organisation procedures.
- (b) In the following unforeseen cases, where an aircraft is grounded at a location other than the main base where no appropriate certifying staff is available, the maintenance organisation contracted to provide maintenance support may issue a one-off certification authorisation:
1. to one of its employees holding type qualifications on aircraft of similar technology, construction and systems; or
 2. to any person with not less than three years maintenance experience and holding a valid ICAO aircraft maintenance licence rated for the aircraft type requiring certification provided there is no organisation appropriately approved under this Regulation at that location and the contracted organisation obtains and holds on file evidence of the experience and the licence of that person.

All such cases must be reported to the CAA within seven days after issuing such certification authorisation. The approved maintenance organisation issuing the one-off certification authorisation shall ensure that any such maintenance that could affect flight safety is re-checked.

- (c) The approved maintenance organisation shall record all details concerning certifying staff and airworthiness review staff and maintain a current list of all certifying staff and airworthiness review staff together with their scope of approval as part of the organisation's manual pursuant to point M.A.604(a)5.

AMC M.A.607 Certifying staff and airworthiness review staff

1. Adequate understanding of the relevant aircraft and/or aircraft component(s) to be maintained together with the associated organisation procedures means that the person has received training and has relevant maintenance experience on the product type and associated organisation procedures such that the person understands how the product functions, what are the more common defects with associated consequences.
2. All prospective certifying staff are required to be assessed for competence, qualification and capability related to intended certifying duties. Competence and capability can be assessed by having the person work under the supervision of another certifying person for sufficient time to arrive at a conclusion. Sufficient time could be as little as a few weeks if the person is fully exposed to relevant work. The person need not be assessed against the complete spectrum of intended duties. When the person has been recruited from another approved maintenance organisation and was a certifying person in that organisation then it is reasonable to accept a written confirmation from the previous organisation.
3. The organisation should hold copies of all documents that attest to qualification, and to recent experience.

AMC M.A.607(c) Certifying staff and airworthiness review staff

1. The following minimum information as applicable should be kept on record in respect of each certifying person:
 - (a) name;
 - (b) date of birth;
 - (c) basic training;
 - (d) type training;
 - (e) recurrent training;
 - (f) specialised training;
 - (g) experience;
 - (h) qualifications relevant to the approval;
 - (i) scope of the authorisation and personal authorisation reference;
 - (j) date of first issue of the authorisation;
 - (k) if appropriate – expiry date of the authorisation.
2. The following minimum information, as applicable, should be kept on record in respect of each airworthiness review person:
 - (a) name;
 - (b) date of birth;
 - (c) certifying staff authorisation;
 - (d) experience as certifying staff on ELA1 aircraft;
 - (e) qualifications relevant to the approval (knowledge of relevant parts of MCAR-ML and knowledge of the relevant airworthiness review procedures);
 - (f) scope of the airworthiness review authorisation and personal authorisation reference;
 - (g) date of first issue of the airworthiness review authorisation; and
 - (h) if appropriate, expiry date of the airworthiness review authorisation.
3. Persons authorised to access the system should be maintained at a minimum to ensure that records cannot be altered in an unauthorised manner or that such confidential records become accessible to unauthorised persons.
4. The CAA should be granted access to the records upon request.

MCAR-M.A.608 Components, equipment and tools

- (a) The organisation shall:
1. hold the equipment and tools specified in the maintenance data described in point M.A.609 or verified equivalents as listed in the maintenance organisation manual as necessary for day-to-day maintenance within the scope of the approval; and,
 2. demonstrate that it has access to all other equipment and tools used only on an occasional basis.
- (b) Tools and equipment shall be controlled and calibrated to an officially recognised standard. Records of such calibrations and the standard used shall be kept by the organisation.
- (c) The organisation shall inspect, classify and appropriately segregate all incoming components, standard parts and materials.

AMC M.A.608(a) Components, equipment and tools

1. Once the applicant for M.A. Subpart F approval has determined the intended scope of approval for consideration by the CAA, it will be necessary to show that all tools and equipment as specified in the maintenance data can be made available when needed.
2. All such tools should be clearly identified and listed in a control register including any personal tools and equipment that the organisation agrees can be used.
3. For tools required on an occasional basis, the organisation should ensure that they are controlled in terms of servicing or calibration as required.

AMC M.A.608(b) Components, equipment and tools

1. The control of these tools and equipment requires that the organisation has a procedure to inspect/service and, where appropriate, calibrate such items on a regular basis and indicate to users that the item is within any inspection or service or calibration time-limit. A clear system of labelling all tooling, equipment and test equipment is therefore necessary giving information on when the next inspection or service or calibration is due and if the item is unserviceable for any other reason where it may not be obvious. A register should be maintained for all the organisation's precision tooling and equipment together with a record of calibrations and standards used.
2. Inspection, service or calibration on a regular basis should be in accordance with the equipment manufacturers' instructions except where the M.A. Subpart F organisation can show by results that a different time period is appropriate in a particular case.
3. In this context officially recognised standard means those standards established or published by an official body whether having legal personality or not, which are widely recognised by the air transport sector as constituting good practice.

MCAR-M.A.609 Maintenance data

The approved maintenance organisation shall hold and use applicable current maintenance data specified in M.A.401 or in MCAR-ML.A.401, as applicable, in the performance of maintenance including modifications and repairs. However, In the case of customer provided maintenance data, the organisation shall only hold and use such data when the maintenance work is in progress.

AMC M.A.609 Maintenance data

When an organisation uses customer provided maintenance data, the scope of approval indicated in the maintenance organisation manual should be limited to the individual aircraft covered by the contracts signed with those customers unless the organisation also holds its own complete set of maintenance data for that type of aircraft.

MCAR-M.A.610 Maintenance work orders

Before the commencement of maintenance a written work order shall be agreed between the organisation and the organisation requesting maintenance to clearly establish the maintenance to be carried out.

AMC M.A.610 Maintenance work orders

'A written work order' may take the form of, but not limited to, the following:

- A formal document or form specifying the work to be carried out. This form may be provided by the continuing airworthiness management organisation managing the aircraft, or by the maintenance organisation undertaking the work, or by the owner/operator himself;
- An entry in the aircraft log book specifying the defect that needs to be corrected.

MCAR-M.A.611 Maintenance standards

All maintenance shall be carried out in accordance with the requirements of M.A. Subpart D or with the requirements of Section A Subpart D of MCAR-ML.

MCAR-M.A.612 Aircraft certificate of release to service

Upon completion of all required aircraft maintenance in accordance with this Subpart an aircraft CRS shall be issued in accordance with point M.A.801 or MCAR-ML.A.801.

MCAR-M.A.613 Component certificate of release to service

- (a) Upon completion of all required component maintenance in accordance with this Subpart, a component CRS shall be issued in accordance with M.A.802 or MCAR-ML.A.802, as applicable. CAA Form 1 shall be issued except for those components maintained in accordance with (b) or (d) of point M.A.502, for components fabricated in accordance with M.A.603(c) and for components in respect of which point MCAR-ML.A.502 provides otherwise.
- (b) The component CRS document, CAA Form 1 may be generated from a computer system.

AMC M.A.613(a) Component certificate of release to service

1. An aircraft component which has been maintained off the aircraft requires the issuance of a CRS for such maintenance and another CRS in regard to being installed properly on the aircraft when such action occurs. When an organisation maintains a component for use by the same organisation, a CAA Form 1 may not be necessary depending upon the organisation's internal release procedures defined in the maintenance organisation exposition.
2. In the case of components in storage prior to MCAR-145, MCAR-M and MCAR-21 and not released on a CAA Form 1 or equivalent in accordance with M.A.501(a) or removed serviceable from a serviceable aircraft which have been withdrawn from service, this paragraph provides additional guidance regarding the conditions under which an CAA Form 1 may be issued.
 - 2.1 A CAA Form 1 may be issued for an aircraft component which has been:
 - Maintained before MCAR-145, or MCAR-M became effective or manufactured before MCAR-21 became effective.
 - Used on an aircraft and removed in a serviceable condition. Examples include leased and loaned aircraft components.
 - Removed from aircraft which have been withdrawn from service, or from aircraft which have been involved in abnormal occurrences such as accidents, incidents, heavy landings or lightning strikes.
 - Components maintained by an unapproved organisation.
 - 2.2 An appropriately rated M.A Subpart F maintenance organisation may issue a CAA Form 1 as detailed in this AMC subparagraph 2.5 to 2.9, as appropriate, in accordance with the procedures detailed in the manual as approved by the CAA. The appropriately rated M.A Subpart F maintenance organisation is responsible for ensuring that all reasonable measures have been taken to ensure that only approved and serviceable aircraft components are issued a CAA Form 1 under this paragraph.
 - 2.3 For the purposes of this paragraph 2 only, 'appropriately rated' means an organisation with an approval class rating for the type of component or for the product in which it may be installed.
 - 2.4 A CAA Form 1 issued in accordance with this paragraph 2 should be issued by signing in block 14b and stating 'Inspected/Tested' in block 11. In addition, block 12 should specify:
 - 2.4.1 when the last maintenance was carried out and by whom;
 - 2.4.2 if the component is unused, when the component was manufactured and by whom with a cross-reference to any original documentation which should be included with the Form;
 - 2.4.3 a list of all ADs, repairs and modifications known to have been incorporated. If no ADs or repairs or modifications are known to be incorporated then this should be so stated;

- 2.4.4 detail of life used for service life-limited parts and time-controlled components being any combination of fatigue, overhaul or storage life;
- 2.4.5 for any aircraft component having its own maintenance history record, reference to the particular maintenance history record as long as the record contains the details that would otherwise be required in block 12. The maintenance history record and acceptance test report or statement, if applicable, should be attached to the CAA Form 1.

2.5 New/unused aircraft components

- 2.5.1 Any unused aircraft component in storage without a CAA Form 1 up to the effective date(s) for MCAR-21 that was manufactured by an organisation acceptable to the CAA at the time may be issued a CAA Form 1 by an appropriately rated maintenance organisation approved under M.A Subpart F. The CAA Form 1 should be issued in accordance with the following subparagraphs which should be included in a procedure within the maintenance organisation manual.

Note 1: It should be understood that the release of a stored but unused aircraft component in accordance with this paragraph represents a maintenance release under M.A Subpart F and not a production release under MCAR-21. It is not intended to bypass the production release procedure agreed by the State of Design for parts and subassemblies intended for fitment on the manufacturers own production line.

- (a) An acceptance test report or statement should be available for all used and unused aircraft components that are subject to acceptance testing after manufacturing or maintenance as appropriate.
 - (b) The aircraft component should be inspected for compliance with the manufacturer's instructions and limitations for storage and condition including any requirement for limited storage life, inhibitors, controlled climate and special storage containers. In addition, or in the absence of specific storage instructions, the aircraft component should be inspected for damage, corrosion and leakage to ensure good condition.
 - (c) The storage life used of any storage life-limited parts should be established.
- 2.5.2 If it is not possible to establish satisfactory compliance with all applicable conditions specified in subparagraph 2.5.1 (a) to (c) inclusive, the aircraft component should be disassembled by an appropriately rated organisation and subjected to a check for incorporated ADs, repairs and modifications and inspected/ tested in accordance with the maintenance data to establish satisfactory condition and, if relevant, all seals, lubricants and life-limited parts replaced. Upon satisfactory completion after reassembly, a CAA Form 1 may be issued stating what was carried out and the reference to the maintenance data included.

2.6 Used aircraft components removed from a serviceable aircraft.

2.6.1 Serviceable aircraft components removed from a Maldivian registered aircraft may be issued a CAA Form 1 by an appropriately rated organisation subject to compliance with this subparagraph.

- (a) The organisation should ensure that the component was removed from the aircraft by an appropriately qualified person.
- (b) The aircraft component may only be deemed serviceable if the last flight operation with the component fitted revealed no faults on that component or related system.
- (c) The aircraft component should be inspected for satisfactory condition including in particular damage, corrosion or leakage and compliance with any additional maintenance data.
- (d) The aircraft record should be researched for any unusual events that could affect the serviceability of the aircraft component such as involvement in accidents, incidents, heavy landings or lightning strikes. Under no circumstances may a CAA Form 1 be issued in accordance with this paragraph 2.6 if it is suspected that the aircraft component has been subjected to extremes of stress, temperatures or immersion which could affect its operation.
- (e) A maintenance history record should be available for all used serialised aircraft components.
- (f) Compliance with known modifications and repairs should be established.
- (g) The flight hours/cycles/landings as applicable of any life-limited parts and time-controlled components including time since overhaul should be established.
- (h) Compliance with known applicable airworthiness directives should be established.
- (i) Subject to satisfactory compliance with this subparagraph 2.6.1, a CAA Form 1 may be issued and should contain the information as specified in paragraph 2.4 including the aircraft from which the aircraft component was removed.

2.6.2 Serviceable aircraft components removed from an aircraft not registered in the Maldives may only be issued a CAA Form 1 if the components are leased or loaned from the maintenance organisation approved under M.A Subpart F who retains control of the airworthiness status of the components. A CAA Form 1 may be issued and should contain the information as specified in paragraph 2.4 including the aircraft from which the aircraft component was removed.

- 2.7 Used aircraft components removed from an aircraft withdrawn from service. Serviceable aircraft components removed from a Maldivian registered aircraft withdrawn from service may be issued a CAA Form 1 by a maintenance organisation approved under M.A.Subpart F subject to compliance with this subparagraph.
- (a) Aircraft withdrawn from service are sometimes dismantled for spares. This is considered to be a maintenance activity and should be accomplished under the control of an organisation approved under M.A. Subpart F, employing procedures approved by the CAA.
 - (b) To be eligible for installation, components removed from such aircraft may be issued with a CAA Form 1 by an appropriately rated organisation following a satisfactory assessment.
 - (c) As a minimum, the assessment will need to satisfy the standards set out in paragraphs 2.5 and 2.6 as appropriate. This should, where known, include the possible need for the alignment of scheduled maintenance that may be necessary to comply with the maintenance programme applicable to the aircraft on which the component is to be installed.
 - (d) Irrespective of whether the aircraft holds a certificate of airworthiness or not, the organisation responsible for certifying any removed component should satisfy itself that the manner in which the components were removed and stored are compatible with the standards required by M.A Subpart F.
 - (e) A structured plan should be formulated to control the aircraft disassembly process. The disassembly is to be carried out by an appropriately rated organisation under the supervision of certifying staff, who will ensure that the aircraft components are removed and documented in a structured manner in accordance with the appropriate maintenance data and disassembly plan.
 - (f) All recorded aircraft defects should be reviewed and the possible effects these may have on both normal and standby functions of removed components are to be considered.
 - (g) Dedicated control documentation is to be used as detailed by the disassembly plan, to facilitate the recording of all maintenance actions and component removals performed during the disassembly process. Components found to be unserviceable are to be identified as such and quarantined pending a decision on the actions to be taken. Records of the maintenance accomplished to establish serviceability are to form part of the component maintenance history.
 - (h) Suitable M.A Subpart F facilities for the removal and storage of removed components are to be used which include suitable environmental conditions, lighting, access equipment, aircraft tooling and storage facilities for the work to be undertaken. While it may be acceptable for components to be removed, given local environmental conditions, without the benefit of an enclosed facility subsequent disassembly (if required) and storage of the components should be in accordance with the manufacturer's recommendations.

- 2.8 Used aircraft components maintained by organisations not approved in accordance with M.A Subpart F, MCAR-145 or MCAR-CAO.

For used components maintained by a maintenance organisation not approved under M.A. Subpart F or MCAR-145, due care should be taken before acceptance of such components. In such cases an appropriately rated maintenance organisation approved under M.A Subpart F should establish satisfactory conditions by:

- (a) dismantling the component for sufficient inspection in accordance with the appropriate maintenance data,
- (b) replacing of all life-limited components and time-controlled components when no satisfactory evidence of life used is available and/or the components are in an unsatisfactory condition,
- (c) reassembling and testing as necessary the component,
- (d) completing all certification requirements as specified in M.A.613.

In the case of used components maintained by an EASA Part-145 or EASA M.A. Subpart F organisation or EASA Part-CAO organisation, FAA Part-145 repair station (USA) or by TCCA CAR573 approved maintenance organisations (Canada) that does not hold a CAA MCAR-145 or M.A. Subpart F approval, the conditions (a) through (d) described above may be replaced by the following conditions:

- (a) availability of an EASA Form 1, an FAA 8130-3 or Transport Canada TCAA 24-0078 / Authorised Release Certificate Form One,
- (b) verification of compliance with all applicable airworthiness directives, and
- (c) verification that the component does not contain repairs or modifications that have not been approved in accordance with MCAR-21,
- (d) inspection for satisfactory condition including in particular damage, corrosion or leakage,
- (e) issuance of a CAA Form 1 in compliance with paragraphs 2.2, 2.3 and 2.4.

- 2.9 Used aircraft components removed from an aircraft involved in an accident or incident. Such components should only be issued with an CAA Form 1 when processed in accordance with paragraph 2.7 and a specific work order including all additional necessary tests and inspections made necessary by the accident or incident. Such a work order may require input from the TC holder or original manufacturer as appropriate. This work order should be referenced in block 12.

3. A certificate should not be issued for any component when it is known that the component is unserviceable except in the case of a component undergoing a series of maintenance processes at several approved maintenance organisations and the component needs a certificate for the previous maintenance process carried out for the next approved maintenance organisation to accept the component for subsequent maintenance processes. In such a case, a clear statement of limitation should be endorsed in block 12.

4. The certificate is to be used for export/import purposes, as well as for domestic purposes, and serves as an official certificate for components from the manufacturer/maintenance organisation to users. It should only be issued by organisations approved by the CAA within the scope of the approval.

MCAR-M.A.614 Maintenance and airworthiness review records

- (a) The approved maintenance organisation shall record all details of work carried out. Records necessary to prove all requirements have been met for the issue of the certificate of release to service including the sub-contractor's release documents and for the issue of any airworthiness review certificate shall be retained.
- (b) The approved maintenance organisation shall provide a copy of each CRS to the aircraft owner or operator, together with a copy of any detailed maintenance records associated with the work carried out and necessary to demonstrate compliance with point M.A.305 or MCAR-ML.A.305, as applicable.
- (c) The approved maintenance organisation shall retain a copy of all maintenance records and any associated maintenance data for three years from the date the aircraft or aircraft component to which the work relates was released from the approved maintenance organisation. In addition, it shall retain a copy of all the records related to the issue of airworthiness review certificates for three years from the date of issue and shall provide a copy of them to the owner of the aircraft.
 1. The records under this point shall be stored in a manner that ensures protection from damage, alteration and theft.
 2. All computer hardware used to ensure backup shall be stored in a different location from that containing the working data in an environment that ensures they remain in good condition.
 3. Where an approved maintenance organisation terminates its operation, all retained maintenance records covering the last three years shall be distributed to the last owner or customer of the respective aircraft or component or shall be stored as specified by the CAA.

AMC M.A.614(a) Maintenance and airworthiness review records

1. Properly executed and retained records provide owners, operators and maintenance personnel with information essential in controlling unscheduled and scheduled maintenance, and troubleshooting to eliminate the need for re-inspection and rework to establish airworthiness.
2. The prime objective is to have secure and easily retrievable records with comprehensive and legible contents. The aircraft record should contain basic details of all serialised aircraft components and all other significant aircraft components installed, to ensure traceability to such installed aircraft component documentation, associated maintenance data and data for modifications and repairs.
3. The maintenance record can be either a paper or computer system or any combination of both. The records should remain legible throughout the required retention period.
4. Paper systems should use robust material which can withstand normal handling and filing.
5. Computer systems may be used to control maintenance and/or record details of maintenance work carried out. Computer systems used for maintenance should have at least one backup system which should be updated at least within 24 hours of any maintenance. Each terminal is required to contain programme safeguards against the ability of unauthorised personnel to alter the database.

AMC M.A.614(c) Maintenance and airworthiness review records

Associated maintenance data is specific information such as repair and modification data. This does not necessarily require the retention of all aircraft maintenance manual, component maintenance manual, parts catalogues etc. issued by the TC holder or STC holder. Maintenance records should refer to the revision status of the data used.

MCAR-M.A.615 Privileges of the organisation

The maintenance organisation approved in accordance with Section A, Subpart F of this Regulation, may:

- (a) maintain any aircraft and/or component for which it is approved at the locations specified in the approval certificate and the maintenance organisation manual;
- (b) arrange for the performance of specialised services under the control of the maintenance organisation at another organisation appropriately qualified, as described in the maintenance organisation manual;
- (c) maintain any aircraft or component for which it is approved at any location, where the need of such maintenance arises either from the unserviceability of the aircraft or from the necessity of supporting occasional maintenance and subject to compliance with the conditions specified in the Maintenance Organisation Manual;
- (d) issue certificates of release to service, upon completion of maintenance, in accordance with point M.A.612 or point M.A.613 of this Regulation.
- (e) If specifically approved to do so for ELA1 aircraft not involved in commercial operations, perform airworthiness reviews and issue the corresponding airworthiness review certificate in accordance with the conditions specified in point MCAR-ML.A.903.

The organisation shall only maintain an aircraft or component for which it is approved when all the necessary facilities, equipment, tooling, material, maintenance data and certifying staff are available.

GM M.A.615 Privileges of the organisation

M.A.615 states that the organisation shall only maintain an aircraft or component for which it is approved when all the necessary facilities, equipment, tooling, material, maintenance data, and certifying staff are available.

This provision is intended to cover the situation where the larger organisation may temporarily not hold all the necessary tools, equipment, etc. for an aircraft type or variant specified in the organisation's approval. This paragraph means that the CAA need not amend the approval to delete the aircraft type or variants on the basis that it is a temporary situation and there is a commitment from the organisation to re-acquire tools, equipment, etc. before maintenance on the type may recommence.

GM M.A.615(a) Privileges of the organisation

M.A.615(a) applies also to facilities which may not be individually approved by the CAA, such as those described in AMC M.A.605(a) for ELA2 aircraft.

AMC M.A.615(b) Privileges of the organisation

M.A.615(b) refers to work carried out by another organisation which is not appropriately approved under M.A. Subpart F, MCAR-145 or MCAR-CAO to carry out such tasks.

The intent is to permit the acceptance of specialised maintenance services, such as, but not limited to, non-destructive testing, surface treatment, heat-treatment, welding, fabrication of specified parts for minor repairs and modifications, etc., without the need of M.A. Subpart F approval for those tasks.

The requirement that the organisation performing the specialised services must be “appropriately qualified” means that it should meet an officially recognised standard or, otherwise, it should be acceptable to the CAA (through the approval of the Maintenance Organisation Manual).

“Under the control of the M.A. Subpart F organisation” means that the M.A. Subpart F organisation should investigate the capability of the subcontracted organisation (including qualifications, facilities, equipment and materials) and ensure that such organisation:

- Receives appropriate maintenance instructions and maintenance data for the task to be performed.
- Properly records the maintenance performed in the Subpart F airworthiness records.
- Notifies the M.A. Subpart F organisation for any deviation or non-conformity, which has arisen during such maintenance.

The CRS may be issued either at the subcontractors or at the organisation facility by authorised certifying staff, and always under the M.A. Subpart F organisation reference. Such staff would normally come from the M.A. Subpart F organisation but may otherwise be a person from the subcontractor who meets the M.A. Subpart F organisation certifying staff standard which itself is approved by the CAA via the Maintenance Organisation Manual.

Subcontracted specialised services organisations should be listed in the Maintenance Organisation Manual of the M.A. Subpart F organisation together with their qualifications, and the associated control procedures.

MCAR-M.A.616 Organisational review

To ensure that the approved maintenance organisation continues to meet the requirements of this Subpart, it shall organise, on a regular basis, organisational reviews.

AMC M.A.616 Organisational review

1. The primary objectives of the organisational review are to enable the approved maintenance organisation to ensure that it can deliver a safe product and that approved maintenance organisation remains in compliance with the requirements.
2. The approved maintenance organisation should identify:
 - 2.1 The person responsible for the organisational review;
 - 2.2 The frequency of the reviews;
 - 2.3 The scope and content of the reviews;

- 2.4 The persons accomplishing the reviews;
 - 2.5 The procedure for planning, performing and processing review findings; and
 - 2.6 The procedure for ensuring corrective actions are carried out in the appropriate time frame.
3. The organisation quality system as specified in MCAR-145 provides an acceptable basic structure for the organisational review system for organisations with more than 10 maintenance staff, dependent upon the complexity of the organisation.
 4. Appendix VIII to AMC M.A.616 should be used to manage the organisational reviews.

MCAR-M.A.617 Changes to the approved maintenance organisation

In order to enable the CAA to determine continued compliance with this Regulation, the approved maintenance organisation shall notify it of any proposal to carry out any of the following changes, before such changes take place:

1. the name of the organisation;
2. the location of the organisation;
3. additional locations of the organisation;
4. the accountable manager;
5. any of the persons specified in point M.A.606(b);
6. the facilities, equipment, tools, material, procedures, work scope, certifying staff and airworthiness review staff that could affect the approval.

In the case of proposed changes in personnel not known to the management beforehand, these changes shall be notified at the earliest opportunity.

AMC M.A.617 Changes to the approved maintenance organisation

The CAA should be given adequate notification of any proposed changes in order to enable the maintenance organisation to remain approved if agreed by the CAA during negotiations about any of the specified changes. Without this paragraph the approval would automatically be suspended in all cases.

MCAR-M.A.618 **Continued validity of approval**

- (a) An approval shall remain valid until 01 May 2023, subject to:
1. the organisation remaining in compliance with this Regulation, in accordance with the provisions related to the handling of findings as specified under point M.A.619, and;
 2. the CAA being granted access to the organisation to determine continued compliance with this Regulation, and;
 3. the approval not being surrendered or revoked;
- (b) Upon surrender or revocation, the approval certificate shall be returned to the CAA.

MCAR-M.A.619 **Findings**

- (a) A level 1 finding is any finding of significant non-compliance with the requirements of this Regulation and MCAR-ML which lowers the safety standard and seriously endangers flight safety.
- (b) A level 2 finding is any finding of non-compliance with the requirements of this Regulation and MCAR-ML which may lower the safety standard and may endanger flight safety.
- (c) After receipt of notification of findings according to point M.B.605, the holder of the maintenance organisation approval shall define a corrective action plan and demonstrate corrective action to the satisfaction of the CAA within a period agreed with this authority.

Subpart G — CONTINUING AIRWORTHINESS MANAGEMENT ORGANISATION

MCAR-M.A.701 Scope

This Subpart establishes the requirements to be met by an organisation to qualify for the issue or continuation of an approval for the management of aircraft continuing airworthiness.

MCAR-M.A.702 Application

An application for issue or change of a continuing airworthiness management organisation approval shall be made on a form and in a manner established by the CAA.

AMC M.A.702 Application

An application should be made on a CAA Form 2 (Appendix IX to AMC M.A.602 and AMC M.A.702) or equivalent acceptable to the CAA.

CAA Form 2 is valid for the application for M.A. Subpart F, MCAR-CAO, MCAR-CAMO, MCAR-145 and M.A. Subpart G organisations. Organisations applying for several approvals may do so using a single CAA Form 2.

MCAR-M.A.703 Extent of approval

- (a) The approval is indicated on a certificate included in Appendix VI issued by the CAA.
- (b) Notwithstanding point (a), for licenced air carriers, the approval shall be part of the air operator certificate issued by the CAA, for the aircraft operated.
- (c) The scope of work deemed to constitute the approval shall be specified in the continuing airworthiness management exposition in accordance with point M.A.704.

MCAR-M.A.704 Continuing airworthiness management exposition

- (a) The continuing airworthiness management organisation shall provide a continuing airworthiness management exposition containing the following information:
 - 1. a statement signed by the accountable manager to confirm that the organisation will at all times work in accordance with this Regulation and MCAR-ML, as applicable;
 - 2. the organisation's scope of work, and;
 - 3. the title(s) and name(s) of person(s) referred to in points M.A.706(a), M.A.706(c), M.A.706(d) and M.A.706(i), and;
 - 4. an organisation chart showing associated chains of responsibility between all the person(s) referred to in points M.A.706(a), M.A.706(c), M.A.706(d) and M.A.706(i), and;
 - 5. a list of the airworthiness staff referred to in point M.A.707, specifying, where applicable, the staff authorised to issue permits to fly in accordance with point M.A.711(c), and;

6. a general description and location of the facilities, and;
 7. the procedures specifying how the organisation ensures compliance with this Regulation and MCAR-ML, as applicable and;
 8. the continuing airworthiness management exposition amendment procedures, and;
 9. the list of approved aircraft maintenance programmes, or, for aircraft not used by licenced air carriers, the list of “generic” and “baseline” maintenance programmes.
- (b) The continuing airworthiness management exposition and its amendments shall be approved by the CAA.
- (c) Notwithstanding point (b), minor amendments to the exposition may be approved indirectly through an indirect approval procedure. The indirect approval procedure shall define the minor amendment eligible, be established by the continuing airworthiness management organisation as part of the exposition and be approved by the CAA.

AMC1 M.A.704 Continuing airworthiness management exposition

1. The purpose of the continuing airworthiness management exposition is to set forth the procedures, means and methods of the CAMO. Compliance with its contents will assure compliance with MCAR-M and, as applicable, MCAR-ML requirements.
2. A continuing airworthiness management exposition should comprise:
 - Part 0 General organisation
 - Part 1 Continuing airworthiness procedures
 - Part 2 Quality system or organisational review (as applicable)
 - Part 3 Contracted maintenance – management of maintenance (liaison with maintenance organisations)
 - Part 4 Airworthiness review procedures (if applicable)
3. Personnel should be familiar with those parts of the continuing airworthiness management exposition that are relevant to their tasks.
4. The CAMO should specify in the exposition who is responsible for the amendment of the document. Unless otherwise agreed by the CAA, the person responsible for the management of the quality system or for the organisational review should be responsible for monitoring and amending the continuing airworthiness management exposition, including associated procedure’s manuals, and the submission of proposed amendments to the CAA. The CAA may agree to a procedure, and its agreement will be stated in the amendment control section of the continuing airworthiness management exposition defining the of class amendments, which can be incorporated without the prior consent of the CAA (“indirect approval procedure”).
5. The CAMO may use electronic data processing (EDP) for the publication of the continuing airworthiness management exposition. The continuing airworthiness management exposition should be made available to the CAA in a form acceptable to the latter. Attention should be paid to the compatibility of the EDP publication systems with the necessary dissemination, both internally and externally, of the continuing airworthiness management exposition.

6. The continuing airworthiness management exposition should contain information, as applicable, on how the CAMO complies with CDCCL instructions.
7. Appendix V to AMC1 M.A.704 contains an example of a continuing airworthiness management exposition layout.

AMC2 M.A.704 Continuing airworthiness management exposition

EXPOSITION LAYOUT FOR A CAMO HOLDING A MAINTENANCE ORGANISATION APPROVAL

1. Where a CAMO is also approved to another Regulation, the exposition or manual required by the other Regulation may form the basis of the continuing airworthiness management exposition in a combined document.
2. Example for a combined CAMO and MCAR-145 organisation:

MCAR-145 Exposition (see equivalent paragraphs in AMC 145.A.70 (a))

Part 0 General organisation

Part 1 Management

Part 2 Maintenance procedures

Part L2 Additional line maintenance procedures

Part 3 Quality system and/or organisational review (as applicable)

This chapter should cover the functions specified in M.A.712 "Quality system" and 145.A.65 "Safety and quality system"

Part 4 Contracts

This chapter should include:

- the contracts of the CAMO with the owner/operators as per Appendix I to MCAR-M or Appendix I to MCAR-ML*
- the CAMO procedures for the management of maintenance and liaison with maintenance organisations.*

Part 5 Appendices (sample of documents)

Part 6 Continuing airworthiness management procedures

Part 7 FAA supplement (if applicable)

Part 8 TCCA supplement (if applicable)

Part 9 Airworthiness review procedures (if applicable)

3. Example for a combined CAMO and M.A. Subpart F organisation:

Part 0 General organisation

Part 1 General

Part 2 Description

Part 3 General Procedures

Part 4 Working Procedures.

This Part should contain, among other things, procedures for quality system or organisational review, as applicable.

Part 5 Appendices

Part 6 Continuing airworthiness management procedures

Part 7 Airworthiness review procedures (if applicable)

AMC M.A.704(a)(1) Continuing airworthiness management exposition

1. Part 0 “General organisation” of the continuing airworthiness management exposition should include a corporate commitment by the CAMO, signed by the accountable manager, confirming that the continuing airworthiness management exposition and any associated manuals define the organisation’s compliance with this Regulation and, as applicable, with MCAR-ML and will be complied with at all times.
2. The accountable manager’s exposition statement should embrace the intent of the following paragraph, and in fact this statement may be used without amendment. Any amendment to the statement should not alter its intent.

“This exposition defines the organisation and procedures upon which the Maldives Civil Aviation Authority CAMO approval is based.

These procedures are approved by the undersigned and should be complied with, as applicable, in order to ensure that all continuing airworthiness tasks are carried out on time to an approved standard.

It is accepted that these procedures do not override the necessity of complying with any new or amended regulation published from time to time where these new or amended regulations are in conflict with these procedures.

It is understood that the CAA will approve this organisation whilst the CAA is satisfied that the procedures are being followed and the work standard is maintained. It is understood that the CAA reserves the right to suspend, limit or revoke the CAMO approval or the air operator certificate, as applicable, if the CAA has evidence that the procedures are not followed and the standards not upheld.

*Signed.....
Dated.....
Accountable Manager and... (quote position)...
For and on behalf of... (quote organisation’s name)...”*

3. Whenever the accountable manager is changed it is important to ensure that the new accountable manager signs the paragraph 2 statement at the earliest opportunity as part of the acceptance by the CAA. Failure to carry out this action invalidates the CAMO approval or the air operator certificate.

MCAR-M.A.705 Facilities

The continuing airworthiness management organisation shall provide suitable office accommodation at appropriate locations for the personnel specified in M.A.706.

AMC M.A.705 Facilities

Office accommodation should be such that the incumbents, whether they be continuing airworthiness management, planning, technical records or quality staff, can carry out their designated tasks in a manner that contributes to good standards. In the smaller CAMO, the CAA may agree to these tasks being conducted from one office subject to being satisfied that there is sufficient space and that each task can be carried out without undue disturbance. Office accommodation should also include an adequate technical library and room for document consultation.

MCAR-M.A.706 Personnel requirements

- (a) The organisation shall appoint an accountable manager, who has corporate authority for ensuring that all continuing airworthiness management activities can be financed and carried out in accordance with this Regulation and MCAR-ML, as applicable.
- (b) For licenced air carriers the accountable manager referred to in point (a) shall be the person who also has corporate authority for ensuring that all the operations of the operator can be financed and carried out to the standard required for the issue of an air operator's certificate.
- (c) A person or group of persons shall be nominated with the responsibility of ensuring that the organisation always complies with the applicable continuing airworthiness management, airworthiness review and permit to fly requirements of this Regulation and MCAR-ML. Such person(s) shall be ultimately responsible to the accountable manager.
- (d) For licenced air carriers, the accountable manager shall designate a nominated post holder. This person shall be responsible for the management and supervision of continuing airworthiness activities, pursuant to paragraph (c).
- (e) The nominated post holder referred to in point (d) shall not be employed by a MCAR-145 approved organisation under contract to the operator, unless specifically agreed by the CAA.
- (f) The organisation shall have sufficient appropriately qualified staff for the expected work.
- (g) All point (c) and (d) persons shall be able to show relevant knowledge, background and appropriate experience related to aircraft continuing airworthiness.
- (h) The qualification of all personnel involved in continuing airworthiness management shall be recorded.
- (i) For organisations extending airworthiness review certificates in accordance with points M.A.711(a)4 and M.A.901 of this Regulation or point ML.A.901(c) of MCAR-ML as applicable, the organisation shall nominate persons authorised to do so, subject to approval by the CAA.
- (j) The organisation shall define and keep updated in the continuing airworthiness management exposition the title(s) and name(s) of person(s) referred to in points M.A.706(a), M.A.706(c), M.A.706(d) and M.A.706(i).
- (k) For complex motor-powered aircraft and for aircraft used by licenced air carriers, the organisation shall establish and control the competence of personnel involved in the continuing airworthiness management, airworthiness review and/or quality audits in accordance with a procedure and to a standard agreed by the CAA.

AMC M.A.706 Personnel requirements

1. The person or group of persons should represent the continuing airworthiness management structure of the organisation and be responsible for all continuing airworthiness functions. Dependent on the size of the operation and the organisational set-up, the continuing airworthiness functions may be divided under individual managers or combined in nearly any number of ways. However, if a quality system is in place it should be independent from the other functions.

2. The actual number of persons to be employed and their necessary qualifications is dependent upon the tasks to be performed and thus dependent on the size and complexity of the organisation (general aviation aircraft, corporate aircraft, number of aircraft and the aircraft types, complexity of the aircraft and their age and for commercial air transport, route network, line or charter, ETOPS) and the amount and complexity of maintenance contracting. Consequently, the number of persons needed, and their qualifications may differ greatly from one organisation to another and a simple formula covering the whole range of possibilities is not feasible.
3. To enable the CAA to accept the number of persons and their qualifications, an organisation should make an analysis of the tasks to be performed, the way in which it intends to divide and/or combine these tasks, indicate how it intends to assign responsibilities and establish the number of man/hours and the qualifications needed to perform the tasks. With significant changes in the aspects relevant to the number and qualifications of persons needed, this analysis should be updated.
4. Nominated person or group of persons should have:
 - 4.1 practical experience and expertise in the application of aviation safety standards and safe operating practices;
 - 4.2 a comprehensive knowledge of:
 - (a) relevant parts of operational requirements and procedures;
 - (b) the AOC holder's Operations Specifications when applicable;
 - (c) the need for, and content of, the relevant parts of the AOC holder's Operations Manual when applicable;
 - 4.3 knowledge of quality systems;
 - 4.4 five years relevant work experience of which at least two years should be from the aeronautical industry in an appropriate position;
 - 4.5 a relevant engineering degree or an aircraft maintenance technician qualification with additional education acceptable to the CAA. 'relevant engineering degree' means an engineering degree from aeronautical, mechanical, electrical, electronic, avionic or other studies relevant to the maintenance and continuing airworthiness of aircraft/ aircraft components;

The above recommendation may be replaced by 5 years of experience additional to those already recommended by paragraph 4.4 above. These 5 years should cover an appropriate combination of experience in tasks related to aircraft maintenance and/or continuing airworthiness management and/or surveillance of such tasks
 - 4.6 thorough knowledge with the organisation's continuing airworthiness management exposition;
 - 4.7 knowledge of a relevant sample of the type(s) of aircraft gained through a formalised training course. These courses should be at least at a level equivalent to MCAR-66 Appendix III Level 1 General Familiarisation and could be imparted by a MCAR-147 organisation, by the manufacturer, or by any other organisation accepted by the CAA.

“Relevant sample” means that these courses should cover typical systems embodied in those aircraft being within the scope of approval.

For all balloons and any other aircraft of 2730 Kg MTOM and below the formalised training courses may be replaced by demonstration of knowledge. This knowledge may be demonstrated by documented evidence or by an assessment performed by the CAA. This assessment should be recorded.

4.8 knowledge of maintenance methods.

4.9 knowledge of applicable regulations

AMC M.A.706(a) Personnel requirements

Accountable manager is normally intended to mean the chief executive officer of the CAMO, who by virtue of position has overall (including in particular financial) responsibility for running the organisation. The accountable manager may be the accountable manager for more than one organisation and is not required to be knowledgeable on technical matters. When the accountable manager is not the chief executive officer, the CAA will need to be assured that such an accountable manager has direct access to the chief executive officer and has a sufficiency of continuing airworthiness funding allocation.

AMC M.A.706(e) Personnel requirements

1. The CAA should only accept that the nominated post holder be employed by the organisation approved under MCAR-145 when it is manifest that he/she is the only available competent person in a position to exercise this function, within a practical working distance from the operator's offices.
2. This paragraph only applies to contracted maintenance and therefore does not affect situations where the organisation approved under MCAR-145 and the operator are the same organisation.

AMC M.A.706(f) Personnel requirements

Additional training in fuel tank safety as well as associated inspection standards and maintenance procedures should be required of CAMO technical personnel, especially the staff involved with the management of CDCCL, Service Bulletin assessment, work planning and maintenance programme management. CAA guidance is provided for training to CAMO personnel in Appendix XII to AMC to M.A.706(f).

AMC M.A.706(i) Personnel requirements

The approval by the CAA of the exposition, containing in M.A.704(a)3 the list of M.A.706(i) personnel, constitutes their formal acceptance by the CAA and also their formal authorisation by the organisation.

Airworthiness review staff are automatically recognised as persons with authority to extend an airworthiness review certificate in accordance with M.A.711(a)4 and M.A.901(f) or M.L.A.901(c) as applicable.

AMC M.A.706(k) Personnel requirements

Adequate initial and recurrent training should be provided and recorded to ensure continued competence.

MCAR-M.A.707 Airworthiness review staff

- (a) To be approved to carry out airworthiness reviews and, if applicable, to issue permits to fly, an approved continuing airworthiness management organisation shall have appropriate airworthiness review staff to issue airworthiness review certificates or recommendations referred to in Section A, Subpart I of this Regulation or in Section A, Subpart I of MCAR-ML and, if applicable, to issue a permit to fly in accordance with point M.A.711(c):
1. For aircraft used by licenced air carriers, and aircraft above 2730 kg MTOM, except balloons, these staff shall have acquired:
 - (a) at least 5 years' experience in continuing airworthiness, and
 - (b) an appropriate license in compliance with MCAR-66 or an aeronautical degree; and
 - (c) formal aeronautical maintenance training; and
 - (d) a position within the approved organisation with appropriate responsibilities.
 - (e) Notwithstanding points (a) to (d), the requirement laid down in point M.A.707(a)1(b) may be replaced by five years of experience in continuing airworthiness additional to those already required by point M.A.707(a)1(a).
 2. For aircraft not used by licenced air carriers of 2730 kg MTOM and below, and balloons, these staff shall have acquired:
 - (a) at least 3 years' experience in continuing airworthiness; and
 - (b) an appropriate license in compliance with MCAR-66 or an aeronautical degree; and
 - (c) appropriate aeronautical maintenance training; and
 - (d) a position within the approved organisation with appropriate responsibilities;
 - (e) Notwithstanding points (a) to (d), the requirement laid down in point M.A.707(a)2(b) may be replaced by four years of experience in continuing airworthiness additional to those already required by point M.A.707(a)2(a).
- (b) Airworthiness review staff nominated by the approved continuing airworthiness organisation can only be issued an authorisation by the approved continuing airworthiness organisation when formally accepted by the CAA after satisfactory completion of an airworthiness review under supervision of the CAA or under the supervision of the organisation's airworthiness review staff in accordance with a procedure approved by the CAA.
- (c) The organisation shall ensure that aircraft airworthiness review staff can demonstrate appropriate recent continuing airworthiness management experience.
- (d) Airworthiness review staff shall be identified by listing each person in the continuing airworthiness management exposition together with their airworthiness review authorisation reference.
- (e) The organisation shall maintain a record of all airworthiness review staff, which shall include details of any appropriate qualification held together with a summary of relevant continuing airworthiness

management experience and training and a copy of the authorisation. This record shall be retained until two years after the airworthiness review staff have left the organisation.

AMC M.A.707(a) Airworthiness review staff

1. Airworthiness review staff are only required if the CAMO wants to be granted M.A.711(b) airworthiness review and, if applicable, M.A.711(c) permit to fly privileges.
2. “experience in continuing airworthiness” means any appropriate combination of experience in tasks related to aircraft maintenance and/or continuing airworthiness management and/or surveillance of such tasks.
3. A person qualified to the AMC M.A.706 subparagraph 4.5 should be considered as holding the equivalent to an aeronautical degree.
4. An appropriate licence in compliance with MCAR-66 is any one of the following:
 - a category B1 licence in the subcategory of the aircraft reviewed, or
 - a category B2 or C licence, or
 - in the case of piston-engine non-pressurised aeroplanes of 2 000 kg MTOM and below, a category B3 licence.
 - in the case of sailplanes, powered sailplanes, ELA1 aeroplanes, balloons and airships, a category L licence in the appropriate subcategory.

It is not necessary to satisfy the experience requirements of MCAR-66 at the time of the review.

5. To hold a position with appropriate responsibilities means the airworthiness review staff should have a position in the organisation independent from the airworthiness management process or with overall authority on the airworthiness management process of complete aircraft.

Independence from the airworthiness management process may be achieved, among other ways, by:

- Being authorised to perform airworthiness reviews only on aircraft for which the person has not participated in their management. For example, performing airworthiness reviews on a specific model line, while being involved in the airworthiness management of a different model line.
- M.A. Subpart G organisations with MCAR-145/M.A.Subpart F/ MCAR-CAO approval, may nominate maintenance personnel from their MCAR-145/M.A.Subpart F/ MCAR-CAO organisation as airworthiness review staff, as long as they are not involved in the airworthiness management of the aircraft. These personnel should not have been involved in the release to service of that particular aircraft (other than maintenance tasks performed during the physical survey of the aircraft or performed as a result of findings discovered during such physical survey) to avoid possible conflict of interests.

- Nominating as airworthiness review staff personnel from the Quality Department of the CAMO.

Overall authority on the airworthiness management process of complete aircraft may be achieved, among other ways, by:

- Nominating as airworthiness review staff the Accountable Manager or the nominated Postholder.
- Being authorised to perform airworthiness reviews only on those particular aircraft for which the person is responsible for the complete continuing airworthiness management process.
- In the case of one-man organisations, this person has always overall authority. This means that this person can be nominated as airworthiness review staff.

AMC M.A.707(a)(1) Airworthiness review staff

For all aircraft used in by licenced air carriers and for any other aircraft, other than balloons, above 2730 kg MTOM, formal aeronautical maintenance training means training (internal or external) supported by evidence on the following subjects:

- Relevant parts of initial and continuing airworthiness regulations.
- Relevant parts of operational requirements and procedures, if applicable.
- The organisation’s continuing airworthiness management exposition.
- Knowledge of a relevant sample of the type(s) of aircraft gained through a formalised training course. These courses should be at least at a level equivalent to MCAR-66 Appendix III Level 1 General Familiarisation and could be imparted by a MCAR-147 organisation, by the manufacturer, or by any other organisation accepted by the CAA.
- “Relevant sample” means that these courses should cover typical systems embodied in those aircraft being within the scope of approval
- Maintenance methods.

AMC M.A.707(a)(2) Airworthiness review staff

For all balloons and any other aircraft of 2730 Kg MTOM and below, not used by licenced air carriers:

1. “experience in continuing airworthiness” can be full-time or part-time, either as professional or on a voluntary basis.
2. Appropriate aeronautical maintenance training means demonstrated knowledge of the following subjects:
 - Relevant parts of initial and continuing airworthiness regulations.
 - Relevant parts of operational requirements and procedures, if applicable.
 - The organisation’s continuing airworthiness management exposition.

- Knowledge of a relevant sample of the type(s) of aircraft gained through training and/ or work experience. Such knowledge should be at least at a level equivalent to MCAR-66 Appendix III Level 1 General Familiarisation and could be imparted by a MCAR-147 organisation, by the manufacturer, or by any other organisation accepted by the CAA.

“Relevant sample” means that these courses should cover typical systems embodied in those aircraft being within the scope of approval.

- Maintenance methods.

This knowledge may be demonstrated by documented evidence or by an assessment performed by the CAA or by other airworthiness review staff already authorised within the organisation in accordance with approved procedures. This assessment should be recorded.

AMC M.A.707(b) Airworthiness review staff

The formal acceptance by the CAA of the airworthiness review staff is granted through the corresponding CAA Form 4.

If the airworthiness review is performed under the supervision of existing airworthiness review staff, evidence should be provided to the CAA together with the CAA Form 4. If satisfied, the CAA will issue the formal acceptance through the CAA Form 4.

Once the airworthiness review staff has been accepted by the CAA, the inclusion of their name in the exposition (refer to M.A.704(a)5) constitutes the formal authorisation by the organisation.

AMC M.A.707(c) Airworthiness review staff

In order to keep the validity of the airworthiness review staff authorisation, the airworthiness review staff should have either:

- been involved in continuing airworthiness management activities for at least six months in every two year period, or
- conducted at least one airworthiness review in the last twelve month period.

In order to restore the validity of the authorisation, the airworthiness review staff should conduct at a satisfactory level an airworthiness review under the supervision of the CAA or, if accepted by the CAA, under the supervision of another currently valid authorised airworthiness review staff of the concerned continuing airworthiness management organisation in accordance with an approved procedure.

AMC M.A.707(e) Airworthiness review staff

The minimum content of the airworthiness review staff record should be:

- Name,
- Date of Birth,
- Basic Education,

- Experience,
- Aeronautical Degree and/or MCAR-66 qualification,
- Initial Training received,
- Type of Training received,
- Continuation Training received,
- Experience in continuing airworthiness and within the organisation,
- Responsibilities of current role in the organisation,
- Copy of the authorisation.

MCAR-M.A.708 Continuing Airworthiness Management

- (a) The organisation shall ensure that all continuing airworthiness management is carried out in accordance with Section A, Subpart C of this Regulation, and Section A, Subpart C of MCAR-ML, as applicable.
- (b) For every aircraft managed, the approved continuing airworthiness management organisation shall:
 - 1. shall ensure that an aircraft maintenance programme including any applicable reliability programme, as required by point M.A.302 of this Regulation or MCAR-ML.A.302, as applicable, is developed and controlled,
 - 2. for aircraft not used by licenced air carriers provide a copy of the aircraft maintenance programme to the owner or operator responsible in accordance with M.A.201 of this Regulation or MCAR-ML.A.201, as applicable,
 - 3. manage the approval of modification and repairs,
 - 4. ensure that all maintenance is carried out in accordance with the approved maintenance programme and released in accordance with Section A, Subpart H of this Regulation or Section A, Subpart H of MCAR-ML, as applicable,
 - 5. ensure that all applicable airworthiness directives and operational directives with a continuing airworthiness impact, are applied,
 - 6. ensure that all defects discovered during scheduled maintenance or reported are corrected by an appropriately approved maintenance organisation,
 - 7. ensure that the aircraft is taken to an appropriately approved maintenance organisation whenever necessary,
 - 8. coordinate scheduled maintenance, the application of airworthiness directives, the replacement of service life limited parts, and component inspection to ensure the work is carried out properly,

9. manage and archive all continuing airworthiness records and/or operator's technical log.
 10. ensure that the mass and balance statement reflects the current status of the aircraft.
- (c) In the case of complex motor-powered aircraft or aircraft used for CAT or aircraft used for commercial specialised operations or commercial ATO operations or commercial DTO operations, when the CAMO is not appropriately approved in accordance with MCAR-145 or Subpart F of this Regulation or MCAR-CAO, the organisation shall in consultation with the operator, establish a written maintenance contract with an organisation approved in accordance with MCAR-145 or Subpart F of this Regulation or MCAR-CAO or with another operator, detailing the functions specified under points M.A.301(b), M.A.301(c), M.A.301(f) and M.A.301(g) of this Regulation, or points ML.A.301(b) to (e) of MCAR-ML, ensuring that all maintenance is ultimately carried out by a maintenance organisation approved in accordance with MCAR-145 or Subpart F of this Regulation or MCAR-CAO and defining the support of the quality functions referred to in point M.A.712(b) of this Regulation.
- (d) Notwithstanding point (c), the contract may be in the form of individual work orders addressed to the maintenance organisation approved in accordance with MCAR-145 or Subpart F of this Regulation or MCAR-CAO in the case of:
1. An aircraft requiring unscheduled line maintenance
 2. Component maintenance, including engine maintenance

GM M.A.708 Continuing airworthiness management

The CAMO should have adequate knowledge of the design status (type specification, customer options, airworthiness directive (ADs), airworthiness limitations contained in the aircraft instructions for continuing airworthiness, modifications, major repairs, operational equipment) and of the required and performed maintenance. The status of aircraft design and maintenance should be adequately documented to support the performance of the quality system.

For CS-25 aeroplanes, adequate knowledge of the airworthiness limitations should cover those contained in EASA CS-25 Book 1, Appendix H, paragraph H25.4 and fuel tank system airworthiness limitations including critical design configuration control limitations (CDCCL).

AMC M.A.708(b)(3) Continuing Airworthiness Management

When managing the approval of modifications or repairs the organisation should ensure that Critical Design Configuration Control Limitations are taken into account.

GM M.A.708(b)(4) Continuing airworthiness management

This requirement means that the CAMO is responsible for determining what maintenance is required, when it has to be performed, by whom and to what standard in order to ensure the continued airworthiness of the aircraft.

AMC1 M.A.708(c) Continuing airworthiness management

1. In case of complex motor-powered aircraft, aircraft used for CAT operations, aircraft used for commercial specialised operations and aircraft used by commercial ATO, the provisions of M.A.201

establish that a CAMO is required. This CAMO is in charge of the continuing airworthiness management and this includes the tasks specified in M.A.301 paragraphs (b), (c), (e) and (g). If the CAMO does not hold the appropriate maintenance organisation approval, then the CAMO should conclude a contract with the appropriate organisation(s).

2. The CAMO bears the responsibility for the airworthy condition of the aircraft for which it performs the continuing airworthiness management. Thus, it should be satisfied before the intended flight that all required maintenance has been properly carried out.
3. The CAMO should agree with the operator on the process to select a maintenance organisation before concluding any contract with a maintenance organisation.
4. The fact that the CAMO has contracted a maintenance organisation approved under Subpart F or MCAR-145 should not prevent it from checking at the maintenance facilities on any aspect of the contracted work to fulfil its responsibility for the airworthiness of the aircraft.
5. The contract between the CAMO and the maintenance organisation(s) should specify in detail the responsibilities and the work to be performed by each party.
6. Both the specification of work and the assignment of responsibilities should be clear, unambiguous and sufficiently detailed to ensure that no misunderstanding arises between the parties concerned that could result in a situation where work that has an effect on the airworthiness or serviceability of aircraft is not or will not be properly performed.
7. Special attention should be paid to procedures and responsibilities to ensure that all maintenance work is performed, service bulletins are analysed and decisions are taken on their accomplishment, airworthiness directives accomplished on time and that all work, including non-mandatory modifications, is carried out to approved data and to the latest standards.
8. Appendix XI to this AMC gives further details on the subject.

AMC2 M.A.708(c) Continuing airworthiness management
MAINTENANCE CONTRACT WITH ANOTHER CAMO/OPERATOR

1. The purpose of M.A.708(c) is to ensure that all maintenance is carried out by an appropriately approved maintenance organisation. It is possible to contract another operator/CAMO (secondary operator/CAMO) that does not hold a maintenance organisation approval when it proves that such a contract is in the interest of the CAMO by simplifying the management of its maintenance, and the CAMO keeps an appropriate control of it. In this case the continuing airworthiness management exposition should include appropriate procedures to ensure that all maintenance is ultimately carried out on time by approved maintenance organisations in accordance with the CAMO's data. In particular, the quality system procedures should place great emphasis on monitoring compliance with the above. The list of approved maintenance organisations, or a reference to this list, should be included in the CAMO's continuing airworthiness management exposition.
2. This contract should not preclude the CAMO from ensuring that all maintenance is performed by appropriately approved organisations which comply with the M.A.201 continuing airworthiness responsibility requirements. Typical examples of such arrangements are the following:

– Component maintenance:

The CAMO may find it more appropriate to have a primary contractor (the secondary operator/CAMO) dispatching the components to appropriately approved organisations rather than sending themselves different types of components to various maintenance organisations approved under MCAR-145. The benefit for the CAMO is that the management of maintenance is simplified by having a single point of contact for component maintenance. The CAMO remains responsible for ensuring that all maintenance is performed by maintenance organisations approved under MCAR-145 and in accordance with the approved standard.

– Aircraft, engine and component maintenance:

The CAMO may wish to have a maintenance contract with a secondary operator/CAMO not approved under MCAR-145 for the same type of aircraft. A typical case is that of a dry-leased aeroplane between operators where the parties, for consistency or continuity reasons (especially for short-term lease agreements), find it appropriate to keep the aeroplane under the current maintenance arrangement. Where this arrangement involves various MCAR-145 approved contractors, it might be more manageable for the lessee CAMO to have a single maintenance contract with the lessor operator/CAMO. Whatever type of acceptable maintenance contract is concluded, the CAMO is required to exercise the same level of control on contracted maintenance, particularly through the M.A.706(c) continuing airworthiness management group of persons and quality system as referred to in M.A.712.

GM M.A.708(c) Continuing airworthiness management

For line maintenance, the actual layout of the IATA Standard Ground Handling Agreement may be used as a basis, but this does not preclude the CAMO from ensuring that the content of the contract is acceptable and especially that the contract allows the CAMO to properly exercise its maintenance responsibility. Those parts of the contract that have no effect on the technical or operational aspects of airworthiness are outside the scope of this paragraph.

AMC M.A.708(d) Continuing airworthiness management

The intent of this paragraph is that maintenance contracts are not necessary when the continuing airworthiness management exposition specifies that the relevant maintenance activity may be ordered through one-time work orders. This includes unscheduled line maintenance and may also include component maintenance up to engines, as long as the maintenance is manageable through work orders, both in terms of volume and complexity. It should be noted that this paragraph implies that even where base maintenance is ordered on a case-by-case basis, there should be a written maintenance contract.

MCAR-M.A.709 Documentation

- (a) The approved continuing airworthiness management organisation shall hold and use applicable current maintenance data in accordance with point M.A.401 of this Regulation or MCAR-ML.A.401, as applicable, for the performance of continuing airworthiness tasks referred to in point M.A.708. That data may be provided by the owner or the operator, subject to an appropriate contract being established with such an owner or operator. In such case, the continuing airworthiness management organisation only needs to keep such data for the duration of the contract, except when required by point M.A.714.

- (b) For aircraft not used by licenced air carriers, the approved continuing airworthiness management organisation may develop “baseline” or “generic” maintenance programmes, or both in order to allow for the initial approval or the extension of the scope of an approval without having the contracts referred to in Appendix I to this Regulation or Appendix I to Annex MCAR-ML, as applicable. Those “baseline” and “generic” maintenance programmes however do not preclude the need to establish an adequate Aircraft Maintenance Programme in compliance with point M.A.302 or MCAR-ML.A.302, as applicable, in due time before exercising the privileges referred to in point M.A.711.

AMC M.A.709 Documentation

When using maintenance data provided by the customer, the CAMO is responsible for ensuring that this data is current. As a consequence, it should establish appropriate procedures or provisions in the contract with the customer.

The sentence “..., except when required by point M.A.714”, means, in particular, the need to keep a copy of the customer data which was used to perform continuing airworthiness activities during the contract period.

“Baseline” maintenance programme: it is a maintenance programme developed for a particular aircraft type following, where applicable, the maintenance review board (MRB) report, the type certificate holder’s maintenance planning document (MPD), the relevant chapters of the maintenance manual or any other maintenance data containing information on scheduling.

“Generic” maintenance programme: it is a maintenance programme developed to cover a group of similar types of aircraft. These programmes should be based on the same type of instructions as the baseline maintenance programme. Examples of “generic” maintenance programmes could be Cessna 100 Series (covering Cessna 150, 172, 177, etc.).

“Baseline” and “generic” maintenance programmes are not applicable to a particular aircraft registration mark, but to an aircraft type or group of types, and should be available to the CAA prior to the initial approval and prior to the extension of the scope of an existing organisation approval. The intent is that the CAA is aware of the scope and complexity of tasks that will be managed before granting an organisation approval or change of approval.

After this initial approval, when an owner/operator is contracted, the baseline or generic maintenance programme, as applicable, may be used to establish the M.A.302 aircraft maintenance programme, incorporating the additional maintenance tasks and indicating those which are not applicable to a particular aircraft registration mark. This may be achieved by adding an Annex to the baseline/generic maintenance programme for each aircraft registration, specifying which tasks are added and which are not applicable. This will result in an aircraft maintenance programme specific for each customer.

However, this does not mean that this adaptation must be performed for each contracted aircraft registration. The reason is that the customer may already have an approved aircraft maintenance programme, which in that case should be used by the continuing airworthiness management organisation to manage the continuing airworthiness of such aircraft.

Continuing airworthiness management organisations may seek authorisation for indirect approval in order to amend the aircraft maintenance programme mentioned above in accordance with M.A.302(c). The indirect approval procedure should include provisions to notify to the CAA that an aircraft maintenance programme specific for a customer has been created. The reason is that, according to M.A.704(a)9, for aircraft not used by licenced air carriers, the Continuing Airworthiness Management Exposition (CAME) only needs to include the reference to the baseline/generic maintenance programme.

GM M.A.709 Documentation

Paragraph M.A.709(a) refers to continuing airworthiness tasks referred to in M.A.708. As a consequence, this covers continuing airworthiness management tasks but not airworthiness reviews.

Airworthiness review requirements are established in M.A.710 and the requirements for the corresponding records retention are contained in M.A.714.

MCAR-M.A.710 Airworthiness review

When the organisation approved in accordance with point M.A.711(b) of this Regulation performs airworthiness reviews, they shall be performed in accordance with point M.A.901 of this Regulation or point ML.A.903 of MCAR-ML, as applicable.

GM M.A.710 Airworthiness review

RESPONSIBILITIES OF AIRWORTHINESS REVIEW STAFF:

The following is a summary of the requirements contained in M.A.710 as well as the associated AMCs and Appendices, in relation to the responsibilities of the airworthiness review staff:

- Airworthiness review staff are responsible for performing both the documental and the physical survey.
- Procedures must be established by the CAMO in order to perform the airworthiness review, including depth of samplings (refer to Appendix V to AMC1 M.A.704, paragraphs 4.2 and 4.3).
- Procedures must make very clear that the final word about the depth of the inspections (both documental and physical) belongs to the airworthiness review staff, who can go beyond the depth contained in the CAME if they find it necessary. At the end, it is the responsibility of the airworthiness review staff to be satisfied that the aircraft complies with MCAR-M, as applicable, and is airworthy, and the organisation must ensure that no pressure or restrictions are imposed on the airworthiness review staff when performing their duty.
- A compliance report must be produced by the airworthiness review staff, detailing all items checked and the outcome of the review.
- Airworthiness review staff are responsible for the items checked during the airworthiness review. However, they do not take over the responsibilities of the CAMO, MCAR-145, DOA, POA or any other organisations, not being responsible for problems not detected during the airworthiness review or for the possibility that the approved or declared maintenance programme may not include certain recommendations from the Design Approval Holder. Obviously, if the airworthiness review staff are not independent of the airworthiness management process and were nominated on the basis of the option of having overall authority on such a process, they will be responsible for the full continuing airworthiness of such aircraft. Nevertheless, this responsibility will be a consequence of their position related to M.A.706 and not of their position as airworthiness review staff (M.A.707).
- The issuance of the airworthiness review certificate (ARC) by the airworthiness review staff only certifies that the aircraft is considered airworthy in relation to the scope of the airworthiness review performed and the fact that the airworthiness review staff are not aware of instances of non-compliance which endanger flight safety. Furthermore, it only certifies that the aircraft is considered airworthy at the time of the review.

It is the responsibility of the owner or contracted CAMO to ensure that the aircraft is fully airworthy at any time.

MCAR-M.A.711 Privileges of the organisation

- (a) A continuing airworthiness management organisation approved in accordance with Section A, Subpart G of this Regulation may:
1. manage the continuing airworthiness of aircraft, except those used by licenced air carriers, as listed on the approval certificate.
 2. manage the continuing airworthiness of aircraft used by licenced air carriers, when listed both on its approval certificate and on its Air Operator Certificate (AOC);
 3. arrange to carry out limited continuing airworthiness tasks with any contracted organisation, working under its quality system, as listed on the approval certificate;
 4. extend, under the conditions of point M.A.901(f) of this Regulation or MCAR-ML.A.901(c), as applicable, an airworthiness review certificate that has been issued by the CAA or by another organisation or person, as applicable ;
 5. Approve the AMP, in accordance with point (b)(2) of point MCAR-ML.A.302, for aircraft managed in accordance with MCAR-ML.
- (b) An approved continuing airworthiness management organisation registered in the Maldives may, additionally, be approved to carry out airworthiness reviews referred to in point M.A.710 and:
1. issue the related airworthiness review certificate and extend it in due time under the conditions of points M.A.901(c)(2) or M.A.901(e)(2) or point MCAR-ML.A.901(c), as applicable; and,
 2. issue a recommendation for the airworthiness review to the CAA.
- (c) A continuing airworthiness management organisation whose approval includes the privileges referred to in point M.A.711(b) may additionally be approved to issue a permit to fly in accordance with MCAR-21.A.711(d) for the particular aircraft for which the organisation is approved to issue the airworthiness review certificate, when the continuing airworthiness management organisation is attesting conformity with approved flight conditions, subject to an adequate approved procedure in the exposition referred to in point M.A.704.

AMC M.A.711(a)(3) Privileges of the organisation

SUBCONTRACTING OF CONTINUING AIRWORTHINESS TASKS

1. The CAMO may subcontract certain continuing airworthiness management tasks to qualified persons or organisations. The subcontracted person or organisation performs the continuing airworthiness management tasks as an integral part of the CAMO's continuing airworthiness management system, irrespective of any other approval held by the subcontracted person or organisation (including CAMO or MCAR-145 approval).
2. The CAMO remains accountable for the satisfactory completion of the continuing airworthiness management tasks irrespective of any contract that may be established.

3. In order to fulfil this responsibility, the CAMO should be satisfied that the actions taken by the subcontracted person or organisation meet the standards required by Subpart G. Therefore, the CAMO management of such activities should be accomplished:
 - (a) By active control through direct involvement, and/or
 - (b) By endorsing the recommendations made by the subcontracted person or organisation.
4. In order to retain ultimate responsibility, the CAMO should limit subcontracted tasks to the activities specified below:
 - (a) Airworthiness directive analysis and planning;
 - (b) Service bulletin analysis;
 - (c) Planning of maintenance;
 - (d) Reliability monitoring, engine health monitoring;
 - (e) Maintenance programme development and amendments;
 - (f) Any other activities, which do not limit the CAMO responsibilities, as agreed by the CAA.
5. The CAMO's control associated with subcontracted continuing airworthiness management tasks should be reflected in the associated contract and be in accordance with the CAMO policy and procedures defined in the continuing airworthiness management exposition. When such tasks are subcontracted, the continuing airworthiness management system is considered to be extended to the subcontracted person or organisations.
6. With the exceptions of engines and auxiliary power units, contracts would normally be limited to one organisation per aircraft type for any combination of the activities described in Appendix II. Where contracts are made with more than one organisation, the CAMO should demonstrate that adequate coordination controls are in place and that the individuals' responsibilities are clearly defined in the related contracts.
7. Contracts should not authorise the subcontracted organisation to subcontract to other organisations elements of the continuing airworthiness management tasks.
8. The CAA should exercise oversight of the subcontracted activities through the CAMO approval. The contracts should be acceptable to the CAA. The CAMO should only subcontract to organisations which are specified by the CAA on CAA Form 14.
9. The subcontracted organisation should agree to notify the CAMO of any changes affecting the contract as soon as practical. The CAMO should then inform the CAA. Failure to do so may invalidate the CAA's acceptance of the contract.
10. Appendix II to AMC M.A.711(a)(3) provides information on the subcontracting of continuing airworthiness management tasks.

AMC M.A.711(b) Privileges of the organisation

An organisation may be approved for the privileges of M.A.711(a) only, without the privilege to carry out airworthiness reviews. This can be contracted to another appropriately approved organisation. In such a case, it is not mandatory that the contracted organisation is linked to an AOC holder, being possible to contract an appropriately approved independent continuing airworthiness management organisation which is approved for the same aircraft type.

In order to be approved for the privileges of M.A.711(b) for a particular aircraft type, it is necessary to be approved for the privileges of M.A.711(a) for that aircraft type. As a consequence, the normal situation in this case is that the organisation will be performing continuing airworthiness management tasks and performing airworthiness reviews on every aircraft type contained in the approval certificate.

Nevertheless, this does not necessarily mean that the organisation needs to be currently managing an aircraft type in order to be able to perform airworthiness reviews on that aircraft type. The organisation may be performing only airworthiness reviews on an aircraft type without having any customer under contract for that type.

Furthermore, this situation should not necessarily lead to the removal of the aircraft type from the organisation approval. As a matter of fact, since in most cases the airworthiness review staff are not involved in continuing airworthiness management activities, it cannot be argued that these airworthiness review staff are going to lose their skills just because the organisation is not managing a particular aircraft type. The important issue in relation to maintaining a particular aircraft type in the organisation approval is whether the organisation continuously fulfils all the Subpart G requirements (facilities, documentation, qualified personnel, quality system, etc.) required for initial approval.

AMC M.A.711(c) Privileges of the organisation

The sentence 'for the particular aircraft for which the organisation is approved to issue the airworthiness review certificate' contained in M.A.711(c) means that:

- For aircraft used in licenced air carriers, and for aircraft above 2730 kg MTOM, , the permit to fly can only be issued for aircraft which are in a controlled environment and are managed by that CAMO.
- The permit to fly can be issued for any other aircraft for which the organisation can exercise the privilege in M.A.711(b).

MCAR-M.A.712 Quality system

- (a) To ensure that the approved continuing airworthiness management organisation continues to meet the requirements of this Subpart, it shall establish a quality system and designate a quality manager to monitor compliance with, and the adequacy of, procedures required to ensure airworthy aircraft. Compliance monitoring shall include a feedback system to the accountable manager to ensure corrective action as necessary.
- (b) The quality system shall monitor activities carried out under Section A, Subpart G of this Regulation. It shall at least include the following functions:
 - 1. monitoring that all activities carried out under Section A, Subpart G of this Regulation are being performed in accordance with the approved procedures, and;
 - 2. monitoring that all contracted maintenance is carried out in accordance with the contract, and;
 - 3. monitoring the continued compliance with the requirements of this Regulation.
- (c) The records of these activities shall be stored for at least two years.
- (d) Where the approved continuing airworthiness management organisation is approved in accordance with another MCAR, the quality system may be combined with that required by the other regulation.
- (e) For licenced air carriers the M.A. Subpart G quality system shall be an integrated part of the operator's quality system.
- (f) In the case of a small organisation not managing the continuing airworthiness of aircraft used by licenced air carriers, the quality system may be replaced by regular organisational reviews subject to the approval of the CAA, except when the organisation issues airworthiness review certificates for aircraft above 2730 kg MTOM other than balloons. In the case where there is no quality system, the organisation shall not contract continuing airworthiness management tasks to other parties.

AMC M.A.712(a) Quality system

- 1. Procedures should be held current such that they reflect best practice within the organisation. It is the responsibility of all employees to report any difficulties with the procedures via their organisation's internal occurrence reporting mechanisms.
- 2. All procedures, and changes to the procedures, should be verified and validated before use where practicable.
- 3. The feedback part of the system should address who is required to rectify any non-compliance in each particular case and the procedure to be followed if rectification is not completed within appropriate timescales. The procedure should lead to the accountable manager specified in M.A.706.
- 4. The independent quality audit reports referenced in AMC M.A.712 (b) should be sent to the relevant department for rectification action giving target rectification dates. Rectification dates should be discussed with such department before the quality department or nominated quality auditor confirms such dates in the report. The relevant department is required to rectify findings and inform the quality manager or the quality auditor of such rectification.

5. The accountable manager should hold regular meetings with staff to check progress on rectification except that in the large organisations such meetings may be delegated on a day to day basis to the quality manager subject to the accountable manager meeting at least twice per year with the senior staff involved to review the overall performance and receiving at least a half yearly summary report on findings of non-compliance.

AMC M.A.712(b) Quality system

1. The primary objectives of the quality system are to enable the CAMO to ensure airworthy aircraft and to remain in compliance with the MCAR-M and, as applicable, MCAR-ML requirements.
2. An essential element of the quality system is the independent audit.
3. The independent audit is an objective process of routine sample checks of all aspects of the CAMO ability to carry out continuing airworthiness management to the required standards. It includes some product sampling as this is the end result of the process.
4. The independent audit represents an objective overview of the complete continuing airworthiness management related activities. It is intended to complement the M.A.902 or MCAR-ML.A.902 requirement for an airworthiness review to be satisfied that all aircraft managed by the organisation remain airworthy.
5. The independent audit should ensure that all aspects of M.A. Subpart G compliance are checked annually, including all the sub-contracted activities, and may be carried out as a complete single exercise or subdivided over the annual period in accordance with a scheduled plan. The independent audit does not require each procedure to be checked against each product line when it can be shown that the particular procedure is common to more than one product line and the procedure has been checked every year without resultant findings. Where findings have been identified, the particular procedure should be rechecked against other product lines until the findings have been rectified after which the independent audit procedure may revert back to the annual interval for the particular procedure. Provided that there are no safety related findings, the audit time periods specified in this AMC may be increased by up to 100% subject to agreement by the CAA.
6. Where the organisation has more than one location approved the quality system should describe how these are integrated into the system and include a plan to audit each location every year.
7. A report should be raised each time an audit is carried out describing what was checked and the resulting findings against applicable requirements, procedures and products.
8. The independence of the audit should be established by always ensuring that audits are carried out by personnel not responsible for the function, procedure or products being checked.
9. An organisation should establish a quality plan acceptable to the CAA to show when and how often the activities as required by M.A. Subpart G will be audited.

AMC M.A.712(f) Quality system

A small organisation is considered to be an organisation with up to 5 full-time staff (including all M.A.706 personnel) or equivalent proportional number when using part-time staff. The complexity of the organisation, combination of aircraft and aircraft types, the utilisation of the aircraft and the number of

approved locations of the organisations should also be considered before replacing the quality system by an organisational review.

Appendix XIII to this AMC should be used to manage the organisational reviews.

The following activities should not be considered as subcontracting and, as a consequence, they may be performed without a quality system, although they need to be described in the continuing airworthiness management exposition and be approved by the CAA:

- Subscription to a technical publisher that provides maintenance data (Aircraft Maintenance Manuals, Illustrated Parts Catalogues, Service Bulletins, etc.), which may be applicable to a wide range of aircraft. These data may include maintenance schedules recommended by different manufacturers that can be afterwards used by the continuing airworthiness management organisation in order to produce customised maintenance programmes.
- Contracting the use of a software tool for the management of continuing airworthiness data and records, under the following conditions (in addition to M.A.714(d) and (e)):
 - If the tool is used by several organisations, each organisation should have access to its own data only.
 - Introduction of data can only be performed by personnel of the continuing airworthiness management organisation.
 - The data can be retrieved at any time.

MCAR-M.A.713 Changes to the approved continuing airworthiness organisation

In order to enable the CAA to determine continued compliance with this Regulation, the approved continuing airworthiness management organisation shall notify it of any proposal to carry out any of the following changes, before such changes take place:

1. the name of the organisation.
2. the location of the organisation.
3. additional locations of the organisation.
4. the accountable manager.
5. any of the persons specified in M.A.706(c).
6. the facilities, procedures, work scope and staff that could affect the approval.

In the case of proposed changes in personnel not known to the management beforehand, these changes shall be notified at the earliest opportunity.

AMC M.A.713 Changes to the approved continuing airworthiness organisation

This paragraph covers scheduled changes to the CAMO approval. The primary purpose of this paragraph is to enable the CAMO to remain approved if agreed by the CAA during negotiations about any of the specified changes. Without this paragraph the approval would automatically be suspended in all cases.

MCAR-M.A.714 Record-keeping

- (a) The continuing airworthiness management organisation shall record all details of work carried out. The records required by M.A.305 or MCAR-ML.A.305, as applicable, and if applicable M.A.306 shall be retained.
- (b) If the continuing airworthiness management organisation has the privilege referred to in point M.A.711(b), it shall retain a copy of each airworthiness review certificate and recommendation issued or, as applicable, extended, together with all supporting documents. In addition, the organisation shall retain a copy of any airworthiness review certificate that it has extended under the privilege referred to in point M.A.711(a)4.
- (c) If the continuing airworthiness management organisation has the privilege referred to in point M.A.711(c), it shall retain a copy of each permit to fly issued in accordance with the provisions of MCAR-21.A.729.
- (d) The continuing airworthiness management organisation shall retain a copy of all records referred to in points (b) and (c) until two years after the aircraft has been permanently withdrawn from service.
- (e) The records shall be stored in a manner that ensures protection from damage, alteration and theft.
- (f) All computer hardware used to ensure backup shall be stored in a different location from that containing the working data in an environment that ensures they remain in good condition.
- (g) Where continuing airworthiness management of an aircraft is transferred to another organisation or person, all retained records shall be transferred to the said organisation or person. The time periods prescribed for the retention of records shall continue to apply to the said organisation or person.
- (h) Where a continuing airworthiness management organisation terminates its operation, all retained records shall be transferred to the owner of the aircraft.

AMC M.A.714 Record-keeping

1. The CAMO should ensure that it always receives a complete CRS from the approved maintenance organisation, M.A.801(b)(1) certifying staff and/or from the Pilot-owner such that the required records can be retained. The system to keep the continuing airworthiness records should be described in the organisation continuing airworthiness management exposition.
2. When an organisation arranges for the relevant maintenance organisation to retain copies of the continuing airworthiness records on its behalf, it will nevertheless continue to be responsible for the records under M.A.714 relating to the preservation of records. If it ceases to be the organisation of the aircraft, it also remains responsible for transferring the records to any other person or organisation managing continuing airworthiness of the aircraft.

3. Keeping continuing airworthiness records in a form acceptable to the CAA means in paper form or on a computer database or a combination of both methods. Records stored in microfilm or optical disc form are also acceptable. The record should remain legible throughout the required retention period.
4. Paper systems should use robust material which can withstand normal handling and filing.
5. Computer systems should have at least one backup system which should be updated within 24 hours of any new entry. Each terminal is required to contain programme safeguards against the ability of unauthorised personnel to alter the database.

Microfilming or optical storage of continuing airworthiness records may be carried out at any time. The records should be as legible as the original record and remain so for the required retention period.

MCAR-M.A.715 Continued validity of approval

- (a) An approval shall remain valid until 01 May 2023, subject to:
 1. the organisation remaining in compliance with this Regulation, in accordance with the provisions related to the handling of findings as specified under point M.B.705 and;
 2. the CAA being granted access to the organisation to determine continued compliance with this Regulation, and;
 3. the approval not being surrendered or revoked.
- (b) Upon surrender or revocation, the approval certificate shall be returned to the CAA.

MCAR-M.A.716 Findings

- (a) A level 1 finding is any significant non-compliance with the requirements of MCAR-M or MCAR-ML, as applicable, which lowers the safety standard and hazards seriously the flight safety;
- (b) A level 2 finding is any non-compliance with the requirements of MCAR-M or MCAR-ML, as applicable, which could lower the safety standard and possibly hazard the flight safety.
- (c) After receipt of notification of findings according to point M.B.705, the holder of the continuing airworthiness management organisation approval shall define a corrective action plan and demonstrate corrective action to the satisfaction of the CAA within a period agreed with the authority.

Subpart H — CERTIFICATE OF RELEASE TO SERVICE – CRS

MCAR-M.A.801 Aircraft certificate of release to service

- (a) Except for aircraft released to service by a maintenance organisation approved in accordance with MCAR-145, the CRS shall be issued in accordance with this Subpart;
- (b) No aircraft can be released to service unless a CRS is issued when all maintenance tasks ordered have been properly carried out. The CRS shall be issued by an authorised certifying staff of the maintenance organisation approved in accordance with Subpart F of this Regulation or with MCAR-CAO, except for maintenance tasks other than complex maintenance tasks listed in Appendix VII to this Annex where the CRS is issued, alternatively by:
 - 1. independent certifying staff acting in accordance with the requirements of MCAR-66;
 - 2. by the Pilot-owner in compliance with point M.A.803.
- (c) By derogation from point (b), in the case of unforeseen situations, when an aircraft is grounded at a location where no maintenance organisation approved in accordance with this Regulation, MCAR-145 or MCAR-CAO and no independent certifying staff are available, the owner may authorise any person, with not less than 3 years of appropriate maintenance experience and holding either a valid ICAO Annex 1 compliant maintenance license for the aircraft type requiring certification or a certifying staff authorisation valid for the work requiring certification issued by an ICAO Annex 6 approved maintenance organisation to maintain the aircraft in accordance with the standards set out in Subpart D of this Regulation and release it to service. In that case, the owner shall:
 - 1. obtain and keep in the aircraft records specifying details of the maintenance carried out and of the qualifications of the person issuing the CRS;
 - 2. ensure that any such maintenance is later on verified and a new CRS is issued by an appropriately authorised person referred to in point (b) or an organisation approved in accordance with Subpart F of this Regulation, MCAR-145 or MCAR-CAO, at the earliest opportunity and in any case within 7 calendar days from the issuance of a CRS by the person authorised by the owner;
 - 3. notify the organisation responsible for the continuing airworthiness management of the aircraft, when contracted, or the CAA in the absence of such a contract, within seven days of the issuance of such certification authorisation.
- (d) In case of a release to service in accordance with point (b)(1), the certifying staff may be assisted in performing the maintenance tasks by one or more persons subject to his or her direct and continuous control;
- (e) A CRS shall contain at least:
 - 1. basic details of the maintenance carried out; and
 - 2. the date on which the maintenance was completed;
 - 3. the identity of the organisation or person issuing the CRS, including, alternatively:

- (i) the approval reference of the maintenance organisation and the certifying staff issuing the CRS;
 - (ii) in the case referred to in point (b)2 the identity and, where applicable, the licence number of the certifying staff issuing the CRS;
4. the limitations to airworthiness or operations, if any.
- (f) By derogation from point (b) and notwithstanding point (g) when the required maintenance cannot be completed, a CRS may be issued with the approved aircraft limitations. In that case, the certificate shall indicate that the maintenance could not be completed, as well as indicate any applicable airworthiness or operations limitations, as part of the information required by point (e)(4).
- (g) A CRS shall not be issued in the case of any known non-compliance which endangers flight safety.

AMC M.A.801 Aircraft certificate of release to service after embodiment of a Standard Change or a Standard Repair (SC/SR)

1. Release to service and eligible persons

Only natural or legal persons entitled to release to service an aircraft after maintenance in accordance with MCAR-M, MCAR-145 or MCAR-CAO are considered as an eligible installer responsible for the embodiment of a SC/SR when in compliance with applicable requirements.

- For aircraft where there is no MCAR-66 license applicable, the release to service of an aircraft after embodiment of a SC/SR is only possible by holders of an appropriate certifying staff qualification validated or accepted by the CAA.

Depending on its nature, for certain SCs/SRs, the EASA CS-STAN might restrict the eligibility for the issuance of the release to service to certain persons.

Since the design of the SC/SR does not require specific approval, the natural or legal person releasing the aircraft to service after the embodiment of the change or repair takes the responsibility that the applicable Certification Specifications within CS-STAN are fulfilled while being in compliance with MCAR-M, MCAR-145 or MCAR-CAO and not in conflict with TC holders' data. This includes responsibility in respect of an adequate design, the selection/manufacturing of suitable parts and their identification, documenting the change or repair, generation or amendment of aircraft manuals and instructions as needed, embodiment of the change/repair, releasing the aircraft to service and record-keeping.

2. Parts and appliances to be installed as part of a SC/SR

The design of the parts and appliances to be used in a SC/SR is considered a part of the change/repair, and, therefore, there is no need of a specific design approval. However, it is possible that for a particular SC, these Certification Specifications specifically require the use of parts and appliances that meet a technical standard. In this case, when the parts and appliances require to be authorised as an ETSO article, other articles recognised as equivalent by means of an international safety agreement or grandfathered in accordance with MCAR-21 are equally acceptable.

Normally, a SC/SR shall not contain specifically designed parts that should be produced by a production organisation. However, in the case that the change or repair would contain such a part, it should be produced by an acceptable Production Organization (POA), and delivered with a CAA Form 1 or equivalent.

Eligibility for installation of parts and appliances belonging to a SC/SR is subject to compliance with the MCAR-21 and MCAR-M, MCAR-145 and MCAR-CAO related provisions, and the situation varies depending on the aircraft in/on which the SC/SR is to be embodied, and who the installer is. The need for a CAA Form 1 is addressed in MCAR-21 and MCAR-M.. Furthermore, MCAR-M Subpart F, MCAR-145 and MCAR-CAO contain provisions (i.e. M.A.603(c) and MCAR-145.A.42(c) and MCAR-CAO.A.020(c)) allowing maintenance organisations to fabricate certain parts to be installed in/on the aircraft as part of their maintenance activities.

3. Parts and appliances identification

The parts modified or installed during the embodiment of the SC/SR need to be permanently marked in accordance with MCAR-21 Subpart Q.

4. Documenting the SC/SR and declaring compliance with the Certification Specifications

In accordance with MCAR-M, MCAR-CAO or MCAR-145 (e.g. AMC M.A.801(e) and MCAR-145.A.50(b)), the legal or natural person responsible for the embodiment of a change or a repair should compile details of the work accomplished. In the case of SCs/SRs, this includes, as necessary, based on its complexity, an engineering file containing drawings, a list of parts and appliances used for the change or repair, supporting analysis and the results of tests performed or any other evidence suitable to show that the design fulfils the applicable Certification Specifications within EASA CS-STAN together with a statement of compliance and amendments to aircraft manuals, to instructions for continuing airworthiness and to other documents such as aircraft parts list, wiring diagrams, etc., as deemed necessary. The CAA Form 123 is prepared for the purpose of documenting the preparation and embodiment of the SC/SR. The aircraft logbook should contain an entry referring to CAA Form 123; both CAA Form 123 and the release to service required after the embodiment of the SC/SR should be signed by the same person.

CAA Form 123 and all the records on it should follow elementary principles of controlled documentation, e.g. contain reference number of documents, issue dates, revision numbers, name of persons preparing/releasing the document, etc.

5. Record-keeping

The legal or natural person responsible (see paragraph 1. above) for the embodiment of the change/repair should keep the records generated with the SC/SR as required by MCAR-M or MCAR-145 and EASA CS-STAN.

In addition, M.A.305 requires that the aircraft owner (or CAMO, if a contract i.a.w. M.A.201 exists) keeps the status of the changes/repairs embodied in/on the aircraft in order to control the aircraft configuration and manage its continuing airworthiness.

With regard to SCs/SRs, the information provided to the owner or CAMO may be listed in CAA Form 123 and should include, as required, a copy of any modified aircraft manual and/or instructions for continuing airworthiness. All this information should normally be consulted when the aircraft undergoes an airworthiness review, and, therefore, a clear system to record the embodiment of SCs/SRs, which is also easily traceable, would be of help during subsequent aircraft inspections.

6. Instructions for continuing airworthiness

As stipulated in M.A.302, the aircraft owner or CAMO needs to assess if the changes in the instructions for continuing airworthiness of the aircraft require to amend the aircraft maintenance programme and to obtain its approval.

7. Embodiment of more than one SC

The embodiment of two or more related SCs described in Subpart B of CS-STAN is permitted as a single change (the use of one CAA Form 123 only) as long as adequate references to and records of all SCs embodied are captured. Restrictions and limitations of the two (or more) SCs would apply. It is permitted to issue a single release to service containing adequate traceability of all the SCs embodied.

8. Acceptable form to be used to record the embodiment of SCs/SRs

CAA FORM 123 – Standard Change/Standard Repair (SC/SR) embodiment record

CAA FORM 123 – Standard Change/Standard Repair (SC/SR) embodiment record		^{1.} SC/SR number(s):
^{2.} SC/SR title & description:		
^{3.} Applicability:		
^{4.} List of parts (description/Part-No/Qty):		
^{5.} Operational limitations/affected aircraft manuals. Copies of these manuals are provided to the aircraft owner:		
^{6.} Documents used for the development and embodiment of this SC/SR:		
* Copies of the documents marked with an asterisk are handed over to the aircraft owner.		
^{7.} Instructions for continuing airworthiness. Copies of these manuals are provided to the aircraft owner:		
^{8.} Other information:		
^{9a.} <input type="checkbox"/> This SC complies with the criteria established in 21.A.90B(a) and with the relevant paragraphs of CS-STAN.		
^{9b.} <input type="checkbox"/> This SR complies with the criteria established in 21.A.431B(a) and with the relevant paragraphs of CS-STAN.		
^{10.} Date of SC/SR embodiment:	^{11.} Identification data and signature of the person responsible for the embodiment of the SC/SR:	
^{12.} Signature of the aircraft owner. This signature attests that all relevant documentation is handed over from the issuer of this form to the aircraft owner, and, therefore, the latter becomes aware of any impact or limitations on operations or additional continuing airworthiness requirements which may apply to the aircraft due to the embodiment of the change/repair.		

CAA Form 123, Issue 1.00, 01 June 2019

Notes:

Original remains with the legal or natural person responsible for the embodiment of the SC/SR.

The aircraft owner should retain a copy of this form.

The aircraft owner should be provided with copies of the documents referenced in boxes 5 and 7 and those in box 6 marked with an asterisk '*'.

The 'relevant paragraphs' in boxes 9a and 9b refer to the applicable paragraphs of 'Subject A – General' of CS-STAN and those of the SC/SR quoted in box 2.

For box 12, when the aircraft owner has signed a contract i.a.w. MCAR-ML.A.201 or M.A.201 as applicable, it is possible that the Continuing Airworthiness Management Organisation (CAMO) representative signs box 12 and provides all relevant information to the owner before next flight.

Completion Instructions:

Use English to fill in the form.

1. Identify the SC/SR with a unique number and reference this number in the aircraft logbook.
2. Specify the applicable EASA CS-STAN chapter including revision (e.g. CS-SCxxx or CS-SRxxx) & title. Provide also a short description.
3. Identify the aircraft (a/c) registration, serial number and type.
4. List the parts' numbers and description for the parts installed. Refer to an auxiliary document if necessary.
5. Identify affected aircraft manuals.
6. Refer to the documentation developed to support the SC/SR and its embodiment, including design data required by the CS-STAN: design definition, documents recording the showing of compliance with the Certification Specifications or any tests result, etc. The documents' references should quote their revision/issue.
7. Identify instructions for continuing airworthiness that need to be considered for the aircraft maintenance programme review.
8. To be used as deemed necessary by the installer.

9a., 9b., 10. And 12. Self-explanatory.

Give the full name details and certificate reference (of the natural or legal person) used for issuing the aircraft release to service.

CAA Form 123, Issue 1.02, 15 November 2021

AMC M.A.801(b) Aircraft certificate of release to service

A certificate of release to service is necessary before flight, at the completion of any defect rectification, whilst the aircraft operates a flight between scheduled maintenance checks.

AMC M.A.801(c) Aircraft certificate of release to service

AIRCRAFT GROUNDED AT OTHER LOCATIONS

1. "3 years of appropriate maintenance experience" means 3 years working in an aircraft maintenance environment on at least some of the aircraft type systems corresponding to the aircraft endorsed on the aircraft maintenance license or on the certifying staff authorisation that the person holds.
2. "Holding the proper qualifications" means holding either:
 - (a) a valid ICAO Annex 1 compliant maintenance license for the aircraft type requiring certification, or;
 - (b) a certifying staff authorisation valid for the work requiring certification, issued by an ICAO Annex 6 approved maintenance organisation.
3. A release in accordance with this paragraph does not affect the controlled environment, in accordance with point (b) of M.A.901, of the aircraft as long as the M.A.801(c)2 recheck and release has been carried out by an approved maintenance organisation.

AMC M.A.801(e) Aircraft certificate of release to service

1. The aircraft certificate of release to service should contain the following statement:
 - (a) 'Certifies that the work specified except as otherwise specified was carried out in accordance with MCAR-M and in respect to that work the aircraft is considered ready for release to service'.
 - (b) For a Pilot-owner a certificate of release to service should contain the following statement:

'Certifies that the limited pilot-owner maintenance specified except as otherwise specified was carried out in accordance with MCAR-M and in respect to that work the aircraft is considered ready for release to service'.
2. The certificate of release to service should relate to the task specified in the manufacturer's or operator's instruction or the aircraft maintenance programme which itself may cross-refer to a manufacturer's/operator's instruction in a maintenance manual, service bulletin etc.
3. The date such maintenance was carried out should include when the maintenance took place relative to any life or overhaul limitation in terms of date/flying hours/cycles/landings etc., as appropriate.
4. When extensive maintenance has been carried out, it is acceptable for the certificate of release to service to summarise the maintenance so long as there is a unique cross-reference to the work-pack containing full details of maintenance carried out. Dimensional information should be retained in the work-pack record.
5. The person issuing the certificate of release to service should use his normal signature except in the case where a computer release to service system is used. In this latter case the CAA will need to be

satisfied that only the particular person can electronically issue the release to service. One such method of compliance is the use of a magnetic or optical personal card in conjunction with a personal identity number (PIN) known only to the individual, which is keyed into the computer. A certification stamp is optional.

6. At the completion of all maintenance, owners, certifying staff, operators and maintenance organisations should ensure they have a clear, concise, legible record of the work performed.
7. In the case of an M.A.801 (b) 1 release to service, certifying staff should retain all records necessary to prove that all requirements have been met for the issuance of a certificate of release to service.

AMC M.A.801(f) Aircraft certificate of release to service
INCOMPLETE MAINTENANCE

1. Being unable to establish full compliance with sub-paragraph M.A.801 (b) means that the maintenance required by the aircraft owner, CAO or CAMO could not be completed due either to running out of available aircraft maintenance downtime or because the maintenance data requires a flight to be performed as part of the maintenance, as described in paragraph 4.
2. The aircraft owner, CAO or CAMO is responsible for ensuring that all required maintenance has been carried out before flight. Therefore an aircraft owner, CAO or CAMO should be informed and agree to the deferment of full compliance with M.A.801(b). The certificate of release to service may then be issued subject to details of the deferment, including the aircraft owner, CAO or CAMO authorisation, being endorsed on the certificate.
3. If a CRS is issued with incomplete maintenance a record should be kept stating what action the mechanic, supervisor and certifying staff should take to bring the matter to the attention of the relevant aircraft owner, CAO or CAMO so that the issue may be discussed and resolved with the aircraft owner, CAO or CAMO.
4. Certain maintenance data issued by the design approval holder (e.g. aircraft maintenance manual (AMM)) require that a maintenance task be performed in flight as a necessary condition to complete the maintenance ordered. Within the aircraft limitations, the person authorised to certify the maintenance per M.A.801 should release the incomplete maintenance before this flight. GM M.A.301(i) describes the relations with the aircraft operator, which retains the responsibility for the MCF. After performing the flight and any additional maintenance necessary to complete the maintenance ordered, a certificate of release to service should be issued in accordance with M.A.801.

AMC M.A.801(g) Aircraft certificate of release to service

'Endangers flight safety' means any instance where safe operation could not be assured or which could lead to an unsafe condition. It typically includes, but is not limited to, significant cracking, deformation, corrosion or failure of primary structure, any evidence of burning, electrical arcing, significant hydraulic fluid or fuel leakage and any emergency system or total system failure. An AD overdue for compliance is also considered a hazard to flight safety.

MCAR-M.A.802 Component certificate of release to service

- (a) Except for components released to service by a maintenance organisation that is approved in accordance with MCAR-145 and for the cases covered by point (e) of point M.A.502, a CRS shall be issued at the completion of any maintenance carried out on an aircraft component in accordance with point M.A.502.
- (b) The authorised release certificate identified as CAA Form 1 constitutes the component CRS, except when such maintenance on aircraft components has been performed in accordance with point (b) or (d) of point M.A.502 in which case the maintenance is subject to aircraft release procedures in accordance with point M.A.801.

AMC M.A.802 Component certificate of release to service

The purpose of the CAA Form 1 (see also Appendix II to MCAR-M) is to release components after manufacture and to release maintenance work carried out on such components under the approval of the CAA, and to allow components that are removed from one aircraft/component to be fitted to another aircraft/component.

When an approved organisation maintains an aircraft component for use by the organisation a CAA Form 1 may not be necessary depending upon the organisation's internal release procedures; however all the information normally required for the CAA Form 1 should be adequately detailed in the certificate of release to service.

MCAR-M.A.803 Pilot-owner authorisation

- (a) To qualify as a Pilot-owner, the person must:
 - 1. hold a valid pilot licence (or equivalent) issued or validated by the CAA for the aircraft type or class rating; and
 - 2. own the aircraft, either as sole or joint owner; that owner must be:
 - (i) one of the natural persons on the registration form; or
 - (ii) a member of a non-profit recreational legal entity, where the legal entity is specified on the registration document as owner or operator, and that member is directly involved in the decision making process of the legal entity and designated by that legal entity to carry out Pilot-owner maintenance.
- (b) For any other than complex motor-powered aircraft of 2730 kg MTOM and below, which are not used in CAT operations, in commercial specialised operations or in commercial operations by ATOs or DTOs, the Pilot-owner may issue a CRS after having carried out limited Pilot-owner maintenance as specified in Appendix VIII.
- (c) The scope of the limited Pilot-owner maintenance shall be specified in the aircraft maintenance programme referred to in point M.A.302.
- (d) The CRS shall be entered in the aircraft continuing airworthiness record system and contain basic details of the maintenance carried out, the maintenance data used, the date on which that maintenance was completed, as well as the identity, the signature and pilot licence number of the Pilot-owner issuing such a certificate.

AMC M.A.803 Pilot-owner authorisation

1. Privately operated means the aircraft is operated pursuant to M.A.201(i).
2. A Pilot-owner may only issue a CRS for maintenance he/ she has performed.
3. In the case of a jointly-owned aircraft, the maintenance programme should list:
 - The names of all Pilot-owners competent and designated to perform Pilot-owner maintenance in accordance with the basic principles described in Appendix VIII of MCAR-M. An alternative would be the maintenance programme to contain a procedure to ensure how such a list of competent Pilot-owners should be managed separately and kept current.
 - The limited maintenance tasks they may perform.
4. An equivalent valid pilot license may be any document attesting a pilot qualification issued by another state and recognised by the CAA. It does not have to be necessarily issued by the CAA, but it should in any case be issued in accordance with the other State's system. In such a case, the equivalent certificate or qualification number should be used instead of the pilot's licence number for the purpose of the M.A.801(b)(2) (certificate of release to service).
5. Not holding a valid medical examination does not invalidate the pilot license (or equivalent) required under M.A.803(a)1 for the purpose of the Pilot-owner authorisation.

Subpart I — AIRWORTHINESS REVIEW CERTIFICATE

MCAR-M.A.901 Aircraft airworthiness review

To ensure the validity of the aircraft airworthiness certificate, an airworthiness review of the aircraft and its continuing airworthiness records shall be carried out periodically.

- (a) An airworthiness review certificate is issued in accordance with Appendix III (CAA Form 15a or 15b) upon completion of a satisfactory airworthiness review. The airworthiness review certificate shall be valid for 1 year;
- (b) An aircraft in a controlled environment is an aircraft which, during the preceding 12 months:
 - 1. has had its airworthiness continuously managed by a unique CAMO or CAO;
 - 2. has been maintained by a maintenance organisations approved in accordance with Section A, Subpart F of this Regulation, MCAR-145 or MCAR-CAO, including the cases when maintenance tasks referred to in point (b) of point M.A.803 are carried out and released to service in accordance with point (b)(1) or (b)(2) of point M.A.801.
- (c) For all aircraft used by licenced air carriers, and for aircraft above 2730 kg MTOM, that are in a controlled environment, the organisation referred to in (b)(1) managing the continuing airworthiness of the aircraft may in accordance with MCAR-CAMO.A.125(e) or point M.A.711(b) or point MCAR-CAO.A.095(c)(1), as applicable, and subject to compliance with point (j):
 - 1. issue an airworthiness review certificate in accordance with point M.A.901,;
 - 2. extend at most twice the validity of the airworthiness review certificate it has issued, for a period of 1 year each time, where the aircraft concerned has remained within a controlled environment.
- (d) The airworthiness review certificate shall be issued by the CAA upon a satisfactory assessment based on a recommendation made by a CAMO or CAO, sent together with the application from the owner or operator for all aircraft used by licensed air carriers, and for aircraft above 2730 kg MTOM that complies with the following alternative conditions:
 - 1. they are not in a controlled environment;
 - 2. their continuing airworthiness is managed by an organisation that does not hold the privilege to carry out airworthiness reviews.

The recommendation referred to in the first subparagraph shall be based on an airworthiness review carried out in accordance with point M.A.901.

- (e) For aircraft of 2730 kg MTOM and below not used by licenced air carriers, any CAMO or CAO chosen by the owner or operator may in accordance with MCAR-CAMO.A.125(e) or point M.A.711(b) or MCAR-CAO.A.095(c), as applicable, and subject to compliance with point (j):
 - 1. issue the airworthiness review certificate in accordance with point M.A.901;
 - 2. extend at most twice the validity of the airworthiness review certificate it has issued, for a period of 1 year each time, where the aircraft has remained within a controlled environment under its management.

- (f) By derogation from points (c)2 and (e)2 of point M.A.901, for aircraft that are in a controlled environment, the organisation referred to in (b)(1) managing the continuing airworthiness of the aircraft, may, subject to compliance with paragraph (j), extend at most twice the validity of an airworthiness review certificate that the CAA or another CAMO or CAO has issued, for a period of 1 year each time.
- (g) Whenever circumstances reveal the existence of a potential risk to aviation safety, the CAA shall carry out the airworthiness review and issue the airworthiness review certificate itself.
- (h) Without prejudice to point (g), the CAA may also carry out the airworthiness review and issue the airworthiness review certificate itself in the following cases:
1. when the continuing airworthiness of the aircraft is managed by a CAMO or CAO which has its principal place of business located outside Maldives;
 2. for any other aircraft of 2730 kg MTOM and below, if the owner so requests.
- (i) Where the CAA issues the airworthiness review certificate itself in accordance with points (g) or (h) or after assessing the recommendation in accordance with point M.B.901, the owner or operator of the aircraft shall, where necessary for those purposes, provide the CAA with:
1. any documentation required by the CAA;
 2. suitable accommodation at the appropriate location for its personnel;
 3. the support of the certifying staff
- (j) An airworthiness review certificate shall not be issued, nor extended if there is evidence or indications that the aircraft is not airworthy.
- (k) The airworthiness review of the aircraft shall include a full documented review of the aircraft records establishing that the following requirements have been met:
1. airframe, engine and propeller flying hours and associated flight cycles have been properly recorded;
 2. the flight manual is applicable to the aircraft configuration and reflects the latest revision status;
 3. all the maintenance due on the aircraft pursuant to the approved AMP has been carried out;
 4. all known defects have been corrected or, when applicable, carried forward in a controlled manner in accordance with M.A.403;
 5. all applicable ADs have been applied and properly registered;
 6. all modifications and repairs applied to the aircraft have been registered and are in compliance with point M.A.304;
 7. all life-limited parts and time-controlled components installed on the aircraft are properly identified, registered and have not exceeded their limitation;

8. all maintenance has been carried out in accordance with this Regulation;
 9. the current mass and balance statement reflects the current configuration of the aircraft and is valid;
 10. the aircraft complies with the latest revision of its type design (accepted by the CAA);
 11. if required, the aircraft holds a noise certificate corresponding to the current configuration of the aircraft in compliance with MCAR-21.
- (l) The airworthiness review of the aircraft shall include a physical survey of the aircraft. For that survey, airworthiness review staff not appropriately qualified in accordance with MCAR-66 shall be assisted by such qualified staff.
- (m) Through the physical survey of the aircraft, the airworthiness review staff shall ensure that:
1. all required markings and placards are properly installed;
 2. the aircraft complies with its approved flight manual;
 3. the aircraft configuration complies with the approved documentation;
 4. no evident defect can be found that has not been addressed in accordance with point M.A.403;
 5. no inconsistencies can be found between the aircraft and the documented review of records referred to in point (k).
- (n) By derogation from point (a), the airworthiness review may be anticipated by a maximum period of 90 days without loss of continuity of the airworthiness review pattern, so as to allow for the physical review to take place during a maintenance check.
- (o) The airworthiness review certificate (CAA Form 15b) or the recommendation for the issue of the airworthiness review certificate (CAA Form 15a) referred to in Appendix III to this Regulation can only be issued:
1. by authorised airworthiness review staff on behalf of the approved organisation;
 2. if the airworthiness review has been completely carried out.
- (p) A copy of any airworthiness review certificate issued or extended for an aircraft shall be sent to the CAA within 10 days.
- (q) Airworthiness review tasks shall not be subcontracted.
- (r) Should the outcome of the airworthiness review be inconclusive, the organisation having carried out the review shall inform the CAA as soon as possible and in any case within 72 hours from the moment the organisation identifies the reason for which the airworthiness review is inconclusive.
- (s) The airworthiness review certificate shall not be issued until all findings have been closed.

AMC M.A.901 Aircraft airworthiness review

In order to ensure the validity of the aircraft airworthiness certificate, M.A.901 requires performing periodically an airworthiness review of the aircraft and its continuing airworthiness records, which results in the issuance of an airworthiness review certificate valid for one year.

GM M.A.901 Airworthiness review

Responsibilities of airworthiness review staff:

The following is a summary of the requirements contained in M.A.901 as well as the associated AMC and Appendices, in relation to the responsibilities of the airworthiness review staff:

- Airworthiness review staff are responsible for performing both the documental and the physical survey.
- Procedures must be established by the CAMO or CAO in order to perform the airworthiness review, including the depth of samplings.
- Procedures must make very clear that the final word about the depth of the inspections (both documental and physical) belongs to the airworthiness review staff, who can go beyond the depth established in the CAME or CAE if they find it necessary. At the end, it is the responsibility of the airworthiness review staff to be satisfied that the aircraft complies with MCAR-M and is airworthy, and the organisation must ensure that no pressure or restrictions are imposed on the airworthiness review staff when performing their duty.
- A compliance report must be produced by the airworthiness review staff, detailing all items checked and the outcome of the review.
- Airworthiness review staff are responsible for the items checked during the airworthiness review. However, they do not take over the responsibilities of the CAMO, maintenance organisation, DOA, POA or any other organisations, not being responsible for problems not detected during the airworthiness review or for the possibility that the approved or declared maintenance programme may not include certain recommendations from the design approval holder. Obviously, if the airworthiness review staff are not independent of the airworthiness management process and were nominated on the basis of the option of having overall authority on such a process, they will be responsible for the full continuing airworthiness of such aircraft. Nevertheless, this responsibility will be a consequence of their position in the organisation and not of their function as airworthiness review staff.
- The issuance of the airworthiness review certificate (ARC) by the airworthiness review staff only certifies that the aircraft is considered airworthy in relation to the scope of the airworthiness review performed and the fact that the airworthiness review staff are not aware of instances of non-compliance which endanger flight safety. Furthermore, it only certifies that the aircraft is considered airworthy at the time of the review.

It is the responsibility of the owner or contracted CAMO or CAO to ensure that the aircraft is fully airworthy at any time.

GM M.A.901(a) Aircraft airworthiness review

CAA Form 15a is issued by the CAA while CAA Form 15b is issued by a CAMO or CAO organisation.

AMC M.A.901(b) Aircraft airworthiness review

1. If the continuing airworthiness of the aircraft is not managed according to an Appendix I Continuing airworthiness contract, the aircraft should be considered to be outside a controlled environment. Nevertheless, such contract is not necessary when the operator and the CAMO are the same organisation.
2. The fact that limited pilot-owner maintenance as defined in M.A.803 (b) is not carried out and released by an approved maintenance organisation does not change the status of an aircraft in a controlled environment providing the CAMO under contract has been informed of any such maintenance carried out.

AMC M.A.901(c)(2), (e)(2) and (f) Aircraft airworthiness review

When the aircraft has remained within a controlled environment, the extension of the validity of the airworthiness review certificate does not require an airworthiness review but only a verification of the continuous compliance with M.A.901 (b).

It is acceptable to anticipate the extension of the airworthiness review certificate by a maximum of 30 days without a loss of continuity of the airworthiness review pattern, which means that the new expiration date is set up one year after the previous expiration date. This anticipation of up to 30 days also applies to the 12 month requirements shown in M.A.901(b), meaning that the aircraft is still considered as being in a controlled environment if it has been continuously managed by a single organisation and maintained by appropriately approved organisations, as stated in M.A.901(b), from the date when the last airworthiness review certificate was issued until the date when the extension is performed (this can be up to 30 days less than 12 months).

It is also acceptable to perform the extension of an airworthiness review certificate after its expiration date, as long as all the conditions for the extension are met. However, this means the following:

- The aircraft could not fly since the airworthiness review certificate expired until it is extended, and
- The new expiration date (after extension) is set one year after the previous expiration date (not one year after the extension is performed).

AMC M.A.901(d) Aircraft airworthiness review

The recommendation sent by a CAMO or CAO to the CAA should contain at least the items described below.

- (a) General information
 - CAMO information
 - owner/lessee information
 - date and place where the document review and the aircraft survey were carried out
 - period and place the aircraft can be seen if required by the CAA

(b) Aircraft information

- Registration
- Type
- Manufacturer
- serial number
- flight manual reference
- weight and centre of gravity data
- maintenance programme reference

(c) Documents accompanying the recommendation

- copy of registration papers
- copy of the owners request for a new airworthiness review certificate

(d) Aircraft status

- aircraft total time and cycles
- list of persons or organisations having carried out continuing airworthiness activities including maintenance tasks on the aircraft and its components since the last airworthiness review certificate

(e) Aircraft survey

- a precise list of the areas of the aircraft that were surveyed and their status

(f) Findings

- a list of all the findings made during the airworthiness review with the corrective action carried out

(g) Statement

A statement signed by the airworthiness review staff recommending the issue of an airworthiness review certificate.

The statement should confirm that the aircraft in its current configuration complies with the following:

- airworthiness directives up to the latest published issue, and;
- type certificate datasheet;
- maintenance programme;

- limitation for life-limited parts and time-controlled components;
- the valid weight and centre of gravity schedule reflecting the current configuration of the aircraft;
- MCAR-21 for all modifications and repairs;
- the current flight manual including supplements, and;
- operational requirements.

The above items should clearly state the exact reference of the data used in establishing compliance; for instance the number and issue of the type certificate data sheet used should be stated.

The statement should also confirm that all of the above is properly entered and certified in the aircraft continuing airworthiness record system and/or in the operator's technical log.

AMC M.A.901(i) Aircraft airworthiness review

Suitable accommodation should include:

- (a) an office with normal office equipment such as desks, telephones, photocopying machines etc. whereby the continuing airworthiness records can be reviewed.
- (b) a hangar when needed for the physical survey.

The support of personnel appropriately qualified in accordance with MCAR-66 is necessary when the CAA's airworthiness review staff is not appropriately qualified.

AMC M.A.901(k) Aircraft airworthiness review

FULL DOCUMENTED REVIEW

1. A full documented review is a check of at least the following categories of documents:
 - registration papers;
 - M.A.305 aircraft continuing airworthiness record system;
 - M.A.306 aircraft technical log system;
 - list of deferred defects, minimum equipment list and configuration deviation, list if applicable;
 - aircraft flight manual including aircraft configuration;
 - aircraft maintenance programme;
 - maintenance data;
 - relevant work packages;
 - AD status;

- modification and SB status;
- modification and repair approval sheets;
- status of life-limited parts and time-controlled components;
- relevant EASA Form 1 or equivalent;
- mass and balance report and equipment list;
- aircraft, engine and propeller TC data sheets.

As a minimum, sample checks within each document category should be carried out.

2. The CAMO or CAO should develop procedures for the airworthiness review staff to produce a compliance report that confirms the above have been reviewed and found in compliance with MCAR-M.

AMC M.A.901(l) and (m) Aircraft airworthiness review
PHYSICAL SURVEY

1. The physical survey could require actions categorised as maintenance (e.g. operational tests, tests of emergency equipment, visual inspections requiring panel opening, etc.). In this case, after the airworthiness review, a release to service should be issued.
2. When the airworthiness review staff are not appropriately qualified as per MCAR-66 in order to release such maintenance, M.A.901(l) requires them to be assisted by such qualified personnel. However, the function of such MCAR-66 personnel is limited to performing and releasing the maintenance actions requested by the airworthiness review staff, it not being their function to perform the physical survey of the aircraft.
3. This means that the airworthiness review staff who is going to sign the airworthiness review certificate or the recommendation should be the one performing both the documented review and the physical survey of the aircraft. It is not the intent of the rule to delegate the survey to MCAR-66 personnel who are not airworthiness review staff. Furthermore, the provision of M.A.901(n) that allows a 90-day anticipation for the physical survey provides enough flexibility to ensure that the airworthiness review staff (ARS) are present.
4. The physical survey may include verifications to be carried out during flight.
5. The CAMO or CAO should develop procedures for the ARS to produce a compliance report that confirms that the physical survey has been carried out and found satisfactory.
6. To ensure compliance, the physical survey may include relevant sample checks of items.

AMC M.A.901(n) Aircraft airworthiness review

'Without loss of continuity of the airworthiness review pattern' means that the new expiration date is set up 1 year after the previous expiration date. As a consequence, when the airworthiness review is anticipated, the validity of the airworthiness review certificate is longer than 1 year (up to 90 days longer).

This anticipation of up to 90 days also applies to the 12-month requirements shown in M.A.901(b), which means that the aircraft is still considered as being in a controlled environment if it has been continuously managed by a single organisation and maintained by appropriately approved organisations, as stated in M.A.901(b), from the date when the last airworthiness review certificate was issued until the date when the new airworthiness review is performed (this can be up to 90 days less than 12 months).

AMC M.A.901(o) Airworthiness review

A copy of both the physical survey and document review compliance reports stated above should be sent to the CAA together with any recommendation issued.

MCAR-M.A.902 Validity of the airworthiness review certificate

- (a) An airworthiness review certificate becomes invalid if:
1. suspended or revoked; or
 2. the airworthiness certificate is suspended or revoked; or
 3. the aircraft is not on the aircraft register of the Maldives; or
 4. the type certificate under which the airworthiness certificate was issued is suspended or revoked.
- (b) An aircraft must not fly if the airworthiness certificate is invalid or if:
1. the continuing airworthiness of the aircraft or any component fitted to the aircraft does not meet the requirements of this Regulation; or;
 2. the aircraft does not remain in conformity with the type design approved by the State of Design; or
 3. the aircraft has been operated beyond the limitations of the approved flight manual or the airworthiness certificate, without appropriate action being taken; or
 4. the aircraft has been involved in an accident or incident that affects the airworthiness of the aircraft, without subsequent appropriate action to restore airworthiness; or
 5. a modification or repair is not in compliance with the MCAR-21.
- (c) Upon surrender or revocation, the airworthiness review certificate shall be returned to the CAA.

MCAR-M.A.903 Transfer of registration within Maldives

- (a) When transferring an aircraft registration within the Maldives, the applicant shall:
1. (reserved)
 2. apply to the CAA for the issuance of a new airworthiness certificate in accordance with MCAR-21.

- (b) Notwithstanding point M.A.902(a)(3), the former airworthiness review certificate shall remain valid until its expiry date.

AMC M.A.903(b) Transfer of aircraft registration within Maldives

In case of transfer of aircraft registration within Maldives, the aircraft owner/operator should verify that the CAA has entered the new aircraft registration on the existing airworthiness review certificate and validated the change.

MCAR-M.A.904 Airworthiness review of aircraft imported into the Maldives

- (a) When importing an aircraft, the applicant shall:
1. apply to the CAA for the issuance of a new airworthiness certificate in accordance with MCAR-21;
 2. for aircraft other than new, have an airworthiness review carried out satisfactorily in accordance with point M.A.901; and
 3. have all maintenance carried out to comply with the AMP in accordance with point M.A.302.
- (b) When satisfied that the aircraft is in compliance with the relevant requirements, the organisation performing the airworthiness review, shall send a documented recommendation for the issuance of an airworthiness review certificate to the CAA.
- (c) The owner of the aircraft shall allow access to the aircraft for inspection by the CAA.
- (d) The CAA shall issue an airworthiness certificate when it is satisfied the aircraft complies with the requirements of MCAR-21.
- (e) The CAA shall also issue the airworthiness review certificate. The certificate shall be valid for 1 year, unless the CAA decides to reduce the period of validity for reasons of aviation safety.

AMC M.A.904 (a)(1) Airworthiness reviews of aircraft Imported into Maldives

In order to allow for possible participation of authority personnel, the applicant should inform the CAA at least 10 working days in advance of the time and location of the airworthiness review.

AMC M.A.904 (a)(2) Airworthiness reviews of aircraft Imported into Maldives

WORK TO BE UNDERTAKEN TO ESTABLISH AIRWORTHINESS

1. When performing an airworthiness review of aircraft imported, the aircraft and the relevant records should be reviewed to determine the work to be undertaken to establish the airworthiness of the aircraft.
2. In determining the work to be undertaken during the airworthiness review on the aircraft, the following should be taken into consideration:
 - (a) the information from exporting country authorities such as export certificates, primary

authority information;

- (b) the information on aircraft maintenance history such as continuing airworthiness records, aircraft, engine, propeller, rotor and life limited part log books or cards as appropriate, tech log/flight log/cabin log, list of deferred defects, total flight times and cycles, times and cycles since last maintenance, accident history, former maintenance schedule, former AD compliance status;
 - (c) the information on aircraft such as aircraft, engine and propeller type certificate datasheets, noise and emission certificate data sheets, flight manual and supplements;
 - (d) the aircraft continuing airworthiness status such as the aircraft and component AD status, the SB status, the maintenance status, the status of life-limited parts and time-controlled components, weight and centre of gravity schedule including equipment list;
 - (e) the modification and repair status of the aircraft detailing elements such as owner/operator designed modifications and repairs, STCs, and parts needing European Part Approval (EPA).
 - (f) the aircraft cabin configuration such as emergency equipment fitted, cockpit configuration, placards, instrument limitations, cabin layout;
 - (g) the maintenance needed for import, such as embodiment of modifications needed to comply with the type certificate, bridging check to comply with the new maintenance programme;
 - (h) the avionics such as, but not limited to, radio and navigation equipment, instrument flight rules (IFR) equipment, digital flight data recorder (DFDR)/cockpit voice recorder (CVR) test, emergency locator transmitter (ELT) 406 MHz code and identification;
 - (i) the compass compensation;
 - (j) special operating rules such as extended twin-engine operations (ETOPS)/long range operations (LROPS), reduced vertical separation minima (RVSM), minimum navigation performance specifications (MNPS), all weather operations (AWOPS), area navigation (RNAV);
 - (k) the aircraft survey including verification of conformity with the flight manual and the datasheet, presence of fire proof identification plates, conformity of markings including registration, presence and serviceability of emergency equipment, internal and external lighting systems, and
 - (l) maintenance check flight including check of control system/cockpit ground check/engine run up.
3. If there is no CAMO or maintenance organisation approved for the airworthiness review of the specific aircraft type available, the CAA may carry out the airworthiness review in accordance with this paragraph and the provisions M.A.901(g) and M.B.902. In this case, the airworthiness review should be requested to the CAA within a 30-day notice.

AMC M.A.904(b) Airworthiness review of imported aircraft

CONTENT OF RECOMMENDATION

The recommendation sent to the CAA should contain at least the items described below.

- (a) All the information set forth by AMC M.A 901(d)
- (b) Aircraft information
 - aircraft assigned registration;
 - state of manufacturer;
 - previous registration;
 - export certificate number;
 - TC and TC data sheet numbers;
 - noise and emissions TC and TC data sheet numbers;
 - comparison of prior maintenance programme with the proposed new maintenance programme.
- (c) Documents accompanying the recommendation
 - copy of the application;
 - original export certificate;
 - copy of the approvals of the flight manual and its supplements;
 - list of ADs incorporated up to the latest published issue;
 - proposed new maintenance programme;
 - status of all life-limited parts and time-controlled components;
 - the valid weight and centre of gravity schedule reflecting the current configuration of the aircraft, and;
 - MCAR-21 approval reference for all modifications and repairs.
- (d) Maintenance
 - a copy of the work packages requested by the CAMO including details of any bridging check to ensure all the necessary maintenance has been carried out.
- (e) Aircraft check flight
 - a copy of the check flight report

MCAR-M.A.905 Findings

- (a) A level 1 finding is any finding of significant non-compliance with MCAR-M requirements which lowers the safety standard and seriously endangers flight safety.
- (b) A level 2 finding is any finding of non-compliance with MCAR-M requirements, which may lower the safety standard and may endanger the flight safety.
- (c) After receipt of notification of findings according to point M.B.903, the person or organisation accountable referred to in point M.A.201 shall define a corrective action plan and demonstrate corrective action to the satisfaction of the CAA within a period agreed with the CAA including appropriate corrective action to prevent reoccurrence of the finding and its root cause.

Section B – PROCEDURES FOR THE CAA

SUBPART A — GENERAL

MCAR-M.B.101 Scope

This Section establishes the administrative procedures followed by the CAA in the implementation and enforcement of Section A of this Regulation.

MCAR-M.B.103 Findings and enforcement measure - persons

If, during oversight or by any other means, evidence is found by the CAA that shows a non-compliance with the applicable requirements by a person holding a licence, certificate, rating or attestation, the CAA will take any enforcement measures necessary to prevent the continuation of that non-compliance.

Subpart B — ACCOUNTABILITY

MCAR-M.B.201 Responsibilities

The CAA is responsible for conducting inspections and investigations in order to verify that the requirements of this Regulation are complied with.

SUBPART C — CONTINUING AIRWORTHINESS

MCAR-M.B.301 Aircraft maintenance programme

- (a) The CAA will verify that the AMP is in compliance with point M.A.302.
- (b) Unless stated otherwise in point (c) of point M.A.302, the AMP and its amendments will be approved directly by the CAA. The CAA should have access to all the data required by points (d), (e) and (f) of point M.A.302.
- (c) In the case of indirect approval as provided for in point M.A.302(c), the CAA will approve the AMP approval procedure of the CAO or CAMO through that organisation's exposition referred to in point MCAR-CAO.A.025, point M.A.704, or MCAR-CAMO.A.300, as applicable.

AMC M.B.301(b) Maintenance programme

If the CAA is no longer satisfied that a safe operation can be maintained, the approval of a maintenance programme or part of it may be suspended or revoked. Events giving rise to such action include:

- An operator changing the utilisation of an aircraft;
- The owner or CAMO has failed to ensure that the programme reflects the maintenance needs of the aircraft such that safe operation can be assured.

AMC M.B.301(c) Maintenance Programme

1. Approval of an aircraft maintenance programme through a procedure established by a CAO/CAMO should require the organisation to demonstrate to the CAA that it has competence, procedures and record keeping provisions, which will enable the organisation to analyse aircraft reliability, TC holder's instructions, and other related operating and maintenance criteria.
2. According to the complexity of the aircraft and the nature of the operation, the maintenance programme procedures should contain reliability centred maintenance and condition monitored maintenance programme procedures and have procedures relating to the programme control which contain the following provisions:
 - (a) task escalation or adjustment,
 - (b) maintenance programme review,
 - (c) SB or Service Information assessment,
 - (d) component and structures in service performance review,
 - (e) maintenance programme revision,
 - (f) maintenance procedure effectiveness review and amendment,
 - (g) maintenance review board report (MRBR) or manufacturer maintenance planning document (MPD) review and assessment, as appropriate,

- (h) AD review and assessment,
 - (i) owner/maintenance/CAO or CAMO liaison,
 - (j) training.
3. When the CAA requests it, the organisation should make provision for the attendance of a representative of the CAA at meetings held to consider maintenance implications arising from reviews of the above provisions.

MCAR-M.B.303 Aircraft continuing-airworthiness monitoring

- (a) The CAA has established a survey programme following a risk-based approach to monitor the airworthiness status of the fleet of aircraft on its register.
- (b) A survey programme includes sample product surveys of aircraft and covers all aspects of airworthiness key risk elements.
- (c) A sample product survey includes sampling of the airworthiness standards achieved, on the basis of the applicable requirements, and identify any findings.
- (d) Any findings identified will be categorised in accordance with point ML.B.903 and confirmed in writing to the person or organisation responsible pursuant to point M.A.201.
- (e) The CAA record all findings and closure actions.
- (f) If during aircraft monitoring, evidence is found showing non-compliance with this or other MCARs, the finding will be dealt with as provided for by the relevant MCAR.
- (g) (Reserved)

AMC1 M.B.303(a) Aircraft continuing airworthiness monitoring (ACAM)

ACAM SURVEY PROGRAMME — SCOPE

- 1. The CAA has established a programme covering in-depth surveys and ramp surveys.
- 2. The CAA's survey programme select aircraft and/or operators depending on the number and complexity of aircraft on the Maldivian civil aircraft register, the diversity of aircraft types, local knowledge of the maintenance environment and operating conditions, airworthiness standards and past surveillance experience.
- 3. The programme prioritise the operator/fleet/aircraft/key risk elements which are causing the greatest concern.
- 4. The survey programme also includes a certain percentage of unannounced ramp surveys.
- 5. (Reserved).

AMC3 M.B.303(b) Aircraft continuing airworthiness monitoring

KEY RISK ELEMENTS (KREs)

1. The following KREs will be used for aircraft continuing airworthiness monitoring:
 - (a) Type design and changes to type design
 - (b) Airworthiness limitations
 - (c) Airworthiness Directives
 - (d) Aircraft documents
 - (e) Flight Manual
 - (f) Mass & Balance
 - (g) Markings & placards
 - (h) Operational requirements
 - (i) Defect management
 - (j) Aircraft Maintenance Programme
 - (k) Component control
 - (l) Repairs
 - (m) Records

2. These KREs and their detailed components will be adapted to the complexity of the aircraft type being surveyed by retaining only those items that are applicable and relevant for the particular aircraft type.

MCAR-M.B.304 Revocation and suspension

The CAA will:

- (a) suspend an airworthiness review certificate on reasonable grounds in the case of potential safety threat, or;
- (b) suspend or revoke an airworthiness review certificate pursuant to M.B.903(1).

MCAR-M.B.305 Aircraft technical log system

- (a) The CAA will approve the initial aircraft technical log system required by point MCAR-M.A.306.
- (b) To enable the organisation to implement changes to the aircraft technical log system without prior CAA approval, the CAA may approve the relevant procedure referred to in point CAMO.A.300(c) or point M.A.704(c) of this Regulation or point CAO.A.025(c).

SUBPART F — MAINTENANCE ORGANISATION

MCAR-M.B.602 Initial Approval

- (a) Provided the requirements of points M.A.606(a) and (b) are complied with, the CAA will formally indicate its acceptance of the M.A.606(a) and (b) personnel to the applicant in writing.
- (b) The CAA will establish that the procedures specified in the maintenance organisation manual comply with Subpart F of MCAR-M, and shall ensure that the accountable manager signs the commitment statement.
- (c) The CAA will verify that the organisation is in compliance with the requirements laid down in Subpart F of this Regulation.
- (d) A meeting with the accountable manager will be convened at least once during the investigation for approval to ensure that he/she fully understands the significance of the approval and the reason for signing the commitment of the organisation to compliance with the procedures specified in the manual.
- (e) All findings will be confirmed in writing to the applicant organisation.
- (f) The CAA will record all findings, closure actions (actions required to close a finding) and recommendations.
- (g) For initial approval all findings shall be corrected by the organisation and closed by the CAA before the approval can be issued.

AMC M.B.602(a) Initial approval

1. 'Formally indicate in writing' means that an CAA/EASA Form 4 (Appendix X to AMC M.B.602(a) and AMC M.B.702(a)) will be used for this activity. With the exception of the accountable manager, CAA/EASA Form 4 should be completed for each person nominated to hold a position required by M.A.606(b).
2. In the case of the accountable manager approval of the maintenance organisation manual containing the accountable manager's signed commitment statement constitutes formal acceptance.

MCAR-M.B.603 Issue of approval

- (a) The CAA will issue to the applicant a CAA Form 3 approval certificate (Appendix V to this Regulation), which includes the extent of the approval, when the maintenance organisation is in compliance with the applicable points of this Regulation.
- (b) The CAA will indicate the conditions attached to the approval on the CAA Form 3 approval certificate.

AMC M.B.603(a) Issue of approval

1. (Reserved)

2. The approval should be based upon the organisational capability relative to M.A. Subpart F compliance and not limited by reference to individual CAA certificated products.

For example, if the organisation is capable of maintaining within the limitation of M.A. Subpart F the Cessna 100 series aircraft the approval schedule should state A2 Cessna 100 series and not Cessna 172RG which is a particular designator for one of many Cessna 100 series.

3. **Special case for ELA1 aircraft:**

In order to promote standardisation, for this category of aircraft the following approach is used:

- Possible ratings to be endorsed in CAA Form 3:
 - ELA1 sailplanes;
 - ELA1 powered sailplanes and ELA1 aeroplanes;
 - ELA1 balloons;
 - ELA1 airships.
- Before endorsing any of those ratings (for example, ELA1 sailplanes) in CAA Form 3, the CAA will audit that the organisation is capable of maintaining at least one aircraft type (for example, one type of sailplanes within the ELA1 category), including the availability of the necessary facilities, equipment, tooling, material, maintenance data, and certifying staff.
- It is acceptable that the detailed scope of work in the Maintenance Organisation Manual (MOM) contains the same ratings endorsed in CAA Form 3 (for example, ELA1 sailplanes), without a need to further limit them. However, the maintenance organisation will only be able to maintain a certain aircraft type when all the necessary facilities, equipment, tooling, material, maintenance data, and certifying staff are available.

MCAR-M.B.604 Continuing oversight

- (a) (Reserved).
- (b) Each organisation will be completely audited at periods not exceeding 24 months.
- (c) All findings will be confirmed in writing to the applicant organisation.
- (d) The CAA will record all findings, closure actions (actions required to close a finding) and recommendations.
- (e) A meeting with the accountable manager will be convened at least once every 24 months to ensure he/she remains informed of significant issues arising during audits.

AMC M.B.604(b) Continuing oversight

1. Where the CAA has decided that a series of audit visits are necessary to arrive at a complete audit of an approved maintenance organisation, the program will indicate which aspects of the approval will be covered on each visit.
2. Part of the audit may concentrate on the organisations internal self monitoring reports produced by the organisational review to determine if the organisation is identifying and correcting its problems.
3. At the successful conclusion of the audit(s) including verification of the manual, an audit report form should be completed by the auditing surveyor including all recorded findings, closure actions and recommendation. CAA Form 6F should be used for this activity.
4. Credit may be claimed by the CAA surveyor(s) for specific item audits completed during the preceding 23-month period subject to four conditions:
 - (a) the specific item audit should be the same as that required by M.A. Subpart F latest amendment, and
 - (b) there should be satisfactory evidence on record that such specific item audits were carried out and that all corrective actions have been taken, and
 - (c) the CAA surveyor(s) should be satisfied that there is no reason to believe standards have deteriorated in respect of those specific item audits being granted a back credit;
 - (d) the specific item audit being granted a back credit should be audited not later than 24 months after the last audit of the item.
5. When performing the oversight of an organisation that holds more than one approval pursuant to Maldives Civil Aviation Regulations, the CAA may arrange the audits to cover both approvals avoiding a duplicated visit of a particular area.

MCAR-M.B.605 Findings

- (a) When during audits or by other means evidence is found showing non-compliance with a requirement laid down in this Regulation or MCAR-ML, the CAA shall take the following actions:
 1. For level 1 findings, immediate action shall be taken by the CAA to revoke, limit or suspend in whole or in part, depending upon the extent of the level 1 finding, the maintenance organisation approval, until successful corrective action has been taken by the organisation.
 2. For level 2 findings, the CAA shall grant a corrective action period appropriate to the nature of the finding that shall not be more than three months. In certain circumstances, at the end of this first period and subject to the nature of the finding, the CAA can extend the three month period subject to a satisfactory corrective action plan.
- (b) Action shall be taken by the CAA to suspend in whole or part the approval in case of failure to comply within the timescale granted by the CAA.

AMC M.B.605(a)(1) Findings

For a level 1 finding it may be necessary for the CAA to ensure that further maintenance and re-certification of all affected products is accomplished, dependent upon the nature of the finding.

MCAR-M.B.606 Changes

- (a) The CAA will comply with the applicable elements of the initial approval for any change to the organisation notified in accordance with point M.A.617.
- (b) The CAA may prescribe the conditions under which the approved maintenance organisation may operate during such changes, unless it determines that the approval should be suspended due to the nature or the extent of the changes.
- (c) For any change to the maintenance organisation manual:
 - 1. in the case of direct approval of changes in accordance with point (b) of point M.A.604, the CAA will verify that the procedures specified in the manual are in compliance with this Regulation before formally notifying the approved organisation of the approval;
 - 2. in the case of an indirect approval of changes in accordance with point (c) of point M.A.604, the CAA will ensure that:
 - (i) the changes remain minor;
 - (ii) it has adequate control over the approval of the changes to ensure they remain in compliance with the requirements of this Regulation.

MCAR-M.B.607 Revocation, suspension and limitation of an approval

The CAA will:

- (a) suspend an approval on reasonable grounds in the case of potential safety threat, or;
- (b) suspend, revoke or limit an approval pursuant to point M.B.605.

SUBPART G — CONTINUING AIRWORTHINESS MANAGEMENT ORGANISATION

MCAR-M.B.701 Application

- (a) For licenced air carriers the CAA should receive for approval with the initial application for the air operator's certificate and where applicable any variation applied for and for each aircraft type to be operated:
1. the continuing airworthiness management exposition;
 2. the operator's aircraft maintenance programmes;
 3. the aircraft technical log;
 4. where appropriate the technical specification of the maintenance contracts between the CAMO and MCAR-145 approved maintenance organisation.

AMC M.B.701(a) Application

1. The documents listed in M.B.701(a) points (1), (2) and (3) may require approval. Draft documents should be submitted at the earliest opportunity so that assessment of the application can begin. Grant or change cannot be effected until the CAA has received the completed documents. This information is required to enable the CAA to conduct its assessment in order to determine the volume of oversight work necessary and the locations at which it will be accomplished.
2. If considered appropriate for the assessment, the CAA may request that at the time of initial application or change of the approval schedule the CAMO applicant provides a copy of the technical specifications of the contracts with MCAR-145 organisations to demonstrate that arrangements are in place for all base and scheduled line maintenance for an appropriate period of time.

MCAR-M.B.702 Initial approval

- (a) Provided the requirements of points M.A.706(a), (c), (d) and M.A.707 are complied with, the CAA will formally indicate its acceptance of the M.A.706(a), (c), (d) and M.A.707 personnel to the applicant in writing.
- (b) The CAA will establish that the procedures specified in the continuing airworthiness management exposition comply with Section A, Subpart G of this Regulation and ensure the accountable manager signs the commitment statement.
- (c) The CAA will verify the organisation's compliance with requirements laid down in Section A, Subpart G of this Regulation.
- (d) A meeting with the accountable manager will be convened at least once during the investigation for approval to ensure that he/she fully understands the significance of the approval and the reason for signing the exposition commitment of the organisation to compliance with the procedures specified in the continuing airworthiness management exposition.
- (e) All findings shall be confirmed in writing to the applicant organisation.

- (f) The CAA will record all findings, closure actions (actions required to close a finding) and recommendations.
- (g) For initial approval all findings shall be corrected by the organisation and closed by the CAA before the approval can be issued.

AMC M.B.702(a) Initial approval

1. 'Formally indicate in writing' means that a CAA Form 4 (Appendix X to AMC M.B.602(a) and AMC M.B.702(a)) should be used for this activity. With the exception of the accountable manager, a CAA Form 4 should be completed for each person nominated to hold a position required by M.A.706(c), (d) and M.A.707.
2. In the case of the accountable manager, approval of the continuing airworthiness management exposition containing the accountable manager's signed commitment statement constitutes formal acceptance, once the CAA has held a meeting with the accountable manager and is satisfied with its results.

AMC M.B.702(b) Initial approval

1. The CAA will indicate approval of the continuing airworthiness management exposition in writing.
2. Contracts for sub-contracting continuing airworthiness management tasks by CAMOs should be included in the continuing airworthiness organisation exposition. The CAA will verify that the standards set forth in AMC M.A.711(a)(3) have been met when approving the exposition.
3. The CAA while investigating the acceptability of the proposed subcontracted continuing airworthiness management tasks arrangements will take into account, in the subcontracted organisation, all other such contracts that are in place irrespective of state of registry in terms of sufficiency of resources, expertise, management structure, facilities and liaison between the CAMO, the subcontracted organisation and, where applicable, the contracted maintenance organisation(s).

AMC M.B.702(c) Initial approval

1. The CAA will determine by whom, and how the audit shall be conducted. For example, it will be necessary to determine whether one large team audit or a short series of small team audits or a long series of single man audits are most appropriate for the particular situation.
2. The audit may be carried out on a product line type basis. For example, in the case of an organisation with Airbus A320 and Airbus A310 ratings, the audit is concentrated on one type only for a full compliance check. Dependent upon the result, the second type may only require a sample check that should at least cover the activities identified as weak for the first type.
3. When determining the scope of the audit and which activities of the organisation will be assessed during the audit, the privileges of the approved organisation should be taken into account, e.g. approval to carry out airworthiness reviews.
4. The CAA surveyor will always ensure that he/she is accompanied throughout the audit by a senior technical member of the organisation. Normally this is the quality manager. The reason for being accompanied is to ensure the organisation is fully aware of any findings during the audit.

5. The surveyor will inform the senior technical member of the organisation at the end of the audit visit on all findings made during the audit.

AMC M.B.702(e) Initial approval

1. Findings will be recorded on an audit report form with a provisional categorisation as a level 1 or 2. Subsequent to the audit visit that identified the particular findings, the CAA will review the provisional finding levels, adjusting them if necessary and change the categorisation from 'provisional' to 'confirmed'.
2. All findings will be confirmed in writing to the applicant organisation within 20 working days of the audit visit.
3. There may be occasions when the CAA finds situations in the applicant's organisation on which it is unsure about compliance. In this case, the organisation should be informed about possible non-compliance at the time and the fact that the situation will be reviewed within the CAA before a decision is made. If the review concludes that there is no finding then a verbal confirmation to the organisation will suffice.

MCAR-M.B.703 Issue of approval

- (a) The CAA will issue to the applicant a CAA Form 14-MG approval certificate (Appendix VI to this Regulation) which includes the extent of approval, when the continuing airworthiness management organisation is in compliance with Section A, Subpart G of this Regulation.
- (b) The CAA will indicate the validity of the approval on the CAA Form 14-MG approval certificate.
- (c) (Reserved).
- (d) In the case of licenced air carriers, the information contained on CAA Form 14-MG will be included on the air operator's certificate.

AMC M.B.703 Issue of approval

The table shown for the Approval Schedule in CAA Form 14 includes a field designated as 'Aircraft type/series/group'

Possible alternatives to be included in this field are the following:

- A specific type designation that is part of a type certificate, such as Airbus 340-211 or Cessna 172R.
- A type rating (or series) as listed in MCAR-66 Appendix I to AMC, which may be further subdivided, such as Boeing 737-600/700/800, Boeing 737-600, Cessna 172 Series.
- An aircraft group such as, for example, 'all sailplanes and powered sailplanes' or 'Cessna single piston engined aircraft' or 'Group 3 aircraft' (as defined in 66.A.5) or 'aircraft below 2 730 kg MTOM'.

Reference to the engine type installed in the aircraft may or may not be included, as necessary.

It is important to note that the scope of work defined in CAA Form 14 is further limited to the one defined in the Continuing Airworthiness Management Exposition (CAME). It is this scope of work in the CAME which ultimately defines the approval of the organisation. As a consequence, it is possible for the CAA to endorse in CAA Form 14, for example, a scope of work for Group 3 aircraft while the detailed scope of work defined in the CAME does not include all Group 3 aircraft.

Nevertheless, in all cases, the CAA must be satisfied that the organisation has the capability to manage the types/groups/series endorsed in the CAA Form 14.

Since the activities linked to continuing airworthiness management are mainly process-oriented rather than facility/tooling-oriented, changes to the detailed scope of work defined in the CAME (either directly or through a capability list), within the limits already included in CAA Form 14, may be considered as not affecting the approval and not subject to M.A.713. As a consequence, for these changes the CAA may allow the use by the CAMO of the indirect approval procedure defined in M.A.704(c).

In the example mentioned above, before endorsing the Group 3 in CAA Form 14 for the first time, the CAA will make sure that the organisation is capable of managing this category of aircraft as a whole. In particular, the CAA will ensure that Baseline/Generic Maintenance Programmes (see M.A.709) or individual maintenance programmes (for contracted customers) are available for all the aircraft which are intended to be initially included in the scope of work detailed in the CAME. Later on, if changes need to be introduced in the detailed scope of work detailed in the CAME to include new aircraft types (within Group 3), this may be done by the CAMO through the use of the indirect approval procedure.

Since, as mentioned above, the CAA will make sure that the organisation is capable of managing the requested category as a whole, it is not reasonable to grant a full Group 3 approval based on an intended scope of work which is limited to, for example, a Cessna 172 aircraft. However, it may be reasonable to grant such full Group 3 approval, after showing appropriate capability, for an intended scope of work covering several aircraft types or series of different complexity and which are representative of the full Group 3.

Special case for ELA1 aircraft:

In order to promote standardisation, for this category of aircraft the following approach is recommended:

- Possible ratings to be endorsed in CAA Form 14:
 - ELA1 sailplanes;
 - ELA1 powered sailplanes and ELA1 aeroplanes;
 - ELA1 balloons;
 - ELA1 airships.
- Before endorsing any of those ratings (for example, ELA1 sailplanes) in CAA Form 14, the CAA will audit that the organisation is capable of managing at least one aircraft type (for example, one type of sailplanes within the ELA1 category), including the availability of the necessary facilities, data, maintenance programmes, and staff.
- It is acceptable that the detailed scope of work in the CAME contains the same ratings endorsed in CAA Form 14 (for example, ELA1 sailplanes), without a need to further limit them. However, the

CAMO will only be able to manage a certain aircraft type when all the necessary facilities, data, maintenance programmes and staff are available.

MCAR-M.B.704 Continuing oversight

- (a) (Reserved).
- (b) Each organisation will be completely audited at periods not exceeding 24 months.
- (c) A relevant sample of the aircraft managed by the organisation approved under Section B, Subpart G of this Regulation will be surveyed in every 24 month period. The size of the sample will be decided by the CAA based on the result of prior audits and earlier product surveys.
- (d) All findings will be confirmed in writing to the applicant organisation.
- (e) The CAA will record all findings, closure actions (actions required to close a finding) and recommendations.
- (f) A meeting with the accountable manager will be convened at least once every 24 months to ensure he/she remains informed of significant issues arising during audits.

AMC M.B.704(b) Continuing oversight

1. Where the CAA has decided that a series of audit visits are necessary to arrive at a complete audit of an approved continuing airworthiness management organisation, the program will indicate which aspects of the approval will be covered on each visit.
2. Part of an audit may concentrate on two ongoing aspects of the M.A. Subpart G approval, namely the organisations internal self monitoring quality reports produced by the quality monitoring personnel to determine if the organisation is identifying and correcting its problems and secondly the number of concessions granted by the quality manager.
3. (Reserved).
4. Credit may be claimed by the CAA surveyor(s) for specific item audits completed during the preceding 23 month period subject to four conditions:
 - (a) the specific item audit should be the same as that required by M.A. Subpart G latest amendment, and
 - (b) there should be satisfactory evidence on record that such specific item audits were carried out and that all corrective actions have been taken, and
 - (c) the CAA surveyor(s) should be satisfied that there is no reason to believe standards have deteriorated in respect of those specific item audits being granted a back credit;
 - (d) the specific item audit being granted a back credit should be audited not later than 24 months after the last audit of the item.
5. When a CAMO sub-contracts continuing airworthiness management tasks all sub-contracted organisations will also be audited by the CAA at periods not exceeding 24 months (credits per

paragraph 4 above are permitted) to ensure they fully comply with M.A. Subpart G. For these audits, the CAA auditing surveyor should always ensure that he/she is accompanied throughout the audit by a senior technical member of the CAMO. All findings should be sent to and corrected by the CAMO.

6. When performing the oversight of organisations that hold various approvals, the CAA will arrange the audits to cover all approvals avoiding a duplicated visit of a particular area.

MCAR-M.B.705 Findings

(a) When during audits or by other means, evidence is found showing non-compliance to a requirement laid down in this Regulation or MCAR-ML, as applicable, the CAA will take the following actions:

1. For level 1 findings, immediate action will be taken by the CAA to revoke, limit or suspend in whole or in part, depending upon the extent of the level 1 finding, the continuing airworthiness management organisation approval, until successful corrective action has been taken by the organisation.
2. For level 2 findings, the CAA will grant a corrective action period appropriate to the nature of the finding that will not be more than three months. In certain circumstances, at the end of this first period, and subject to the nature of the finding the CAA can extend the three month period subject to a satisfactory corrective action plan.

(b) Action will be taken by the CAA to suspend in whole or part the approval in case of failure to comply within the timescale granted by the CAA.

AMC M.B.705(a)(1) Findings

For a level 1 finding the CAA will inform the owner/operator of any potentially affected aircraft in order that corrective action can be taken to ensure possible unsafe conditions on these aircraft are corrected before further flight.

Furthermore, a level 1 finding could lead to a non-compliance to be found on an aircraft as specified in M.B.303(f).

MCAR-M.B.706 Changes

(a) The CAA will ensure compliance with the applicable elements of the initial approval for any change to the organisation notified in accordance with point M.A.713.

(b) The CAA may prescribe the conditions under which the approved continuing airworthiness management organisation may operate during such changes unless it determines that the approval should be suspended due to the nature or the extent of the changes.

(c) For any change to the continuing airworthiness management exposition:

1. In the case of direct approval of changes in accordance with point M.A.704(b) of this Regulation, the CAA will verify that the procedures specified in the exposition are in compliance with this Regulation or MCAR-ML, as applicable, before formally notifying the approved organisation of the approval.

2. In the case an indirect approval procedure is used for the approval of the changes in accordance with point M.A.704(c) of this Regulation, the CAA will ensure all of the following:
 - (i) that the changes remain minor;
 - (ii) that it has an adequate control over the approval of the changes to ensure they remain in compliance with the requirements of this Regulation or MCAR-ML, as applicable.

AMC M.B.706 Changes

1. Changes in nominated persons specified in M.A.706(a), (c), (d) and (i) will require an amendment to the exposition.
2. (Reserved).
3. The CAA will define the minor amendments to the exposition which may be incorporated through indirect approval. In this case a procedure should be stated in the amendment section of the approved continuing airworthiness management exposition.
4. Changes notified in accordance with M.A.713 are not considered minor.
5. The CAMO should submit each exposition amendment to the CAA whether it be an amendment for CAA approval or an indirectly approved amendment. Where the amendment requires CAA approval, the CAA when satisfied, will indicate its approval in writing. Where the amendment has been submitted under the indirect approval procedure the CAA will acknowledge receipt in writing.

MCAR-M.B.707 Revocation, suspension and limitation of an approval

The CAA will:

- (a) suspend an approval on reasonable grounds in the case of potential safety threat, or;
- (b) suspend, revoke or limit an approval pursuant to point M.B.705.

(Subpart H – RESERVED)

SUBPART I — AIRWORTHINESS REVIEW CERTIFICATE

MCAR-M.B.901 Assessment of recommendations

Upon receipt of an application and associated airworthiness review certificate recommendation in accordance with point M.A.901:

1. Appropriately qualified personnel of the CAA will verify that the compliance statement contained in the recommendation demonstrates that a complete airworthiness review in accordance with point M.A.901 has been carried out.
2. The CAA will investigate and may request further information to support the assessment of the recommendation.

AMC M.B.901 Assessment of recommendations

1. The result of the verification and the investigation of a recommendation will be sent to the applicant within 30 days. If corrective action has been requested before the issuance of an airworthiness review certificate, the CAA may decide a further period for the assessment of the requested corrective action.
2. The verification of the compliance statement required by M.B.901 does not mean repeating the airworthiness review itself. However, the CAA will verify that the CAMO/CAO has carried out a complete and accurate assessment of the airworthiness of the aircraft.
3. Depending on the content of the recommendation, the history of the particular aircraft, and the knowledge of the CAMO/CAO making the recommendation in terms of experience, number and correction of findings and previous recommendations, the extent of the investigation will vary. Therefore, whenever possible the person carrying out the investigation should be involved in the oversight of the CAMO/CAO making the recommendation.
4. In some cases, the inspector may decide that it is necessary to organise:
 - a physical survey of the aircraft, or
 - a full or partial airworthiness review.

In this case, the inspector should inform the CAMO/CAO making the recommendation with sufficient notice so that it may organise itself according to M.A.901(i).

5. Only when satisfied that the aircraft is airworthy, should the inspector issue an airworthiness review certificate.

MCAR-M.B.902 Airworthiness review by the competent authority

- (a) When the CAA carries out the airworthiness review and issues the airworthiness review certificate (Appendix III (CAA Form 15a) to this Regulation), the CAA will carry out an airworthiness review in accordance with point M.A.901.
- (b) The CAA will issue a Form 15a after satisfactory completion of the airworthiness review.

MCAR-M.B.903 Findings

If during aircraft surveys or by other means evidence is found showing non-compliance to a MCAR-M requirement, the CAA will take the following actions:

1. for level 1 findings, the CAA will require appropriate corrective action to be taken before further flight and immediate action shall be taken by the CAA to revoke or suspend the airworthiness review certificate.
2. for level 2 findings, the corrective action required by the CAA will be appropriate to the nature of the finding.

APPENDICES TO THE REGULATIONS

Appendix I Continuing Airworthiness Management Contract

1. When an owner or operator contracts in accordance with M.A.201 a CAMO or CAO to carry out continuing airworthiness management tasks, upon request by the CAA, a copy of the contract signed by both parties shall be sent by the owner or operator to the CAA.
2. The contract shall be developed taking into account the requirements of this Regulation and shall define the obligations of the signatories in relation to the continuing airworthiness of the aircraft.
3. It shall contain as a minimum the following information:
 - aircraft registration, type and serial number;
 - aircraft owner or registered lessee's name or company details including the address,
 - details of the contracted CAMO or CAO, including the address and
 - The Type of operation

4. It shall state the following:

"The owner or operator entrusts the CAMO or CAO with the management of the continuing airworthiness of the aircraft, including but not limited to the development of an AMP that shall be approved by the CAA, and the organisation of the maintenance of the aircraft according to said AMP.

According to the present contract, both signatories undertake to follow the respective obligations of this contract.

The owner or operator declares to the best of their knowledge that all the information given to the CAMO or CAO concerning the continuing airworthiness of the aircraft is and will continue to be accurate, and that the aircraft will not be repaired or modified without prior agreement of the CAMO or CAO.

In case of any non-conformity with this contract, by either of the signatories, the CAMO or CAO and the owner or operator shall assess if it impacts the continuation of the contract and shall inform the CAA. The assessment carried out by the organisations shall consider the safety significance of the non-conformity and if it is of repetitive nature. If either of the signatories concludes after this assessment that they cannot fulfil their responsibilities due to their own limitations or due to the failures of the signatory, the contract shall be cancelled and the CAA shall be informed immediately. In such a case, the owner or operator will retain full responsibility for every task linked to the continuing airworthiness of the aircraft, and the owner or operator will inform the CAA within 2 weeks about such non-conformity with the contract. In the case of contract concluded in accordance with M.A.201(ea), the CAA shall be informed immediately"

5. When an owner or operator contracts a CAMO or CAO in accordance with point M.A.201, the contract shall specify the obligations of each party as follows:
 - 5.1 Obligations of the CAMO or CAO:
 1. have the aircraft type included in its term of approval;
 2. respect the conditions listed below with regard to maintaining the continuing airworthiness

of the aircraft:

- (a) develop an AMP for the aircraft, including any reliability programme developed, if applicable;
 - (b) declare the maintenance tasks (in the AMP) that may be carried out by the pilot-owner in accordance with point M.A.803(c);
 - (c) organise the approval of the AMP ;
 - (d) once it has been approved, provide the owner or operator with a copy of the AMP;
 - (e) establish and order the necessary maintenance to ensure an appropriate bridging with the former aircraft maintenance programme;
 - (f) organise for all maintenance to be carried out by an approved maintenance organisation;
 - (g) organise for all applicable Ads to be applied;
 - (h) organise for all defects discovered during scheduled maintenance, airworthiness reviews or reported by the owner to be rectified by an approved maintenance organisation;
 - (i) coordinate the accomplishment of scheduled maintenance, including inspection of components, replacement of life-limited parts and the accomplishment of any applicable AD, and ensure compliance with operational requirements having a continuing airworthiness impact, continuing airworthiness requirements established by the State of Design and measures required by the CAA in immediate reaction to a safety problem;
 - (j) inform the owner or operator each time the aircraft is to be brought to an approved maintenance organisation;
 - (k) manage and archive the aircraft continuing airworthiness records;
 - (l) coordinate with the operator or owner on any request to the CAA for any deviation from the aircraft maintenance programme;
 - (m) support the operator or pilot-owner as regards the aircraft continuing airworthiness when they conduct maintenance check flights.
3. organise the approval of any modification to the aircraft in accordance with MCAR-21 before it is embodied;
 4. organise the approval of any repair to the aircraft in accordance MCAR-21 before it is carried out;
 5. inform the CAA whenever the aircraft is not presented to the approved maintenance organisation by the owner as requested by the approved organisation;
 6. inform the CAA whenever the present contract is not respected;

7. ensure that the airworthiness review of the aircraft is carried out when necessary, and ensure that the airworthiness review certificate is issued or a recommendation is sent to the CAA;
8. send within 10 days a copy of any airworthiness review certificate issued or extended to the CAA;
9. carry out all occurrence reporting mandated by applicable regulations;
10. inform the CAA whenever the present contract is denounced by either party.

5.2 Obligations of the owner/operator:

1. have a general understanding of the approved AMP;
2. have a general understanding of this Regulation;
3. present the aircraft to the approved maintenance organisation agreed with the CAMO or CAO at the due time designated at the CAMO's or CAO's request;
4. not modify the aircraft without first consulting the CAMO or CAO;
5. inform the CAMO or CAO of all maintenance exceptionally carried out without the knowledge and control of the CAMO or CAO;
6. report all defects found during operations to the CAMO or CAO through the logbook;
7. inform the CAA whenever the present contract is denounced by either party;
8. inform the CAA and CAMO or CAO whenever the aircraft is sold;
9. carry out all occurrence reporting mandated by applicable regulations;
10. inform on a regular basis the CAMO or CAO about the aircraft flying hours and any other utilisation data, as agreed with the CAMO or CAO;
11. enter the CRS in the logbooks as mentioned in point M.A.803(d) when performing pilot-owner maintenance without exceeding the limits of the maintenance tasks list as declared in the approved AMP as laid down in point M.A.803(c);
12. inform the CAMO or CAO not later than 30 days after completion of any pilot-owner maintenance task in accordance with point M.A.305(a).
13. ensure compliance with the approved maintenance programme and coordinate with the CAMO or CAO on any request to the CAA for any one-time extension to a maintenance programme interval;
14. inform the CAMO or CAO of any non-compliance with operational requirements that may affect the continuing airworthiness of the aircraft;
15. inform the CAMO or CAO of any operational requirement (e.g. specific approvals) necessary to be fulfilled in order to maintain the aircraft in the required configuration.

6. When an owner or operator contracts a CAMO or CAO in accordance with point M.A.201, the obligations of each party in respect of mandatory and voluntary occurrence reporting in accordance with MCAR-13B shall be clearly specified.

7. Additional requirements in the case of applying point M.A.201(ea)

In addition to the above-listed requirements and obligations in points 5.1 and 5.2, when a contract between the CAMO and the operator is concluded in accordance with point M.A.201(ea), the continuing airworthiness management contract shall also comply with the requirements of points 7.1 to 7.3.

Before the contract is signed, the operator shall assess the CAMO to ensure that the CAMO has the capability and capacity to comply with the contract.

7.1 Eligibility

The continuing airworthiness contract in accordance with M.A.201(ea) shall only be concluded if the air carrier concerned is licensed in accordance with Regulation (EC) No 1008/2008 and the CAMO forms part of the same air carrier business grouping. The continuing airworthiness management contract shall contain a clear description of how the conditions described in M.A.201(ea) are met. It shall in particular describe how the individual management systems of the organisations are harmonised between each other.

7.2 Additional obligations of the CAMO:

1. become knowledgeable about the operator's procedure related to the monitoring of the contract;
2. obtain the agreement from the operator before subcontracting continuing airworthiness tasks;
3. inform immediately the CAA whenever the aircraft is not presented to the approved maintenance organisation by the operator as requested by the CAMO, when the present contract is not respected or when the contract is denounced by either party;
4. provide training for the operator's staff to ensure that they have an understanding of the CAMO's:
 - (a) policies and procedures, responsibilities, obligations, duties and areas of interface;
 - (b) lines of communication (for example aircraft records, exchange of accurate airworthiness information in a timely manner including outside of normal working hours);
 - (c) procedures pertaining specifically to the CAMO such as customised software utilisation, reliability monitoring, use of the aircraft technical log system, and interoperability provisions.

7.3. Additional obligations of the operator:

1. develop interface procedures with the CAMO to address the issue and renewal of the airworthiness review certificate;

2. in case of unexpected maintenance needs in locations where no maintenance organisation approved in accordance with MCAR-145 is contracted, inform immediately the CAMO;
3. inform immediately the CAA whenever the contract is denounced by either party;
4. provide training for the CAMO staff in order to ensure that they have an understanding of the operator's:
 - (a) policies and procedures, responsibilities, obligations, duties and areas of interface;
 - (b) lines of communication;
 - (c) procedures pertaining specifically to the operator such as operational procedures, customised software utilisation, use of the aircraft technical log system, and interoperability provisions.

GM to Appendix I to MCAR-M - "Continuing airworthiness management contract"

An operator should establish adequate coordination between flight operations and the CAO/CAMO to ensure that both will receive all the necessary information on the condition of the aircraft to enable them perform their tasks.

Appendix II Authorised Release Certificate - CAA Form 1

These instructions relate only to the use of the CAA Form 1 for maintenance purposes. Attention is drawn to MCAR-21 which covers the use of the CAA Form 1 for production purposes.

1. PURPOSE AND USE

- 1.1. The primary purpose of the Certificate is to declare the airworthiness of maintenance work undertaken on products, parts and appliances (hereafter referred to as 'item(s)').
- 1.2. Correlation must be established between the Certificate and the item(s). The originator must retain a Certificate in a form that allows verification of the original data.
- 1.3. The Certificate is acceptable to many airworthiness authorities, but may be dependent on the existence of bilateral agreements and/or the policy of the airworthiness authority. The 'approved design data' mentioned in this Certificate then means approved by the airworthiness authority of the importing country.
- 1.4. The Certificate is not a delivery or shipping note.
- 1.5. Aircraft are not to be released using the Certificate.
- 1.6. The Certificate does not constitute approval to install the item on a particular aircraft, engine, or propeller but helps the end user determine its airworthiness approval status.
- 1.7. A mixture of production released and maintenance released items is not permitted on the same Certificate.

2. GENERAL FORMAT

- 2.1. The Certificate must comply with the format attached including block numbers and the location of each block. The size of each block may however be varied to suit the individual application, but not to the extent that would make the Certificate unrecognisable.
- 2.2. The Certificate must be in 'landscape' format but the overall size may be significantly increased or decreased so long as the Certificate remains recognisable and legible. If in doubt consult the CAA.
- 2.3. The User/Installer responsibility statement can be placed on either side of the form.
- 2.4. All printing must be clear and legible to permit easy reading.
- 2.5. The Certificate may either be pre-printed or computer generated but in either case the printing of lines and characters must be clear and legible and in accordance with the defined format.
- 2.6. The Certificate should be in English, and if appropriate, in one or more other languages.
- 2.7. The details to be entered on the Certificate may be either machine/computer printed or hand-written using block letters and must permit easy reading.
- 2.8. Limit the use of abbreviations to a minimum, to aid clarity.

- 2.9. The space remaining on the reverse side of the Certificate may be used by the originator for any additional information but must not include any certification statement. Any use of the reverse side of the Certificate must be referenced in the appropriate block on the front side of the Certificate.

3. COPIES

- 3.1. There is no restriction in the number of copies of the Certificate sent to the customer or retained by the originator.

4. ERROR(S) ON A CERTIFICATE

- 4.1. If an end-user finds an error(s) on a Certificate, he must identify it/them in writing to the originator. The originator may issue a new Certificate only if the error(s) can be verified and corrected.
- 4.2. The new Certificate must have a new tracking number, signature and date.
- 4.3. The request for a new Certificate may be honoured without re-verification of the item(s) condition. The new Certificate is not a statement of current condition and should refer to the previous Certificate in block 12 by the following statement; "This Certificate corrects the error(s) in block(s) [enter block(s) corrected] of the Certificate [enter original tracking number] dated [enter original issuance date] and does not cover conformity/condition/release to service". Both Certificates should be retained according to the retention period associated with the first.

5. COMPLETION OF THE CERTIFICATE BY THE ORIGINATOR

Block 1 Approving Competent Authority/Country

Enter "Maldives Civil Aviation Authority".

Block 2 CAA Form 1 header

"AUTHORISED RELEASE CERTIFICATE CAA FORM 1"

Block 3 Form Tracking Number

Enter the unique number established by the numbering system/procedure of the organisation identified in block 4; this may include alpha/numeric characters.

Block 4 Organisation Name and Address

Enter the full name and address of the approved organisation (refer to CAA form 3) releasing the work covered by this Certificate. Logos, etc., are permitted if the logo can be contained within the block.

Block 5 Work Order/Contract/Invoice

To facilitate customer traceability of the item(s), enter the work order number, contract number, invoice number, or similar reference number.

Block 6 Item

Enter line item numbers when there is more than one line item. This block permits easy cross-referencing to the Remarks block 12.

Block 7 Description

Enter the name or description of the item. Preference should be given to the term used in the instructions for continued airworthiness or maintenance data (e.g. Illustrated Parts Catalogue, Aircraft Maintenance Manual, Service Bulletin, Component Maintenance Manual).

Block 8 Part Number

Enter the part number as it appears on the item or tag/package. In case of an engine or propeller the type designation may be used.

Block 9 Quantity

State the quantity of items.

Block 10 Serial Number

If the item is required by regulations to be identified with a serial number, enter it here. Additionally, any other serial number not required by regulation may also be entered. If there is no serial number identified on the item, enter "N/A".

Block 11 Status/Work

The following describes the permissible entries for block 11. Enter only one of these terms – where more than one may be applicable, use the one that most accurately describes the majority of the work performed and/or the status of the article.

(i)	Overhauled	Means a process that ensures the item is in complete conformity with all the applicable service tolerances specified in the type certificate holder's, or equipment manufacturer's instructions for continued airworthiness, or in the data which is approved or accepted by the Authority. The item will be at least disassembled, cleaned, inspected, repaired as necessary, reassembled and tested in accordance with the above specified data.
(ii)	Repaired	Rectification of defect(s) using an applicable standard (1).
(iii)	Inspected/Tested	Examination, measurement, etc. in accordance with an applicable standard (1) (e.g. visual inspection, functional testing, bench testing etc.).
(iv)	Modified	Alteration of an item to conform to an applicable standard (1).
(1) Applicable standard means a manufacturing/design/maintenance/quality standard, method, technique, or practice approved by or acceptable to the CAA. The applicable standard shall be described in block 12.		

Block 12 Remarks

Describe the work identified in Block 11, either directly or by reference to supporting documentation, necessary for the user or installer to determine the airworthiness of item(s) in

relation to the work being certified. If necessary, a separate sheet may be used and referenced from the main CAA Form 1. Each statement must clearly identify which item(s) in Block 6 it relates to.

Examples of information to be entered in block 12 are:

- (i) Maintenance data used, including the revision status and reference.
- (ii) Compliance with airworthiness directives or service bulletins.
- (iii) Repairs carried out.
- (iv) Modifications carried out.
- (v) Replacement parts installed.
- (vi) Life limited parts status.
- (vii) Deviations from the customer work order.
- (viii) Release statements to satisfy a foreign Civil Aviation Authority maintenance requirement.
- (ix) Information needed to support shipment with shortages or re-assembly after delivery.
- (x) For maintenance organisations approved in accordance with Subpart F of this Regulation or MCAR-CAO, the component certificate of release to service statement referred to in point M.A.613 and CAO.A.070, as applicable: :

“Certifies that, unless otherwise specified in this block, the work identified in block 11 and described in this block was accomplished in accordance with the requirements of Section A, Subpart F of MCAR-M or MCAR-CAO, and in respect to that work the item is considered ready for release to service. THIS IS NOT A RELEASE UNDER MCAR-145.”

If printing the data from an electronic CAA Form 1, any appropriate data not fit for other blocks should be entered in this block.

Block 13a-13e

General Requirements for blocks 13a-13e: Not used for maintenance release. Shade, darken, or otherwise mark to preclude inadvertent or unauthorised use.

Block 14a

Mark the appropriate box(es) indicating which regulations apply to the completed work. If the box “other regulations specified in block 12” is marked, then the regulations of the other airworthiness authority(ies) must be identified in block 12. At least one box must be marked, or both boxes may be marked, as appropriate.

For all maintenance carried out by maintenance organisations approved in accordance with Section A, Subpart F of this Regulation or MCAR-CAO, the box “other regulation specified in block 12” shall be ticked and the CRS statement made in block 12. In that case, the certification statement “unless otherwise specified in this block” is intended to address the following cases;

- (a) Where the maintenance could not be completed.
- (b) Where the maintenance deviated from the standard required by MCAR-M or MCAR-CAO.
- (c) Where the maintenance was carried out in accordance with a requirement other than that specified in MCAR-M or MCAR-CAO. In this case block 12 shall specify the particular regulation.

For all maintenance carried out by maintenance organisations approved in accordance with Section A of MCAR-145, the certification statement “unless otherwise specified in block 12” is intended to address the following cases;

- (a) Where the maintenance could not be completed.
- (b) Where the maintenance deviated from the standard required by MCAR-145.
- (c) Where the maintenance was carried out in accordance with a requirement other than that specified in MCAR-145. In this case block 12 shall specify the particular regulation.

Block 14b Authorised Signature

This space shall be completed with the signature of the authorised person. Only persons specifically authorised under the rules and policies of the CAA are permitted to sign this block. To aid recognition, a unique number identifying the authorised person may be added.

Block 14c Certificate/Approval Number

Enter the Certificate/Approval number/reference. This number or reference is issued by the CAA.

Block 14d Name

Enter the name of the person signing block 14b in a legible form.

Block 14e Date

Enter the date on which block 14b is signed, the date must be in the format dd = 2 digit day, mmm = first 3 letters of the month, yyyy = 4 digit year

User/Installer Responsibilities

Place the following statement on the Certificate to notify end users that they are not relieved of their responsibilities concerning installation and use of any item accompanied by the form:

“THIS CERTIFICATE DOES NOT AUTOMATICALLY CONSTITUTE AUTHORITY TO INSTALL.

WHERE THE USER/INSTALLER PERFORMS WORK IN ACCORDANCE WITH REGULATIONS OF AN AIRWORTHINESS AUTHORITY DIFFERENT THAN THE AIRWORTHINESS AUTHORITY SPECIFIED IN BLOCK 1, IT IS ESSENTIAL THAT THE USER/INSTALLER ENSURES THAT HIS/HER AIRWORTHINESS AUTHORITY ACCEPTS ITEMS FROM THE AIRWORTHINESS AUTHORITY SPECIFIED IN BLOCK 1.

STATEMENTS IN BLOCKS 13A AND 14A DO NOT CONSTITUTE INSTALLATION CERTIFICATION. IN ALL CASES AIRCRAFT MAINTENANCE RECORDS MUST CONTAIN AN INSTALLATION CERTIFICATION ISSUED IN ACCORDANCE WITH THE NATIONAL REGULATIONS BY THE USER/INSTALLER BEFORE THE AIRCRAFT MAY BE FLOWN.”

1. Competent Authority / Country: Maldives Civil Aviation Authority		2. AUTHORISED RELEASE CERTIFICATE CAA FORM 1				3. Form Tracking Number
4. Organisation Name and Address:						
6. Item	7. Description	8. Part No.	9. Qty.	10. Serial No.	11. Status/Work	
12. Remarks						
13a. Certifies that the items identified above were manufactured in conformity to:		14a. <input type="checkbox"/> MCAR-145.A.50 Release to Service <input type="checkbox"/> Other regulation specified in block 12				
<input type="checkbox"/> approved design data and are in a condition for safe operation <input type="checkbox"/> non-approved design data specified in block 12		Certifies that unless otherwise specified in block 12, the work identified in block 11 and described in block 12, was accomplished in accordance with MCAR-145 and in respect to that work the items are considered ready for release to service.				
13b. Authorised Signature	13c. Approval/Authorisation Number	14b. Authorised Signature			14c. Certificate/Approval Ref. No.	
13d. Name	13e. Date (dd mmm yyyy)	14d. Name			14e. Date (dd mmm yyyy)	
USER/INSTALLER RESPONSIBILITIES This certificate does not automatically constitute authority to install the item(s). Where the user/installer performs work in accordance with regulations of an airworthiness authority different than the airworthiness authority specified in block 1, it is essential that the user/installer ensures that his/her airworthiness authority accepts items from the airworthiness authority specified in block 1. Statements in blocks 13a and 14a do not constitute installation certification. In all cases aircraft maintenance records must contain an installation certification issued in accordance with the national regulations by the user/installer before the aircraft may be flown.						

CAA Form 1 — MF/CAO/145 Issue 3, 15 November 2021

AMC to Appendix II to MCAR-M - Use of the CAA Form 1 for maintenance

1. The following formats of an issued CAA Form 1 or equivalent certificate are acceptable:
 - A paper certificate bearing a signature (both originals and copies are accepted);
 - A paper certificate generated from an electronic system (printed from electronically stored data) when complying with the following subparagraph 2;
 - An electronic CAA Form 1 or equivalent when complying with the following subparagraph 2.
2. Electronic signature and electronic exchange of the CAA Form 1
 - a) Submission to the CAA

Any organisation intending to implement an electronic signature procedure to issue CAA Form 1 and/or to exchange electronically such data contained on the CAA Form 1, should document it and submit it to the CAA as part of the documents attached to its exposition.
 - b) Characteristics of the electronic system generating the CAA Form 1

The electronic system should:

 - guarantee secure access for each certifying staff;
 - ensure integrity and accuracy of the data certified by the signature on the form and be able to show evidence of the authenticity of the CAA Form 1 (recording and record keeping) with suitable security, safeguards and backups;
 - be active only at the location where the part is being released with a CAA Form 1;
 - not permit to sign a blank form;
 - provide a high degree of assurance that the data has not been modified after signature (if modification is necessary after issuance, i.e., re-certification of a part, a new form with a new number and reference to the initial issuance should be made).
 - provide for a 'personal' electronic signature, identifying the signatory. The signature should be generated only in presence of the signatory.

An electronic signature means data in electronic form which is attached to or logically associated with other electronic data and which serves as a method of authentication and should meet the following criteria:

- it is uniquely linked to the signatory;
- it is capable of identifying the signatory;
- it is created using means that the signatory can maintain under his sole control.

This electronic signature should be an electronically generated value based on a cryptographic algorithm and appended to data in a way to enable the verification of the data's source and integrity.

Organisation(s) are reminded that additional national requirements may need to be satisfied when operating electronic systems. 'Directive 1999/93/EC of the European Parliament and of the Council of 13 December 1999 on a Community framework for electronic signatures', as last amended, may constitute a reference.

The electronic system should be based on a policy and management structure (confidentiality, integrity and availability), such as:

- Administrators, signatories;
- Scope of authorisation, rights;
- Password and secure access, authentication, protections, confidentiality;
- Track changes;
- Minimum blocks to be completed, completeness of information;
- Archives;
- etc.

The electronic system generating the CAA Form 1 may contain additional data such as;

- Manufacturer code;
- Customer identification code;
- Workshop report;
- Inspection results;
- etc.

c) Characteristics of the CAA Form 1 generated from the electronic system

To facilitate understanding and acceptance of the CAA Form 1 released with an electronic signature, the following statement should be in Block 14b: 'Electronic Signature on File'.

In addition to this statement, it is accepted to print or display a signature in any form, such as a representation of the hand-written signature of the person signing (i.e. scanned signature) or a representation of their name.

When printing the electronic form, the CAA Form 1 should meet the general format as specified in Appendix II to MCAR-M. A watermark-type 'PRINTED FROM ELECTRONIC FILE' should be printed on the document.

When the electronic file contains a hyperlink to data required to determine the airworthiness of the item(s), the data associated to the hyperlink, when printed, should be in a legible format and be identified as a reference from the CAA Form 1.

Additional information not required by the CAA Form 1 completion instructions may be added

to the printed copies of CAA Form 1, as long as the additional data do not prevent a person from filling out, issuing, printing, or reading any portion of the CAA Form 1. This additional data should be provided only in block 12 unless it is necessary to include it in another block to clarify the content of that block.

d) Electronic exchange of the electronic CAA Form 1

The electronic exchange of the electronic CAA Form 1 should be accomplished on a voluntary basis. Both parties (issuer and receiver) should agree on electronic transfer of the CAA Form 1.

For that purpose, the exchange needs to include:

- all data of the CAA Form 1, including referenced data required by the CAA Form 1 completion instructions;
- all data required for authentication of the CAA Form 1.
- In addition, the exchange may include:
 - data necessary for the electronic format;
 - additional data not required by the CAA Form 1 completion instructions, such as manufacturer code, customer identification code.
- The system used for the exchange of the electronic CAA Form 1 should provide:
 - A high level of digital security; the data should be protected, not altered or not corrupted;
 - Traceability of data back to its source.

Trading partners wishing to exchange CAA Form 1 electronically should do so in accordance with the means of compliance stated in this document. It is recommended that they use an established, common, industry method such as Air Transport Association (ATA) Spec 2000 Chapter 16.

The organisation(s) are reminded that additional national requirements may need to be satisfied when operating the electronic exchange of the electronic CAA Form 1.

The receiver should be capable of regenerating the CAA Form 1 from the received data without alteration; if not, the system should revert back to the paper system.

When the receiver needs to print the electronic form, refer to subparagraph c) here above.

GM to Appendix II to MCAR-M - Use of the CAA Form 1 for maintenance
CAA Form 1 Block 12 'Remarks'

The CAA Form 1 identifies the airworthiness status of an aircraft component in relation to the work being certified. Block 12 'Remarks' of the CAA Form 1 in some cases contains vital airworthiness-related information (see also Appendix II to MCAR-M) which may need appropriate and necessary actions.

Examples of data to be entered in this block as appropriate:

- Maintenance documentation used, including the revision status, for all work performed and not limited to the entry made in block 11. A statement such as 'in accordance with the CMM' is not acceptable.
- NDT methods with appropriate documentation used when relevant.
- Compliance with airworthiness directives or service bulletins.
- Replacement parts installed.
- Life-limited parts status.
- Shelf life limitations.
- Deviations from the customer work order.
- Release statements to satisfy a foreign Civil Aviation Authority maintenance requirement.
- Information needed to support shipment with shortages or re-assembly after delivery.
- References to aid traceability, such as batch numbers."

Appendix III Airworthiness Review Certificate - CAA Form 15

Form 15a

بِسْمِ اللَّهِ الرَّحْمَنِ الرَّحِيمِ



MALDIVES CIVIL AVIATION AUTHORITY
REPUBLIC OF MALDIVES

ARC Reference
MV-MI-XXXX Issue X

AIRWORTHINESS REVIEW CERTIFICATE

Pursuant to Civil Aviation Regulations for the time being in force, the Civil Aviation Authority hereby certifies that the following aircraft:

Aircraft manufacturer:	
Manufacturer's designation:	
Aircraft registration:	
Aircraft Serial Number:	

is considered to be airworthy at the time of the review.

Date of Issue:		Date of expiry:	
Airframe Flight Hours (FH) at date of review (**):			
Signed:		Authorisation No:	

1st Extension: The aircraft has remained in a controlled environment in accordance with M.A. 901 of MCAR-M for the last year. The aircraft is considered to be airworthy at the time of the issue.

Date of Issue:		Date of expiry:	
Airframe Flight Hours (FH) at date of issue (**):			
Signed:		Authorisation No:	
Company name:		Approval reference:	

2nd Extension: The aircraft has remained in a controlled environment in accordance with M.A. 901 of MCAR-M for the last year. The aircraft is considered to be airworthy at the time of the issue.

Date of Issue:		Date of expiry:	
Airframe Flight Hours (FH) at date of issue (**):			
Signed:		Authorisation No:	
Company name:		Approval reference:	

CAA Form 15a (Issue 6, 15 Jan 2025)

(**) Except for balloons and airships

ARC Form 15b



**MALDIVES CIVIL AVIATION AUTHORITY
 REPUBLIC OF MALDIVES**

**ARC Reference
 MV-MI-XXXX Issue X**

AIRWORTHINESS REVIEW CERTIFICATE

Pursuant to Civil Aviation Regulations for the time being in force, the following organisation, approved in accordance with Section A of MCAR-CAMO or Section A of Subpart G of MCAR-M or Section A of MCAR-CAO,

[NAME OF THE ORGANISATION APPROVED AND ADDRESS]

[APPROVAL REFERENCE]

hereby certifies that it has performed an airworthiness review in accordance with point M.A.901 of MCAR-M on the following aircraft:

Aircraft manufacturer:	
Manufacturer's designation:	
Aircraft registration:	
Aircraft Serial Number:	

and this aircraft is considered to be airworthy at the time of the review.

Date of Issue:		Date of expiry:	
Airframe Flight Hours (FH) at date of review (**):			
Signed:		Authorisation No:	

1st Extension: The aircraft has remained in a controlled environment in accordance with M.A.901 of MCAR-M for the last year. The aircraft is considered to be airworthy of the time of the issue.

Date of Issue:		Date of expiry:	
Airframe Flight Hours (FH) at date of issue (**):			
Signed:		Authorisation No:	
Company name:		Approval reference:	

2nd Extension: The aircraft has remained in a controlled environment in accordance with M.A.901 of MCAR-M for the last year. The aircraft is considered to be airworthy of the time of the issue.

Date of Issue:		Date of expiry:	
Airframe Flight Hours (FH) at date of issue (**):			
Signed:		Authorisation No:	
Company name:		Approval reference:	

CAA Form 15b (Issue 6, 15 Jan 2025)

(**) Except for airships

Appendix IV - Class and Rating System for the Terms of Approval of Maintenance Organisations referred to in MCAR-M Subpart F

1. Except as stated otherwise for the smallest organisations in point 11, the table in point 12 provides for the standard system for the approval of a maintenance organisation referred to in Subpart F of MCAR-M. An organisation must be granted an approval that ranges from a single class and rating with limitations to all classes and ratings with limitations.
2. In addition to the table referred to in point 12, the approved maintenance organisation is required to indicate its scope of work in its maintenance organisation manual..
3. Within the approval class(es) and rating(s) granted by the CAA, the scope of work specified in the maintenance organisation exposition defines the exact limits of approval. It is therefore essential that the approval class(es) and rating(s) and the organisations scope of work are matching.
4. A category A class rating means that the approved maintenance organisation may carry out maintenance on the aircraft and any component (including engines and/or Auxiliary Power Units (APUs), in accordance with aircraft maintenance data or, if agreed by the CAA, in accordance with component maintenance data, only whilst such components are fitted to the aircraft. Nevertheless, such A-rated approved maintenance organisation may temporarily remove a component for maintenance, in order to improve access to that component, except when such removal generates the need for additional maintenance not eligible for the provisions of this point. This will be subject to a control procedure in the maintenance organisation exposition to be approved by the CAA. The limitation section will specify the scope of such maintenance thereby indicating the extent of approval.
5. A category B class rating means that the approved maintenance organisation may carry out maintenance on the uninstalled engine and/or APU and engine and/or APU components, in accordance with engine and/or APU maintenance data or, if agreed by the CAA, in accordance with component maintenance data, only whilst such components are fitted to the engine and/or APU. Nevertheless, such B-rated approved maintenance organisation may temporarily remove a component for maintenance, in order to improve access to that component, except when such removal generates the need for additional maintenance not eligible for the provisions of this point. The limitation section will specify the scope of such maintenance thereby indicating the extent of approval. A maintenance organisation approved with a category B class rating may also carry out maintenance on an installed engine during 'base' and 'line' maintenance subject to a control procedure in the maintenance organisation exposition to be approved by the CAA. The maintenance organisation exposition scope of work shall reflect such activity where permitted by the CAA.
6. A category C class rating means that the approved maintenance organisation may carry out maintenance on uninstalled components (excluding engines and APUs) intended for fitment to the aircraft or engine/APU. The limitation section will specify the scope of such maintenance thereby indicating the extent of approval. A maintenance organisation approved with a category C class rating may also carry out maintenance on an installed component during base and line maintenance or at an engine/APU maintenance facility subject to a control procedure in the maintenance organisation exposition to be approved by the CAA. The maintenance organisation exposition scope of work shall reflect such activity where permitted by the CAA.
7. A category D class rating is a self contained class rating not necessarily related to a specific aircraft, engine or other component. The D1 – Non Destructive Testing (NDT) rating is only necessary for an approved maintenance organisation that carries out NDT as a particular task for another organisation. A maintenance organisation approved with a class rating in A or B or C category may

carry out NDT on products it is maintaining subject to the maintenance organisation exposition containing NDT procedures, without the need for a D1 class rating.

8. The limitation section is intended to give the CAA the flexibility to customise the approval to any particular organisation. Ratings shall be mentioned on the approval only when appropriately limited. The table referred to in point 12 specifies the types of limitation possible. Whilst maintenance is listed last in each class rating it is acceptable to stress the maintenance task rather than the aircraft or engine type or manufacturer, if this is more appropriate to the organisation (an example could be avionics systems installations and related maintenance). Such mention in the limitation section indicates that the maintenance organisation is approved to carry out maintenance up to and including this particular type/task.
9. When reference is made to series, type and group in the limitation section of class A and B, series means a specific type series such as Cessna 150 or Cessna 172 or Beech 55 series or continental O-200 series etc; type means a specific type or model such as Cessna 172RG type; any number of series or types may be quoted; group means for example Cessna single piston engine aircraft or Lycoming non-supercharged piston engines etc.
10. When a lengthy capability list is used which could be subject to frequent amendments, then such amendments may be performed in accordance with the indirect approval procedure referred to in points M.A.604(c) and M.B.606(c).
11. A maintenance organisation which employs only one person to both plan and carry out all maintenance can only hold a limited scope of approval rating. The maximum permissible limits are:

CLASS	RATING	LIMITATION
CLASS AIRCRAFT	RATING A2 AEROPLANES 5700 KG AND BELOW	PISTON ENGINE 5700 KG AND BELOW
CLASS AIRCRAFT	RATING A3 HELICOPTERS	SINGLE PISTON ENGINE 3175 KG AND BELOW
CLASS AIRCRAFT	RATING A4 AIRCRAFT OTHER THAN A1, A2 AND A3	NO LIMITATION
CLASS ENGINES	RATING B2 PISTON	LESS THAN 450 HP
CLASS COMPONENTS OTHER THAN COMPLETE ENGINES OR APU'S.	C1 TO C22	AS PER CAPABILITY LIST
CLASS SPECIALISED	D1 NDT	NDT METHOD(S) TO BE SPECIFIED.

It should be noted that such an organisation may be further limited by the CAA in the terms of approval depending on the capability of the particular organisation.

12. Table

CLASS	RATING	LIMITATION	BASE	LINE
AIRCRAFT	A2 Aeroplanes 5700 kg and below	[Shall state aeroplane manufacturer or group or series or type and/or the maintenance task(s)] <i>Example: DHC-6 Twin Otter Series</i> State whether the issue of airworthiness review certificates is authorised	[YES/NO] *	[YES/NO] *
	A3 Helicopters	[Shall state helicopter manufacturer or group or series or type and/or the maintenance task(s)] <i>Example: Robinson R44</i>	[YES/NO] *	[YES/NO] *
	A4 Aircraft other than A1, A2 and A3	[Shall state aircraft category (sailplane, balloon, airship, etc), manufacturer or group or series or type and/or the maintenance task(s).] State whether the issue of airworthiness review certificates is authorised	[YES/NO] *	[YES/NO] *
ENGINES	B1 Turbine	[Shall state engine series or type and/or the maintenance task(s)] Example: PT6A Series		
	B2 Piston	[Shall state engine manufacturer or group or series or type and/or the maintenance task(s)]		
	B3 APU	[Shall state engine manufacturer or series or type and/or the maintenance task(s)]		
COMPONENTS OTHER THAN COMPLETE ENGINES OR APUs	C1 Air Cond & Press	[Shall state aircraft type or aircraft manufacturer or component manufacturer or the particular component and/or cross refer to a capability list in the exposition and/or the maintenance task(s).] Example: PT6A Fuel Control		
	C2 Auto Flight			
	C3 Comms and Nav			
	C4 Doors - Hatches			
	C5 Electrical Power & Lights			
	C6 Equipment			
	C7 Engine - APU			
	C8 Flight Controls			
	C9 Fuel			
	C10 Helicopter - Rotors			
	C11 Helicopter - Trans			
	C12 Hydraulic Power			
	C13 Indicating - recording system			
	C14 Landing Gear			
	C15 Oxygen			
	C16 Propellers			
	C17 Pneumatic & Vacuum			
	C18 Protection ice/ rain/fire			

	C19 Windows	
	C20 Structural	
	C21 Water ballast	
	C22 Propulsion Augmentation	
SPECIALISED SERVICES	D1 Non Destructive Testing	[Shall state particular NDT method(s)]

(*) Delete as appropriate

Appendix V - Maintenance Organisation Certificate referred to in MCAR-M Subpart F - CAA Form 3-MF

بِسْمِ اللّٰهِ الرَّحْمٰنِ الرَّحِیْمِ



**MALDIVES CIVIL AVIATION AUTHORITY
REPUBLIC OF MALDIVES**

**Reference:
MV.MF.XXXX**

MAINTENANCE ORGANISATION CERTIFICATE

Pursuant to Civil Aviation Regulations for the time being in force and subject to the conditions specified below, the Civil Aviation Authority hereby certifies:

[COMPANY NAME]
[COMPANY ADDRESS]

as a maintenance organisation in compliance with MCAR-M Section A Subpart F, approved to maintain the products, parts and appliances listed in the attached terms of approval and issue related certificates of release to service using the above references and, when stipulated, airworthiness review certificates after an airworthiness review as specified in point ML.A.903 of MCAR-ML for those aircraft listed in the attached terms of approval.

CONDITIONS

1. This certificate is limited to what is specified in the scope of work section of the approved maintenance organisation manual as referred to in Section A, Subpart F of MCAR-M; and
2. This certificate requires compliance with the procedures specified in the approved maintenance organisation manual; and
3. This approval is valid whilst the approved maintenance organisation remains in compliance with MCAR-M and MCAR-ML.
4. Subject to compliance with the foregoing conditions, this approval shall remain valid until 01 July 2023 for an unlimited duration unless the certificate has been surrendered, superseded, suspended or revoked before that date.

Revision Number:
Date of this Revision:
Date of Original Issue:

Signed:
For the Civil Aviation Authority

MAINTENANCE ORGANISATION APPROVAL SCHEDULE

Reference: **MV.MF.XXXX**

Organisation: **[COMPANY NAME]**
 [COMPANY ADDRESS]

CLASS	RATING	LIMITATION
AIRCRAFT (**)	(***)	(****)
	(***)	(****)
ENGINES (**)	(***)	(***)
	(***)	(***)
COMPONENTS OTHER THAN COMPLETE ENGINES OR APUs (**)	(***)	(***)
	(***)	(***)
	(***)	(***)
	(***)	(***)
	(***)	(***)
	(***)	(***)
SPECIALISED SERVICES (**)	(***)	(***)
	(***)	(***)

These terms of approval are limited to the products, parts and appliances and to the activities specified in the scope of work section of the approved maintenance organisation manual.

Maintenance Organisation Manual Reference:

Revision Number:
Date of this Revision:
Date of Original Issue:

Signed:
For the Civil Aviation Authority

** Delete as appropriate if the organisation is not approved

*** Complete with the appropriate rating and limitation

**** Complete with the appropriate limitation and state whether the issue of airworthiness review certificates is authorised or not (only possible for ELA1 aircraft not involved in commercial operations when the organisation performs the airworthiness review together with the annual inspection contained in the AMP)

AMC to Appendix V to MCAR-M - Maintenance Organisation Approval referred to in MCAR-M Subpart F

The following fields on page 2 “Maintenance Organisation Approval Schedule” of the maintenance organisation approval certificate should be completed as follows:

- Date of original issue: It refers to the date of the original issue of the maintenance organisation manual
- Date of last revision approved: It refers to the date of the last revision of the maintenance organisation manual affecting the content of the certificate. Changes to the maintenance organisation manual which do not affect the content of the certificate do not require the reissuance of the certificate.
- Revision No: It refers to the revision No of the last revision of the maintenance organisation manual affecting the content of the certificate. Changes to the maintenance organisation manual which do not affect the content of the certificate do not require the reissuance of the certificate.

Appendix VI - Continuing Airworthiness Management Organisation Certificate referred to in MCAR-M Subpart G – CAA Form 14-MG

بِسْمِ اللَّهِ الرَّحْمَنِ الرَّحِيمِ



**MALDIVES CIVIL AVIATION AUTHORITY
REPUBLIC OF MALDIVES**

**Reference:
MV.MG.XXXX (REF. AOC. XXXX)**

**CONTINUING AIRWORTHINESS MANAGEMENT ORGANISATION
CERTIFICATE**

Pursuant to Civil Aviation Regulations for the time being in force and subject to the conditions specified below, the Civil Aviation Authority hereby certifies:

[COMPANY NAME]
[COMPANY ADDRESS]

as a continuing airworthiness management organisation in compliance with Section A, Subpart G of MCAR-M, approved to manage the continuing airworthiness of the aircraft listed in the attached terms of approval and, when stipulated, to issue recommendations and airworthiness review certificates after an airworthiness review as specified in point M.A.901 of MCAR-M or ML.A.901 of MCAR-ML, and, when stipulated, to issue permits to fly as specified in point M.A.711(c) of MCAR-M.

CONDITIONS

1. This certificate is limited to that specified in the scope of work section of the approved continuing airworthiness management exposition as referred to in Section A, Subpart G of MCAR-M.
2. This certificate requires compliance with the procedures specified in the continuing airworthiness management exposition approved in accordance with Subpart G of MCAR-M.
3. This certificate is valid whilst the approved continuing airworthiness management organisation remains in compliance with MCAR-M and, if applicable, MCAR-ML.
4. Where the continuing airworthiness management organisation contracts under its Quality System the service of an organisation or several organisations, this certificate remains valid subject to such organisation(s) fulfilling applicable contractual obligations.
5. Subject to compliance with the conditions 1 to 4 above, this certificate shall remain valid until 01 July 2023, unless the certificate has previously been surrendered, superseded, suspended or revoked.

If this form is also used for licenced air carriers, the Air Operator Certificate (AOC) number shall be added to the reference, in addition to the standard number, and the condition 5 shall be replaced by the following extra conditions 6, 7 and 8:

6. This certificate does not constitute an authorisation to operate the types of aircraft referred in condition 1. The authorisation to operate the aircraft is the AOC.
7. Termination, suspension or revocation of the AOC automatically invalidates this certificate in relation to the aircraft registrations specified in the AOC, unless otherwise explicitly stated by the CAA.
- 8.. Subject to compliance with the conditions 1 to 4, 6 and 7, this certificate shall remain valid until 01 July 2023, for an unlimited duration unless the certificate has previously been surrendered, superseded, suspended or revoked.

Revision No:
Date of this revision:
Date of original issue:

Signed:
For the Civil Aviation Authority

**CONTINUING AIRWORTHINESS MANAGEMENT ORGANISATION
 TERMS OF APPROVAL**

Reference: **MV.MG.XXXX (Ref. AOC.MV.XXXX)**

Organisation: **[COMPANY NAME]**
 [COMPANY ADDRESS]

AIRCRAFT TYPE/SERIES/GROUP	AIRWORTHINESS REVIEW AUTHORISED	PERMITS TO FLY AUTHORISED	ORGANISATION(S) WORKING UNDER QUALITY SYSTEM
	[YES / NO] (***)	[YES / NO] (***)	
	[YES / NO] (***)	[YES / NO] (***)	
	[YES / NO] (***)	[YES / NO] (***)	
	[YES / NO] (***)	[YES / NO] (***)	

These terms of approval are limited to that specified in the scope of work contained in the approved Continuing Airworthiness Management Exposition section -----

Continuing Airworthiness Management Exposition reference

Revision No:
Date of this revision:
Date of original issue:

Signed:
For the Civil Aviation Authority

AMC to Appendix VI to MCAR-M - Continuing Airworthiness Management Organisation Approval referred to in MCAR-M Subpart G

The following fields on page 2 “Continuing Airworthiness Management Organisation Approval Schedule” of the continuing airworthiness management organisation approval certificate should be completed as follows:

- Date of original issue: It refers to the date of the original issue of the continuing airworthiness management exposition
- Date of last revision: It refers to the date of the last revision of the continuing airworthiness management exposition affecting the content of the certificate. Changes to the continuing airworthiness management exposition which do not affect the content of the certificate do not require the reissuance of the certificate.
- Revision No: It refers to the revision No of the last revision of the continuing airworthiness management exposition affecting the content of the certificate. Changes to the continuing airworthiness management exposition which do not affect the content of the certificate do not require the reissuance of the certificate.

Appendix VII Complex Maintenance Tasks

The following constitutes the complex maintenance tasks referred to in M.A.801(b):

1. The modification, repair or replacement by riveting, bonding, laminating, or welding of any of the following airframe parts:
 - (a) a box beam;
 - (b) a wing stringer or chord member;
 - (c) a spar;
 - (d) a spar flange;
 - (e) a member of a truss-type beam;
 - (f) the web of a beam;
 - (g) a keel or chine member of a flying boat hull or a float;
 - (h) a corrugated sheet compression member in a wing or tail surface;
 - (i) a wing main rib;
 - (j) a wing or tail surface brace strut;
 - (k) an engine mount;
 - (l) a fuselage longeron or frame;
 - (m) a member of a side truss, horizontal truss or bulkhead;
 - (n) a seat support brace or bracket;
 - (o) a seat rail replacement;
 - (p) a landing gear strut or brace strut;
 - (q) an axle;
 - (r) a wheel; and
 - (s) a ski or ski pedestal, excluding the replacement of a low-friction coating.

2. The modification or repair of any of the following parts:
 - (a) aircraft skin, or the skin of an aircraft float, if the work requires the use of a support, jig or fixture;
 - (b) aircraft skin that is subject to pressurization loads, if the damage to the skin measures more than 15 cm (6 inches) in any direction;

- (c) a load-bearing part of a control system, including a control column, pedal, shaft, quadrant, bell crank, torque tube, control horn and forged or cast bracket, but excluding
 - (i) the swaging of a repair splice or cable fitting, and
 - (ii) the replacement of a push-pull tube end fitting that is attached by riveting; and
 - (d) any other structure, not listed in (1), that a manufacturer has identified as primary structure in its maintenance manual, structural repair manual or instructions for continuing airworthiness.
3. The performance of the following maintenance on a piston engine:
- (a) dismantling and subsequent reassembling of a piston engine other than
 - (i) to obtain access to the piston/cylinder assemblies; or
 - (ii) to remove the rear accessory cover to inspect and/or replace oil pump assemblies, where such work does not involve the removal and re-fitment of internal gears;
 - (b) dismantling and subsequent reassembling of reduction gears;
 - (c) welding and brazing of joints, other than minor weld repairs to exhaust units carried out by a suitably approved or authorised welder but excluding component replacement;
 - (d) the disturbing of individual parts of units which are supplied as bench tested units, except for the replacement or adjustment of items normally replaceable or adjustable in service.
4. The balancing of a propeller, except:
- (a) for the certification of static balancing where required by the maintenance manual;
 - (b) dynamic balancing on installed propellers using electronic balancing equipment where permitted by the maintenance manual or other approved airworthiness data;
5. Any additional task that requires:
- (a) specialized tooling, equipment or facilities; or
 - (b) significant coordination procedures because of the extensive duration of the tasks and the involvement of several persons.

AMC to Appendix VII - "Complex Maintenance Tasks"

The sentence "suitably approved or authorised welder" contained in Appendix VII, paragraph 3(c), means that the qualification should meet an officially recognised standard or, otherwise, should be accepted by the CAA.

Appendix VIII - Limited Pilot-Owner Maintenance

In addition to the requirements laid down in this regulation, the following basic principles are to be complied with before any maintenance task is carried out under the terms of Pilot-owner maintenance:

(a) Competence and responsibility

1. The Pilot-owner is always responsible for any maintenance that he performs.
2. Before carrying out any Pilot-owner maintenance tasks, the Pilot-owner must satisfy himself that he is competent to do the task. It is the responsibility of Pilot-owners to familiarize themselves with the standard maintenance practices for their aircraft and with the aircraft maintenance programme. If the Pilot-owner is not competent for the task to be carried out, the task cannot be released by the Pilot-owner.
3. The Pilot-owner (or his contracted CAMO or CAO) is responsible for identifying the Pilot-owner tasks according to these basic principles in the maintenance programme and for ensuring that the document is updated in a timely manner.
4. The approval of the maintenance programme has to be carried out in accordance with point M.A.302.

(b) Tasks

The Pilot-owner may carry out simple visual inspections or operations to check for general condition and obvious damage and normal operation of the airframe, engines, systems and components.

Maintenance tasks shall not be carried out by the Pilot-owner when the task:

1. is a critical maintenance task;
2. requires the removal of major components or major assembly and/or;
3. is carried out in compliance with an Airworthiness Directive or an Airworthiness Limitation Item, unless specifically allowed in the AD or the ALI and/or;
4. requires the use of special tools, calibrated tools (except torque wrench and crimping tool) and/or;
5. requires the use of test equipment or special testing (e.g. NDT, system tests or operational checks for avionic equipment) and/or;
6. is composed of any unscheduled special inspections (e.g. heavy landing check) and/or;
7. is effecting systems essential for the IFR operations and/or;
8. is listed in Appendix VII to this Regulation or is a component maintenance task in accordance with points M.A.502(a), (b), (c) or (d) and/or;

The criteria 1 to 8 cannot be overridden by less restrictive instructions issued in accordance with "M.A.302(d) Maintenance Programme".

Any task described in the aircraft flight manual as preparing the aircraft for flight (Example: assembling the glider wings or pre-flight), is considered to be a pilot task and is not considered a Pilot-owner maintenance task and therefore does not require a Certificate of Release to Service.

(c) Performance of the maintenance Pilot-owner tasks and records

The maintenance data as specified in point M.A.401 must be always available during the conduct of Pilot-owner maintenance and must be complied with. Details of the data referred to in the conduct of Pilot-owner maintenance must be included in the Certificate of Release to Service in accordance with point M.A.803(d).

The Pilot-owner must inform the approved continuing airworthiness management organisation responsible for the continuing airworthiness of the aircraft (if applicable) not later than 30 days after completion of the Pilot-owner maintenance task in accordance with point M.A.305(a).

AMC to Appendix VIII - "Limited Pilot Owner Maintenance"

1. The lists here below specify items that can be expected to be completed by an owner who holds a current and valid pilot licence for the aircraft type involved and who meets the competence and responsibility requirements of Appendix VIII to MCAR-M.
2. The list of tasks may not address in a detailed manner the specific needs of the various aircraft categories. In addition, the development of technology and the nature of the operations undertaken by these categories of aircraft cannot be always adequately considered.
3. Therefore, the following lists are considered to be the representative scope of limited Pilot-owner maintenance referred to in M.A.803 and Appendix VIII:
 - Part A applies to aeroplanes;
 - Part B applies to rotorcraft;
 - Part C applies to sailplanes and powered sailplanes;
 - Part D applies to balloons and airships.
4. Inspection tasks/checks of any periodicity included in an approved maintenance programme can be carried out providing that the specified tasks are included in the generic lists of Parts A to D of this AMC and remains compliant with MCAR-M Appendix VIII basic principles.

The content of periodic inspections/checks as well as their periodicity is not regulated or standardised in an aviation specification. It is the decision of the manufacturer/Type Certificate Holder (TCH) to recommend a schedule for each specific type of inspection/check.

For an inspection/check with the same periodicity for different TCHs, the content may differ, and in some cases may be critically safety-related and may need the use of special tools or knowledge and thus would not qualify for Pilot-owner maintenance. Therefore, the maintenance carried out by the Pilot-owner cannot be generalised to specific inspections such as 50 Hrs, 100 Hrs or 6 Month periodicity.

The Inspections to be carried out are limited to those areas and tasks listed in this AMC to Appendix VIII; this allows flexibility in the development of the maintenance programme and does not limit the inspection to certain specific periodic inspections. A 50 Hrs/6 Month periodic inspection for a fixed wing aeroplane as well as the one-year inspection on a glider may normally be eligible for Pilot-owner maintenance.

TABLES

Note: Tasks in Part A or Part B shown with ** exclude IFR operations following Pilot-owner maintenance. For these aircraft to operate under IFR operations, these tasks should be released by an appropriate licensed engineer.

Part A/ PILOT-OWNER MAINTENANCE TASKS for POWERED AIRCRAFT (AEROPLANES)

ATA	Area	Task	Aeroplanes ≤2730 kg
09	Towing	Tow release unit and tow cable retraction mechanism – Cleaning, lubrication and tow cable replacement (including weak links).	Yes
		Mirror –Installation and replacement of mirrors.	Yes
11	Placards	Placards, Markings – Installation and renewal of placards and markings required by AFM and AMM.	Yes
12	Servicing	Lubrication – Those items not requiring a disassembly other than of non-structural items such as cover plates, cowlings and fairings.	Yes
20	Standard Practices	Safety Wiring – Replacement of defective safety wiring or cotter keys, excluding those in engine controls, transmission controls and flight control systems.	Yes
		Simple Non-Structural Standard Fasteners – Replacement and adjustment, excluding the replacement of receptacles and anchor nuts requiring riveting.	Yes
21	Air Conditioning	Replacement of flexible hoses and ducts.	Yes
23	Communication.	Communication devices – Remove and replace self contained, instrument panel mount communication devices with quick disconnect connectors, excluding IFR operations.	Yes**
24	Electrical power	Batteries – Replacement and servicing, excluding servicing of Ni-Cd batteries and IFR operations.	Yes**
		Wiring – Repairing broken circuits in non critical equipment, excluding ignition system, primary generating system and required communication, navigation system and primary flight instruments.	Yes
		Bonding – Replacement of broken bonding cable.	Yes
		Fuses – Replacement with the correct rating.	Yes
25	Equipment	Safety Belts – Replacement of safety belts and harnesses excluding belts fitted with airbag systems.	Yes
		Seats – Replacement of seats or seat parts not involving disassembly of any primary structure or control system.	Yes
		Non-essential instruments and/or equipment – Replacement of self contained, instrument panel mount equipment with quick disconnect connectors.	Yes
		Oxygen System – Replacement of portable oxygen bottles and systems in approved mountings, excluding permanently installed bottles and systems.	Yes
		ELT – Removal/Reinstallation.	Yes

ATA	Area	Task	Aeroplanes ≤2730 kg
27	Flight controls	Removal or reinstallation of co-pilot control column and rudder pedals where provision for quick disconnect is made by design.	Yes
28	Fuel System	Fuel Filter elements – Cleaning and/or replacement.	Yes
30	Ice and Rain Protection	Windscreen Wiper – Replacement of wiper blade.	Yes
31	Instruments	Instrument Panel – Removal and reinstallation provided this it is a design feature with quick disconnect connectors, excluding IFR operations.	Yes**
		Pitot Static System – Simple sense and leak check, excluding IFR operations.	Yes**
		Drainage – Drainage of water drainage traps or filters within the Pitot Static system excluding IFR operations.	Yes**
		Instruments – Check for legibility of markings and those readings are consistent with ambient conditions.	Yes
32	Landing Gear	Wheels – Removal, replacement and servicing, including replacement of wheel bearings and lubrication.	Yes
		Servicing – Replenishment of hydraulic fluid	Yes
		Shock Absorber – Replacement of elastic cords or rubber dampers.	Yes
		Shock Struts – Replenishment of oil or air.	Yes
		Skis – Changing between wheel and ski landing gear.	Yes
		Landing skids – Replacement of landing skids and skid shoes.	Yes
		Wheel fairings (spats) – Removal and reinstallation.	Yes
		Mechanical brakes – Adjustment of simple cable operated systems.	Yes
		Brake – Replacement of worn brake pads.	Yes
33	Lights	Lights – Replacements of internal and external bulbs, filaments, reflectors and lenses.	Yes
34	Navigation	Software – Updating self contained, instrument panel mount navigational software databases, excluding automatic flight control systems and transponders.	Yes
		Navigation devices – Removal and replacement of self contained, instrument panel mount navigation devices with quick disconnect connectors, excluding automatic flight control systems, transponders, primary flight control system and IFR operations.	Yes**
		Self contained data logger – Installation, data restoration.	Yes
51	Structure	Fabric patches – Simple patches extending over not more than one rib and not requiring rib stitching or removal of structural parts or control surfaces.	Yes
		Protective Coating – Applying preservative material or coatings where no disassembly of any primary structure or operating system is involved.	Yes

ATA	Area	Task	Aeroplanes ≤2730 kg
		Surface finish – Minor restoration where no disassembly of any primary structure or operating system is involved This includes application of signal coatings or thin foils as well as registration markings.	Yes
		Fairings – Simple repairs to non-structural fairings and cover plates which do not change the contour	Yes
52	Doors and Hatches	Doors – Removal and reinstallation	Yes
53	Fuselage	Upholstery, furnishing – Minor repairs which do not require disassembly of primary structure or operating systems, or interfere with control systems.	Yes
56	Windows	Side Windows – Replacement if it does not require riveting, bonding or any special process	Yes
61	Propeller	Spinner – Removal and reinstallation.	Yes
71	Powerplant installation	Cowling – Removal and reinstallation not requiring removal of propeller or disconnection of flight controls.	Yes
		Induction System – Inspection and replacement of induction air filter.	Yes
72	Engine	Chip detectors – Removal, checking and reinstallation provided the chip detector is a self- sealing type and not electrically indicated.	Yes
73	Engine fuel	Strainer or Filter elements – Cleaning and/or replacement.	Yes
		Fuel – Mixing of required oil into fuel.	Yes
74	Ignition	Spark Plugs – Removal, cleaning, adjustment and reinstallation.	Yes
75	Cooling	Coolant – Replenishment of coolant fluid.	Yes
77	Engine Indicating	Engine Indicating – Removal and replacement of self contained, instrument panel mount indicators that have quick-release connectors and do not employ direct reading connections.	Yes
79	Oil System	Strainer or filter elements – Cleaning and/or replacement.	Yes
		Oil – Changing or replenishment of engine oil and gearbox fluid.	Yes

Part B/ PILOT-OWNER MAINTENANCE TASKS for ROTORCRAFT

ATA	Area	Task	Single Engine Rotorcraft <=2730 kg
11	Placards	Placards, Markings – Installation and renewal of placards and markings required by AFM and AMM.	Yes
12	Servicing	Fuel, oil, hydraulic, de-iced and windshield liquid replenishment.	Yes
		Lubrication – Those items not requiring a disassembly other than of non-structural items such as cover plates, cowlings and fairings.	Yes
20	Standard Practices	Safety Wiring – Replacement of defective safety wiring or cotter keys, excluding those in engine controls, transmission controls and flight control systems.	Yes
		Simple non-structural standard fasteners – Replacement and adjustment, excluding latches and the replacement of receptacles and anchor nuts requiring riveting.	Yes
21	Air Conditioning	Replacement of flexible hoses and ducts.	Yes
23	Communication	Communication devices – Remove and replace self contained, instrument panel mount communication devices with quick disconnect connectors, excluding IFR operations.	Yes**
24	Electrical power	Batteries – Replacement and servicing, excluding servicing of Ni-Cd batteries and IFR operations.	Yes**
		Wiring – Repairing broken circuits in noncritical equipment, excluding ignition system, primary generating system and required communication, navigation system and primary flight instruments.	Yes
		Bonding – Replacement of broken bonding cable excluding bonding on rotating parts and flying controls.	Yes
		Fuses – Replacement with the correct rating.	Yes
25	Equipment	Safety Belts – Replacement of safety belts and harnesses excluding belts fitted with airbag systems.	Yes
		Seats – Replacement of seats or seat parts not involving disassembly of any primary structure or control system excluding flight crew seats.	Yes
		Removal/installation of emergency flotation gears with quick disconnect connectors.	Yes
		Non-essential instruments and/or equipment – Replacement of self contained, instrument panel mount equipment with quick disconnect connectors.	Yes
		ELT – Removal/Reinstallation.	Yes
30	Ice and rain protection	Windshield wiper replacement	Yes
31	Instruments	Instrument Panel– Removal and reinstallation provided this it is a design feature with quick disconnect connectors, excluding IFR operations.	Yes**

ATA	Area	Task	Single Engine Rotorcraft <=2730 kg
		Pitot Static System – Simple sense and leak check, excluding IFR operations.	Yes**
		Drainage – Drainage of water drainage traps or filters within the Pitot Static system excluding IFR operations.	Yes**
		Instruments – Check for legibility of markings and those readings are consistent with ambient conditions.	Yes
32	Landing Gears	Wheels – Removal, replacement and servicing, including replacement of wheel bearings and lubrication.	Yes
		Replacement of skid wear shoes.	Yes
		Fit and remove snow landing pads.	Yes
		Servicing – Replenishment of hydraulic fluid.	Yes
		Brake – Replacement of worn brake pads.	Yes
33	Lights	Lights – replacement of internal and external bulbs, filaments, reflectors and lenses.	Yes
34	Navigation	Software – Updating self contained, instrument panel mount navigational software databases, excluding automatic flight control systems and transponders.	Yes
		Navigation devices – Remove and replace self contained, instrument panel mount navigation devices with quick disconnect connectors, excluding automatic flight control systems, transponders, primary flight control system and IFR operations.	Yes**
		Self contained data logger – Installation, data restoration.	Yes
51	Structure	Protective Coating – Applying preservative material or coatings where no disassembly of any primary structure or operating system is involved.	Yes
		Surface finish – Minor restoration where no disassembly of any primary structure or operating system is involved, excluding intervention on main and tail rotors. This includes application of signal coatings or thin foils as well as Registration markings.	Yes
		Fairings – Simple repairs to non-structural fairings and cover plates which do not change the contour.	Yes
52	Doors	Doors – Removal and reinstallation.	Yes
53	Fuselage	Upholstery, furnishing – Minor repairs which do not require disassembly of primary structure or operating systems, or interfere with control systems.	Yes
56	Windows	Side Windows – Replacement if it does not require riveting, bonding or any special process.	Yes
62	Main rotor	Removal/installation of main rotor blades that are designed for removal where special tools are not required (tail rotor blades excluded) limited to	Yes

ATA	Area	Task	Single Engine Rotorcraft <=2730 kg
		installation of the same blades previously removed refitted in the original position.	
63 65	Transmission	Chip detectors – Remove, check and replace provided the chip detector is a self-sealing type and not electrically indicated.	Yes
67	Flight control	Removal or reinstallation of co-pilot cyclic and collective controls and yaw pedals where provision for quick disconnect is made by design.	Yes
71	Powerplant installation	Cowlings – Removal and re-fitment.	Yes
72	Engine	Chip detectors –removal, checking and reinstallation provided the chip detector is a self sealing type and not electrically indicated.	Yes
79	Oil System	Filter elements – Replacement, provided that the element is of the “spin on/off” type.	Yes
		Oil – Changing or replenishment of engine oil.	Yes

Part C/ PILOT-OWNER MAINTENANCE TASKS for SAILPLANES AND POWERED SAILPLANES

Abbreviations applicable to this Part:

- N/A not applicable for this category
- SP sailplane
- SSPS self-sustained powered sailplane
- SLPS/TM self-launching powered sailplane/touring motorglider

ATA	Area	Task	SP	SSPS	SLPS / TM
08	Weighing	Recalculation – Small changes of the Trim plan without needing a reweighing.	Yes	Yes	Yes
09	Towing	Tow release unit and tow cable retraction mechanism – Cleaning, lubrication and tow cable replacement (including weak links).	Yes	Yes	Yes
		Mirror – Installation and replacement of mirrors.	Yes	Yes	Yes
11	Placards	Placards, Markings – Installation and renewal of placards and markings required by AFM and AMM.	Yes	Yes	Yes
12	Servicing	Lubrication – Those items not requiring a disassembly other than of non-structural items such as cover plates, cowlings and fairings.	Yes	Yes	Yes
20	Standard. Practices	Safety Wiring – Replacement of defective safety wiring or cotter keys, excluding those in engine controls, transmission controls and flight control systems.	Yes	Yes	Yes
		Simple Non-Structural Standard Fasteners – Replacement and adjustment, excluding the replacement of receptacles and anchor nuts requiring riveting.	Yes	Yes	Yes
		Free play – Measurement of the free play in the control system and the wing to fuselage attachment including minor adjustments by simple means provided by the manufacturer.	Yes	Yes	Yes
21	Air Conditioning	Replacement of flexible hoses and ducts.	Yes	Yes	Yes
23	Communication	Communication devices – Remove and replace self contained, instrument panel mount communication devices with quick disconnect connectors.	Yes	Yes	Yes
24	Electrical power	Batteries and solar panels – Replacement and servicing.	Yes	Yes	Yes
		Wiring – Installation of simple wiring connections to the existing wiring for additional non-required equipment such as electric variometers, flight computers but excluding required communication, navigation systems and engine wiring.	Yes	Yes	Yes

ATA	Area	Task	SP	SSPS	SLPS / TM
		Wiring – Repairing broken circuits in landing light and any other wiring for non-required equipment such as electrical variometers or flight computers, excluding ignition system, primary generating system and required communication, navigation system and primary flight instruments.	Yes	Yes	Yes
		Bonding – Replacement of broken bonding cable.	Yes	Yes	Yes
		Switches – This includes soldering and crimping of non- required equipment such as electrical variometers or flight computers, but excluding ignition system, primary generating system and required communication, navigation system and primary flight instruments.	Yes	Yes	Yes
		Fuses – Replacement with the correct rating.	Yes	Yes	Yes
25	Equipment	Safety Belts – Replacement of safety belt and harnesses.	Yes	Yes	Yes
		Seats – Replacement of seats or seat parts not involving disassembly of any primary structure or control system.	Yes	Yes	Yes
		Non-essential instruments and/or equipment – Replacement of self contained, instrument panel mount equipment with quick disconnect connectors.	Yes	Yes	Yes
		Removal and installation of non-required instruments and/or equipment.	Yes	Yes	Yes
		Wing Wiper, Cleaner – Servicing, removal and reinstallation not involving disassembly or modification of any primary structure, control.	Yes	Yes	Yes
		Static Probes – Removal or reinstallation of variometer static and total energy compensation probes.	Yes	Yes	Yes
		Oxygen System – Replacement of portable oxygen bottles and systems in approved mountings, excluding permanently installed bottles and systems.	Yes	Yes	Yes
		Air Brake Chute – Installation and servicing	Yes	Yes	Yes
		ELT – Removal / Reinstallation.	Yes	Yes	Yes
26	Fire Protection	Fire Warning – Replacement of sensors and indicators.	N/A	Yes	Yes
27	Flight Control	Gap Seals – Installation and servicing if it does not require complete flight control removal.	Yes	Yes	Yes
		Control System – Measurement of the control system travel without removing the control surfaces.	Yes	Yes	Yes
		Control Cables – Simple optical Inspection for Condition.	Yes	Yes	Yes

ATA	Area	Task	SP	SSPS	SLPS / TM
		Gas Dampener – Replacement of Gas Dampener in the Control or Air Brake System.	Yes	Yes	Yes
		Co-pilot stick and pedals – Removal or reinstallation where provision for quick disconnect is made by design.	Yes	Yes	Yes
28	Fuel System	Fuel lines – Replacement of prefabricated fuel lines fitted with self-sealing couplings.	N/A	Yes	NO
		Fuel Filter – Cleaning and/or replacement.	N/A	Yes	Yes
31	Instruments	Instrument Panel– Removal and reinstallation provided this is a design feature with quick disconnect, excluding IFR operations.	Yes	Yes	Yes
		Pitot Static System – Simple sense and leak check.	Yes	Yes	Yes
		Instrument Panel vibration damper/shock absorbers- Replacement.	Yes	Yes	Yes
		Drainage – Drainage of water drainage traps or filters within the Pitot static system.	Yes	Yes	Yes
		Flexible tubes – Replacement of damaged tubes.	Yes	Yes	Yes
32	Landing Gear	Wheels – Removal, replacement and servicing, including replacement of wheel bearings and lubrication.	Yes	Yes	Yes
		Servicing – Replenishment of hydraulic fluid	Yes	Yes	Yes
		Shock Absorber – Replacement or servicing of elastic cords or rubber dampers.	Yes	Yes	Yes
		Shock Struts – Replenishment of oil or air.	Yes	Yes	Yes
		Landing gear doors – Removal or reinstallation and repair including operating straps.	Yes	Yes	Yes
		Skis – Changing between wheel and ski landing gear.	Yes	Yes	Yes
		Skids – Removal or reinstallation and servicing of main, wing and tail skids.	Yes	Yes	Yes
		Wheels fairing (spats) – Removal and reinstallation.	Yes	Yes	Yes
		Mechanical brakes – Adjustment of simple cable operated systems.	Yes	Yes	Yes
		Brake – Replacement of worn brake pads.	Yes	Yes	Yes
		Springs – Replacement of worn or aged springs.	Yes	Yes	Yes
		Gear Warning –Removal or reinstallation of simple gear warning systems.	Yes	Yes	Yes
33	Lights	Lights – Replacement of internal and external bulbs, filaments, reflectors and lenses.	N/A	N/A	Yes
34	Navigation	Software – Updating self contained, instrument panel mount navigational software databases, excluding automatic flight control systems and transponders and including update of non-required instruments/equipment.	Yes	Yes	Yes
		Navigation devices – Removal and replacement of self contained, instrument panel mount	Yes	Yes	Yes

ATA	Area	Task	SP	SSPS	SLPS / TM
		navigation devices with quick disconnect connectors, excluding automatic flight control systems, transponders, primary flight control system.			
		Self contained data logger – Installation, data restoration.	Yes	Yes	Yes
51	Structure	Fabric patches – Simple patches extending over not more than one rib and not requiring rib stitching or removal of structural parts or control surfaces.	Yes	Yes	Yes
		Protective Coating – Applying preservative material or coatings where no disassembly of any primary structure or operating system is involved.	Yes	Yes	Yes
		Surface finish – Minor restoration of paint or coating where the underlying primary structure is not affected. This includes application of signal coatings or thin foils as well as Registration markings.	Yes	Yes	Yes
		Fairings – Simple repairs to non-structural fairings and cover plates which do not change the contour.	Yes	Yes	Yes
52	Doors	Doors – Removal and reinstallation.	Yes	Yes	Yes
53	Fuselage	Upholstery, furnishing – Minor repairs which do not require disassembly of primary structure or operating systems, or interfere with control systems.	Yes	Yes	Yes
56	Windows	Side Windows – Replacement if it does not require riveting, bonding or any special process.	Yes	Yes	Yes
		Canopies – Removal and re-fitment.	Yes	Yes	Yes
		Gas dampener – Replacement of Canopy Gas dampener.	Yes	Yes	Yes
57	Wings	Wing Skids – Removal or reinstallation and service of lower wing skids or wing roller including spring assembly.	Yes	Yes	Yes
		Water ballast – Removal or reinstallation of flexible tanks.	Yes	Yes	Yes
		Turbulator and sealing tapes – Removal or reinstallation of approved sealing tapes and turbulator tapes.	Yes	Yes	Yes
61	Propeller	Spinner – Removal and reinstallation.	N/A	Yes	Yes
71	Powerplant installation	Removal or installation of Powerplant unit including engine and propeller.	N/A	Yes	NO
		Cowling – Removal and reinstallation not requiring removal of propeller or disconnection of flight controls.	N/A	Yes	Yes
		Induction System – Inspection and replacement of induction air filter.	N/A	Yes	Yes

ATA	Area	Task	SP	SSPS	SLPS / TM
72	Engine	Chip detectors – Removal, checking and reinstallation provided the chip detector is a self sealing type and not electrically indicated.	N/A	Yes	Yes
73	Engine fuel	Strainer or Filter elements – Cleaning and/or replacement.	N/A	Yes	Yes
		Fuel – Mixing of required oil into fuel.	N/A	Yes	Yes
74	Ignition	Spark Plugs – Removal, cleaning, adjustment and reinstallation.	N/A	Yes	Yes
75	Cooling	Coolant – Replenishment of coolant fluid.	N/A	Yes	Yes
76	Engine Controls	Controls – Minor adjustments of non-flight or propulsion controls whose operation is not critical for any phase of flight.	N/A	Yes	NO
77	Engine Indicating	Engine Indicating – Removal and replacement of self contained instrument panel mount indicators that have quick-release connectors and do not employ direct reading connections.	N/A	Yes	Yes
79	Oil System	Strainer or Filter elements – Cleaning and/or replacement.	N/A	Yes	Yes
		Oil – Changing or replenishment of engine oil and gearbox fluid.	N/A	Yes	Yes

Part D/ PILOT-OWNER MAINTENANCE TASKS for BALLOONS/AIRSHIPS

Area	Hot Air Airship	Hot Air Balloon	Gas Balloon
A) ENVELOPE			
1- Fabric repairs – excluding complete panels (as defined in, and in accordance with, Type Certificate holders’ instructions) not requiring load tape repair or replacement.	Yes	Yes	NO
2- Nose line – Replacement	Yes	N/A	N/A
3- Banners – fitment, replacement or repair (without sewing).	Yes	Yes	Yes
4- Melting link (temperature flag) – replacement.	Yes	Yes	N/A
5-Temperature transmitter and temperature indication cables – removal or reinstallation.	Yes	Yes	N/A
6- Crown line – replacement (where permanently attached to the crown ring).	No	Yes	N/A
7- Scoop or skirt-replacement or repair of (including fasteners).	Yes	Yes	N/A
B) BURNER			
8- Burner – cleaning and lubrication.	Yes	Yes	N/A
9- Piezo igniters – adjustment.	Yes	Yes	N/A
10- Burner jets – cleaning and replacement.	Yes	Yes	N/A
11- Burner frame corner buffers – replacement or reinstallation.	Yes	Yes	N/A
12- Burner Valves – adjustment of closing valve not requiring special tools or test equipment.	Yes	Yes	N/A
C) BASKET AND GONDOLA			
13- Basket/gondola frame trim – repair or replacement.	Yes	Yes	Yes
14- Basket/gondola runners (including wheels) – repair or replacement.	Yes	Yes	Yes
15- External rope handles – repair.	Yes	Yes	Yes
16- Replacement of seat covers – upholsteries and safety belts.	Yes	Yes	Yes
D) FUEL CYLINDER			
17- Liquid valve – replacement of O-rings in the outlet.	Yes	Yes	No
E) INSTRUMENTS AND EQUIPMENT			
18- Batteries – replacement of for self contained instruments and communication equipment.	Yes	Yes	Yes
19- Communication, navigation devices, instruments and/or equipment – Remove and replace self contained, instrument panel mounted communication devices with quick disconnect connectors.	Yes	Yes	Yes
F) ENGINES			
20- Cleaning and Lubrication not requiring disassembly other than removal of non-structural items such as cover plates, cowlings and fairings.	Yes	N/A	N/A
21- Cowling-removal and re-fitment not requiring removal of the propeller	Yes	N/A	N/A
22- Fuel and oil strainers and/or filter elements – Removal, cleaning and/or replacement	Yes	N/A	N/A
23- Batteries – replacing and servicing (excluding servicing of Ni-Cd batteries).	Yes	N/A	N/A

Area	Hot Air Airship	Hot Air Balloon	Gas Balloon
24- Propeller Spinner – removal and installation for inspection.	Yes	N/A	N/A
25- Powerplant – Removal or installation of powerplant unit including engine and propeller.	Yes	N/A	N/A
26- Engine- Chip detectors – remove, check and replace.	Yes	N/A	N/A
27- Ignition Spark Plug – removal or installation and adjustment including gap clearance.	Yes	N/A	N/A
28- Coolant fluid – replenishment.	Yes	N/A	N/A
29- Engine Controls – minor adjustments of non-flight or propulsion controls whose operation is not critical for any phase of flight.	Yes	N/A	N/A
30- Engine instruments – removal and replacement.	Yes	N/A	N/A
31- Lubrication oil – changing or replenishment of engine oil and gearbox fluid.	Yes	N/A	N/A
32- Fuel lines – replacement of prefabricated hoses with self-sealing couplings.	Yes	N/A	N/A
33- Air filters (if installed) – removal, cleaning and replacement.	Yes	N/A	N/A

APPENDICES TO THE AMC AND GM

Appendix I to AMC M.A.302 and AMC M.B.301(b) - Content of the maintenance programme

Note: For the purpose of this Appendix, references to CAMO should be understood as references to CAMO or CAO and references to MCAR-145 organisations should be understood as references to Subpart F or MCAR-CAO organisations.

1. General requirements

- 1.1 The maintenance programme should contain the following basic information.
 - 1.1.1. The type/model and registration number of the aircraft, engines and, where applicable, auxiliary power units and propellers
 - 1.1.2. The name and address of the owner, operator or CAMO managing the aircraft airworthiness.
 - 1.1.3. The reference, the date of issue and issue number of the approved maintenance programme.
 - 1.1.4. A statement signed by the owner, operator or CAMO managing the aircraft airworthiness to the effect that the specified aircraft will be maintained to the programme and that the programme will be reviewed and updated as required.
 - 1.1.5. Contents/list of effective pages and their revision status of the document.
 - 1.1.6. Check periods, which reflect the anticipated utilisation of the aircraft. Such utilisation should be stated and include a tolerance of not more than 25%. Where utilisation cannot be anticipated, calendar time limits should also be included.
 - 1.1.7. Procedures for the escalation of established check periods, where applicable and acceptable to the CAA.
 - 1.1.8. Provision to record the date and reference of approved amendments incorporated in the maintenance programme.
 - 1.1.9. Details of pre-flight maintenance tasks that are accomplished by maintenance staff.
 - 1.1.10. The tasks and the periods (intervals/frequencies) at which each part of the aircraft, engines, APU's, propellers, components, accessories, equipment, instruments, electrical and radio apparatus, together with the associated systems and installations should be inspected. This should include the type and degree of inspection required.
 - 1.1.11. The periods at which components should be checked, cleaned, lubricated, replenished, adjusted and tested.
 - 1.1.12. If applicable details of ageing aircraft system requirements together with any specified sampling programmes.
 - 1.1.13. If applicable, details of specific structural maintenance programmes including, but not limited to:
 - (a) (Supplemental) Structural Inspection Programmes (S)(SSIDs) Issued by the design approval holder.

- (b) Corrosion prevention and control programmes (CPCPs) taking into account the baseline CPCP issued by the design approval holder.
- (c) For large aeroplanes, maintenance data arising from compliance with the ageing structure requirements of MCAR-26.370.

1.1.14. If applicable, details of Critical Design Configuration Control Limitations together with appropriate procedures.

1.1.15. If applicable a statement of the limit of validity in terms of total flight cycles/calendar date/flight hours for the structural programme in 1.1.13.

1.1.16. The periods at which overhauls and/or replacements by new or overhauled components should be made.

1.1.17. A cross-reference to other documents approved by the state of design which contain the details of maintenance tasks related to mandatory life and inspection limitations, Certification Maintenance Requirements (CMRs) and ADs.

Note: To prevent inadvertent variations to such tasks or intervals, these items should not be included in the main portion of the maintenance programme document, or any planning control system, without specific identification of their mandatory status.

1.1.18. Details of, or cross-reference to, any required reliability programme or statistical methods of continuous Surveillance.

1.1.19. A statement that practices and procedures to satisfy the programme should be to the standards specified in the TC holder's Maintenance Instructions. In the case of approved practices and procedures that differ, the statement should refer to them.

1.1.20. Each maintenance task quoted should be defined in a definition section of the programme.

2. Programme basis

2.1 An owner or a CAMO aircraft maintenance programme should normally be based upon the MRB report, where applicable, and the TC holder's maintenance planning document or Chapter 5 of the maintenance manual, (i.e. the manufacturer's recommended maintenance programme).

The structure and format of these maintenance recommendations may be re-written by the owner or the CAMO to better suit the operation and control of the particular maintenance programme.

2.2 For a newly type-certificated aircraft where no previously approved maintenance programme exists, it will be necessary for the owner or the CAMO to comprehensively appraise the manufacturer's recommendations (and the MRB report where applicable), together with other airworthiness information, in order to produce a realistic programme for approval.

2.3 For existing aircraft types it is permissible for the owner or CAMO to make comparisons with maintenance programmes previously approved. It should not be assumed that a programme approved for one owner or the CAMO would automatically be approved for another.

Evaluation should be made of the aircraft/fleet utilisation, landing rate, equipment fit and, in particular, the experience of the owner or the CAMO when assessing an existing programme.

Where the CAA is not satisfied that the proposed maintenance programme can be used as is, the CAA should request appropriate changes such as additional maintenance tasks or de-escalation of check frequencies as necessary.

2.4 Critical Design Configuration Control Limitations (CDCCL)

If CDCCL have been identified for the aircraft type by the TC/STC holder, maintenance instructions should be developed. CDCCL's are characterised by features in an aircraft installation or component that should be retained during modification, change, repair, or scheduled maintenance for the operational life of the aircraft or applicable component or part.

3. Amendments

Amendments (revisions) to the approved maintenance programme should be made by the owner or the CAMO, to reflect changes in the TC holder's recommendations, modifications, service experience, or as required by the CAA.

4. Permitted variations to maintenance periods

The owner or the CAMO may only vary the periods prescribed by the programme with the approval of the CAA or through a procedure developed in the maintenance programme and approved by the CAA.

5. Periodic review of maintenance programme contents

- 5.1 The owner or the CAMO approved maintenance programmes should be subject to periodic review to ensure that they reflect current TC holder's recommendations, revisions to the MRB report if applicable, mandatory requirements and the maintenance needs of the aircraft.
- 5.2 The owner or the CAMO should review the detailed requirements at least annually for continued validity in the light of operating experience.

6. Reliability Programmes

6.1 Applicability

6.1.1 A reliability programme should be developed in the following cases:

- (a) the aircraft maintenance programme is based upon MSG-3 logic;
- (b) the aircraft maintenance programme includes condition monitored components;
- (c) the aircraft maintenance programme does not contain overhaul time periods for all significant system components;
- (d) when specified by the Manufacturer's maintenance planning document or MRB.

6.1.2 A reliability Programme need not be developed in the following cases:

- (a) the maintenance programme is based upon the MSG-1 or 2 logic but only contains hard time or on condition items
- (b) the aircraft is not a complex motor-powered aircraft according to MCAR-M
- (c) the aircraft maintenance programme provides overhaul time periods for all significant system components.
- (d) Note: for the purpose of this paragraph, a significant system is a system the failure of which could hazard the aircraft safety.

6.1.3 Notwithstanding paragraphs 6.1.1 and 6.1.2 above, a CAMO may however, develop its own reliability monitoring programme when it may be deemed beneficial from a maintenance planning point of view.

6.2 Applicability for CAMO/operator of small fleets of aircraft

6.2.1 For the purpose of this paragraph, a small fleet of aircraft is a fleet of less than 6 aircraft of the same type.

6.2.2 The requirement for a reliability programme is irrespective of the CAMO fleet size.

6.2.3 Complex reliability programmes could be inappropriate for a small fleet. It is recommended that such CAMOs tailor their reliability programmes to suit the size and complexity of operation.

6.2.4 One difficulty with a small fleet of aircraft consists in the amount of available data which can be processed: when this amount is too low, the calculation of alert level is very coarse. Therefore "alert levels" should be used carefully.

6.2.5 A CAMO of a small fleet of aircraft, when establishing a reliability programme, should consider the following:

- (a) The programme should focus on areas where a sufficient amount of data is likely to be processed.
- (b) When the amount of available data is very limited, the CAMO engineering judgement is then a vital element. In the following examples, careful engineering analysis should be exercised before taking decisions:
 - A "0" rate in the statistical calculation may possibly simply reveal that enough statistical data is missing, rather than there is no potential problem.
 - When alert levels are used, a single event may have the figures reach the alert level. Engineering judgement is necessary so as to discriminate an artefact from an actual need for a corrective action.

In making this engineering judgement, a CAMO is encouraged to establish contact and make comparisons with other CAMOs of the same aircraft, where possible and relevant. Making comparison with data provided by the manufacturer may also be possible.

6.2.6 In order to obtain accurate reliability data, it should be recommended to pool data and analysis with one or more other CAMO(s). Paragraph 6.6 of this paragraph specifies under which conditions it is acceptable that CAMOs share reliability data.

6.2.7 Notwithstanding the above there are cases where the CAMO will be unable to pool data with other CAMO, e.g. at the introduction to service of a new type. In that case the CAA should impose additional restrictions on the MRB/MPD tasks intervals (e.g. no variations or only minor evolution are possible, and with the CAA approval).

6.3 Engineering judgement

6.3.1 Engineering judgement is itself inherent to reliability programmes as no interpretation of data is possible without judgement. In approving the CAMO maintenance and reliability programmes, the CAA is expected to ensure that the organisation which runs the programme (it may be CAMO, or an MCAR-145 organisation under contract) hires sufficiently qualified personnel with appropriate engineering experience and understanding of reliability concept (see AMC M.A.706).

6.3.2 It follows that failure to provide appropriately qualified personnel for the reliability programme may lead the CAA to reject the approval of the reliability programme and therefore the aircraft maintenance programme.

6.4 Contracted maintenance

6.4.1 Whereas M.A.302 specifies that, the aircraft maintenance programme – which includes the associated reliability programme-, should be managed and presented by the CAMO to the CAA, the CAMO may subcontract certain functions to the maintenance organisation under contract, provided this organisation proves to have the appropriate expertise.

6.4.2 These functions are:

- (a) Developing the aircraft maintenance and reliability programmes,
- (b) Performing the collection and analysis of the reliability data,
- (c) Providing reliability reports, and
- (d) Proposing corrective actions to the CAMO.

6.4.3 Notwithstanding the above, decision to implement a corrective action (or the decision to request from the CAA the approval to implement a corrective action) remains the CAMO prerogative and responsibility. In relation to paragraph 6.4.2(d) above, a decision not to implement a corrective action should be justified and documented.

6.4.4 The arrangement between the CAMO and the maintenance organisation should be specified in the maintenance contract (see appendix XI to AMC M.A.708(c)) and the relevant CAME, and maintenance organisation procedures.

6.5 Reliability programme

In preparing the programme details, account should be taken of this paragraph. All associated procedures should be clearly defined.

6.5.1 Objectives.

6.5.1.1. A statement should be included summarising as precisely as possible the prime objectives of the programme. To the minimum it should include the following:

- (a) to recognise the need for corrective action,
- (b) to establish what corrective action is needed and,
- (c) to determine the effectiveness of that action

6.5.1.2. The extent of the objectives should be directly related to the scope of the programme. Its scope could vary from a component defect monitoring system for a small CAMO, to an integrated maintenance management programme for a big CAMO. The manufacturer's maintenance planning documents may give guidance on the objectives and should be consulted in every case.

6.5.1.3. In case of a MSG-3 based maintenance programme, the reliability programme should provide a monitor that all MSG-3 related tasks from the maintenance programme are effective and their periodicity is adequate.

6.5.2 Identification of items.

The items controlled by the programme should be stated, e.g. by ATA Chapters. Where some items (e.g. aircraft structure, engines, APU) are controlled by separate programmes, the associated procedures (e.g. individual sampling or life development programmes, constructor's structure sampling programmes) should be cross referenced in the programme.

6.5.3 Terms and definitions.

The significant terms and definitions applicable to the Programme should be clearly identified. Terms are already defined in MSG-3, MCAR-145 and MCAR-M.

6.5.4 Information sources and collection.

6.5.4.1 Sources of information should be listed and procedures for the transmission of information from the sources, together with the procedure for collecting and receiving it, should be set out in detail in the CAME or MOE as appropriate.

6.5.4.2 The type of information to be collected should be related to the objectives of the Programme and should be such that it enables both an overall broad based assessment of the information to be made and also allow for assessments to be made as to whether any reaction, both to trends and to individual events, is necessary. The following are examples of the normal prime sources:

- (a) Pilots Reports.

- (b) Technical Logs.
- (c) Aircraft Maintenance Access Terminal / On-board Maintenance System readouts.
- (d) Maintenance Worksheets.
- (e) Workshop Reports.
- (f) Reports on Functional Checks.
- (g) Reports on Special Inspections
- (h) Stores Issues/Reports.
- (i) Air Safety Reports.
- (j) Reports on Technical Delays and Incidents.
- (k) Other sources: ETOPS, RVSM, CAT II/III.

6.5.4.3 In addition to the normal prime sources of information, due account should be taken of continuing airworthiness and safety information promulgated under MCAR-21.

6.5.5 Display of information.

Collected information may be displayed graphically or in a tabular format or a combination of both. The rules governing any separation or discarding of information prior to incorporation into these formats should be stated. The format should be such that the identification of trends, specific highlights and related events would be readily apparent.

6.5.5.1 The above display of information should include provisions for "nil returns" to aid the examination of the total information.

6.5.5.2 Where "standards" or "alert levels" are included in the programme, the display of information should be oriented accordingly.

6.5.6 Examination, analysis and interpretation of the information.

The method employed for examining, analysing and interpreting the programme information should be explained.

6.5.6.1 Examination.

Methods of examination of information may be varied according to the content and quantity of information of individual programmes. These can range from examination of the initial indication of performance variations to formalised detailed procedures at specific periods, and the methods should be fully described in the programme documentation.

6.5.6.2 Analysis and Interpretation.

The procedures for analysis and interpretation of information should be such as to enable the performance of the items controlled by the programme to be measured; they should also facilitate recognition, diagnosis and recording of significant problems. The whole process should be such as to enable a critical assessment to be made of the effectiveness of the programme as a total activity. Such a process may involve:

- (a) Comparisons of operational reliability with established or allocated standards (in the initial period these could be obtained from in-service experience of similar equipment of aircraft types).
- (b) Analysis and interpretation of trends.
- (c) The evaluation of repetitive defects.
- (d) Confidence testing of expected and achieved results.
- (e) Studies of life-bands and survival characteristics.
- (f) Reliability predictions.
- (g) Other methods of assessment.

6.5.6.3 The range and depth of engineering analysis and interpretation should be related to the particular programme and to the facilities available. The following, at least, should be taken into account:

- (a) Flight defects and reductions in operational reliability.
- (b) Defects occurring on-line and at main base.
- (c) Deterioration observed during routine maintenance.
- (d) Workshop and overhaul facility findings.
- (e) Modification evaluations.
- (f) Sampling programmes.
- (g) The adequacy of maintenance equipment and publications.
- (h) The effectiveness of maintenance procedures.
- (i) Staff training.
- (j) Service bulletins, technical instructions, etc.

6.5.6.4 Where the CAMO relies upon contracted maintenance and/or overhaul facilities as an information input to the programme, the arrangements for availability and continuity of such information should be established and details should be included.

6.5.7 Corrective Actions.

6.5.7.1 The procedures and time scales both for implementing corrective actions and for monitoring the effects of corrective actions should be fully described. Corrective actions shall correct any reduction in reliability revealed by the programme and could take the form of:

- (a) Changes to maintenance, operational procedures or techniques.
- (b) Maintenance changes involving inspection frequency and content, function checks, overhaul requirements and time limits, which will require amendment of the scheduled maintenance periods or tasks in the approved maintenance programme. This may include escalation or de-escalation of tasks, addition, modification or deletion of tasks.
- (c) Amendments to approved manuals (e.g. maintenance manual, crew manual).
- (d) Initiation of modifications.
- (e) Special inspections of fleet campaigns.
- (f) Spares provisioning.
- (g) Staff training.
- (h) Manpower and equipment planning.

Note: Some of the above corrective actions may need the CAA approval before implementation.

6.5.7.2 The procedures for effecting changes to the maintenance programme should be described, and the associated documentation should include a planned completion date for each corrective action, where applicable.

6.5.8 Organisational Responsibilities.

The organisational structure and the department responsible for the administration of the programme should be stated. The chains of responsibility for individuals and departments (Engineering, Production, Quality, Operations etc.) in respect of the programme, together with the information and functions of any programme control committees (reliability group), should be defined. Participation of the CAA should be stated. This information should be contained in the CAME as appropriate.

6.5.9 Presentation of information to the CAA.

The following information should be submitted to the CAA for approval as part of the reliability programme:

- (a) The format and content of routine reports.
- (b) The time scales for the production of reports together with their distribution.

- (c) The format and content of reports supporting request for increases in periods between maintenance (escalation) and for amendments to the approved maintenance programme. These reports should contain sufficient detailed information to enable the CAA to make its own evaluation where necessary.

6.5.10 Evaluation and review.

Each programme should describe the procedures and individual responsibilities in respect of continuous monitoring of the effectiveness of the programme as a whole. The time periods and the procedures for both routine and non-routine reviews of maintenance control should be detailed (progressive, monthly, quarterly, or annual reviews, procedures following reliability “standards” or “alert levels” being exceeded, etc.).

6.5.10.1 Each Programme should contain procedures for monitoring and, as necessary, revising the reliability “standards” or “alert levels”. The organisational responsibilities for monitoring and revising the “standards” should be specified together with associated time scales.

6.5.10.2 Although not exclusive, the following list gives guidance on the criteria to be taken into account during the review.

- (a) Utilisation (high/low/seasonal).
- (b) Fleet commonality.
- (c) Alert Level adjustment criteria.
- (d) Adequacy of data.
- (e) Reliability procedure audit.
- (f) Staff training.
- (g) Operational and maintenance procedures.

6.5.11 Approval of maintenance programme amendment

The CAA may authorise the CAMO to implement in the maintenance programme changes arising from the reliability programme results prior to their formal approval by the authority when satisfied that;

- (a) the Reliability Programme monitors the content of the Maintenance Programme in a comprehensive manner, and
- (b) the procedures associated with the functioning of the “Reliability Group” provide the assurance that appropriate control is exercised by the CAMO over the internal validation of such changes.

6.6 Pooling Arrangements.

6.6.1 In some cases, in order that sufficient data may be analysed it may be desirable to 'pool' data: i.e. collate data from a number of CAMOs of the same type of aircraft. For the analysis to be valid, the aircraft concerned, mode of operation, and maintenance procedures applied should be substantially the same: variations in utilisation between two CAMOs may, more than anything, fundamentally corrupt the analysis. Although not exhaustive, the following list gives guidance on the primary factors which need to be taken into account.

- (a) Certification factors, such as: aircraft TCDS compliance (variant)/modification status, including SB compliance.
- (b) Operational Factors, such as: operational environment/utilisation, e.g. low/high/seasonal, etc./respective fleet size operating rules applicable (e.g. ETOPS/RVSM/All Weather etc.)/operating procedures/MEL and MEL utilisation.
- (c) Maintenance factors, such as: aircraft age maintenance procedures; maintenance standards applicable; lubrication procedures and programme; MPD revision or escalation applied or maintenance programme applicable.

6.6.2 Although it may not be necessary for all of the foregoing to be completely common, it is necessary for a substantial amount of commonality to prevail. Decision should be taken by the CAA on a case by case basis.

6.6.3 In case of a short term lease agreement (less than 6 month) more flexibility against the para 6.6.1 criteria may be granted by the CAA, so as to allow the owner/CAMO to operate the aircraft under the same programme during the lease agreement effectivity.

6.6.4 Changes by any one of the CAMO to the above, requires assessment in order that the pooling benefits can be maintained. Where a CAMO wishes to pool data in this way, the approval of the CAA should be sought prior to any formal agreement being signed between CAMOs.

6.6.5 Whereas this paragraph 6.6 is intended to address the pooling of data directly between CAMOs, it is acceptable that the CAMO participates in a reliability programme managed by the aircraft manufacturer, when the CAA is satisfied that the manufacturer manages a reliability programme which complies with the intent of this paragraph.

Appendix II to AMC M.A.711(a)(3) - Sub-contracting of continuing airworthiness management tasks

1. Subcontracted continuing airworthiness management tasks

- 1.1 To actively control the standards of the sub-contracted organisation, the CAMO should employ a person or group of persons who are trained and competent in the disciplines associated with M.A Subpart G. As such, they are responsible for determining what maintenance is required, when it has to be performed, by whom and to what standard in order to ensure the continued airworthiness of the aircraft to be operated.
- 1.2 The CAMO should conduct a pre-subcontract audit to establish that the organisation to be subcontracted can achieve the standards required by M.A Subpart G in connection with those activities to be subcontracted.
- 1.3 The CAMO should ensure that the organisation to be subcontracted has sufficient and qualified personnel who are trained and competent in the functions to be subcontracted. In assessing the adequacy of personnel resources, the CAMO should consider the particular needs of those activities that are to be subcontracted, while taking into account the subcontracted organisations existing commitments.
- 1.4 To be appropriately approved to subcontract continuing airworthiness management tasks, the CAMO should have procedures for the management control of these arrangements. The continuing airworthiness management exposition should contain relevant procedures to reflect its control of those arrangements made with the subcontracted organisation.
- 1.5 Subcontracted continuing airworthiness management tasks should be addressed in a contract between the CAMO and the subcontracted organisation. The contract should also specify that the subcontracted organisation is responsible for informing the CAMO, that is in turn responsible for notifying the CAA, of any subsequent changes that affect their ability to fulfil the contract.
- 1.6 The subcontracted organisation should use procedures which set out the manner of fulfilling its responsibilities with regard to the subcontracted activities. Such procedures may be developed by either the subcontracted organisation or the CAMO.
- 1.7 Where the subcontracted organisation develops its own procedures, they should be compatible with the continuing airworthiness management exposition and the terms of the contract. These should be accepted by the CAA as extended procedures of the CAMO and as such should be cross-referenced from the continuing airworthiness management exposition. One current copy of the subcontracted organisation's relevant procedures should be kept by the CAMO and should be accessible to the CAA when needed.

Note: Should any conflict arise between the subcontracted organisation's procedures and those of the CAMO, then the policy and procedures of the continuing airworthiness management exposition will prevail.

- 1.8 The contract should also specify that the subcontracted organisation's procedures may only be amended with the agreement of the CAMO. The CAMO should ensure that these amendments are compatible with their continuing airworthiness management exposition and comply with M.A Subpart G.

The CAMO should nominate the person responsible for continued monitoring and acceptance of the subcontracted organisation's procedures and their amendments. The controls used to fulfil this function should be clearly set out in the amendment section of the continuing airworthiness management exposition detailing the level of CAMO involvement.

- 1.9 Whenever any elements of continuing airworthiness management tasks are subcontracted, the CAMO personnel should have access to all relevant data in order to fulfil their responsibilities.

Note: The CAMO retains authority to override, whenever necessary for the continuing airworthiness of their aircraft, any recommendation of the subcontracted organisation.

- 1.10 The CAMO should ensure that the subcontracted organisation continues to have qualified technical expertise and sufficient resources to perform the subcontracted tasks while complying with the relevant procedures. Failure to do so may invalidate the CAMO approval.
- 1.11 The contract should provide for CAA monitoring.
- 1.12 The contract should address the respective responsibilities to ensure that any findings arising from the CAA monitoring will be closed to the satisfaction of the CAA.

2. ACCOMPLISHMENT

This paragraph describes topics, which may be applicable in such a subcontract arrangements.

2.1 Scope of work

The type of aircraft and their registrations, engine types and/or components subject to the continuing airworthiness management tasks contract should be specified.

2.2 Maintenance programme development and amendment

The CAMO may subcontract the preparation of the draft maintenance programme and any subsequent amendments. However, the CAMO remains responsible for assessing that the draft proposals meet its needs and obtaining CAA approval; the relevant procedures should specify these responsibilities. The contract should also stipulate that any data necessary to substantiate the approval of the initial programme or an amendment to this programme should be provided for CAMO agreement and/or CAA upon request.

2.3 Maintenance programme effectiveness and reliability

The CAMO should have a system in place to monitor and assess the effectiveness of the maintenance programme based on maintenance and operational experience. The collection of data and initial assessment may be made by the subcontracted organisation; the required actions are to be endorsed by the CAMO.

Where reliability monitoring is used to establish the effectiveness of the maintenance programme, this may be provided by the subcontracted organisation and should be specified in the relevant procedures. Reference should be made to the approved maintenance and reliability programme. Participation of the CAMO's personnel in reliability meetings with the subcontracted organisation should also be specified.

When providing reliability data, the subcontracted organisation is limited to working with primary data/documents provided by the CAMO or data provided by the CAMO's contracted maintenance organisation(s) from which the reports are derived. The pooling of reliability data is permitted if it is acceptable to the CAA.

2.4 Permitted variations to maintenance programme.

The reasons and justification for any proposed variation to scheduled maintenance may be prepared by the subcontracted organisation. Acceptance of the proposed variation should be granted by the CAMO. The means by which the CAMO acceptance is given should be specified in the relevant procedures. When outside the limits set out in the maintenance programme, the CAMO is required to obtain approval by the CAA.

2.5 Scheduled maintenance

Where the subcontracted organisation plans and defines maintenance checks or inspections in accordance with the approved maintenance programme, the required liaison with the CAMO, including feedback should be defined.

The planning control and documentation should be specified in the appropriate supporting procedures. These procedures should typically set out the CAMO's level of involvement in each type of check. This will normally involve the CAMO assessing and agreeing to a work specification on a case-by-case basis for base maintenance checks. For routine line maintenance checks, this may be controlled on a day-to-day basis by the subcontracted organisation subject to appropriate liaison and CAMO controls to ensure timely compliance. This may typically include, but is not necessarily limited to:

- applicable work package, including job cards,
- scheduled component removal list,
- ADs to be incorporated,
- modifications to be incorporated

The associated procedures should ensure that the CAMO is informed in a timely manner on the accomplishment of such tasks.

2.6 Quality monitoring

The CAMO's quality system should monitor the adequacy of the subcontracted continuing airworthiness management task performance for compliance with the contract and with M.A Subpart G. The terms of the contract should therefore include a provision allowing the CAMO to perform a quality surveillance (including audits) of the subcontracted organisation. The aim of the surveillance is primarily to investigate and judge the effectiveness of those subcontracted activities and thereby to ensure compliance with M.A Subpart G and the contract. Audit reports may be subject to review when requested by the CAA.

2.7 Access to the CAA

The contract should specify that the subcontracted organisation should always grant access to the CAA.

2.8 Maintenance data

The maintenance data used for the purpose of the contract should be specified, together with those responsible for providing such documentation and the competent authority responsible for the acceptance/approval of such data, when applicable. The CAMO should ensure that such data, including revisions, is readily available to the CAMO personnel and to those in the subcontracted organisation who may be required to assess such data. The CAMO should establish a 'fast track' means to ensure that urgent data is transmitted to the subcontractor in a timely manner. Maintenance data is defined in M.A.401(b) or ML.A.401(b).

2.9 Airworthiness directives (ADs)

While the various aspects of AD assessment, planning and follow-up may be accomplished by the subcontracted organisation, AD embodiment is performed by a maintenance organisation. The CAMO is responsible for ensuring timely embodiment of applicable ADs and is to be provided with notification of compliance. It, therefore, follows that the CAMO should have clear policies and procedures on AD embodiment supported by defined procedures which will ensure that the CAMO agrees to the proposed means of compliance.

The relevant procedures should specify:

- What information (e.g. AD publications, continuing airworthiness records, flight hours/cycles, etc.) the subcontracted organisation needs from the CAMO.
- What information (e.g. AD planning listing, detailed engineering order, etc) the CAMO needs from the subcontracted organisation in order to ensure timely compliance with the ADs.

To fulfil the above responsibility, the CAMO should ensure that it receives current mandatory continued airworthiness information for the aircraft and equipment it is managing.

2.10 Service bulletin (SB) modifications

The subcontracted organisation may be required to review and make recommendations on the embodiment of an SB and other associated non-mandatory material based on a clear policy established by the CAMO. This should be specified in the contract.

2.11 Mandatory life limitation or scheduled maintenance controls and component control/removal forecast

Where the subcontracted organisation performs planning activities, it should be specified that the organisation should be receive the current flight cycles; flight hours; landings and/or calendar controlled details, as applicable, at a frequency to be specified in the contract. The frequency should be such that it allows the organisation to properly perform the subcontracted planning functions. It, therefore, follows that there will need to be adequate liaison between the CAMO, the contracted maintenance organisation(s) and the

subcontracted organisation. Additionally, the contract should specify how the CAMO will be in possession of all current flight cycles, flight hours, etc., so that it may assure the timely accomplishment of the required maintenance.

2.12 Engine health monitoring

If the CAMO subcontracts the on-wing engine health monitoring, the subcontracted organisation should receive all the relevant information to perform this task, including any parameter reading deemed necessary to be supplied by the CAMO for this control. The contract should also specify what kind of feedback information (such as engine limitation, appropriate technical advice, etc.) the organisation should provide to the CAMO.

2.13 Defect control

Where the CAMO has subcontracted the day-to-day control of technical log deferred defects, this should be specified in the contract and should be adequately described in the appropriate procedures. The operator's MEL/CDL provides the basis for establishing which defects may be deferred and associated limits. The procedures should also define the responsibilities and actions to be taken for defects such as AOG situations, repetitive defects, and damage beyond the type certificate holder's limits.

For all other defects identified during maintenance, the information should be brought to the attention of the CAMO which, depending upon the procedural authority granted by the CAA, may determine that some defects can be deferred. Therefore, adequate liaison between the CAMO, its subcontracted organisation and contracted maintenance organisation should be ensured.

The subcontracted organisation should make a positive assessment of potential deferred defects and consider potential hazards arising from the cumulative effect of any combination of defects. The subcontracted organisations should liaise with the CAMO to get its agreement following this assessment.

Deferment of MEL/CDL allowable defects can be accomplished by a contracted maintenance organisation in compliance with the relevant technical log procedures, subject to the acceptance by the aircraft commander.

2.14 Mandatory occurrence reporting

All incidents and occurrences that meet the reporting criteria defined in MCAR-M and MCAR-145 should be reported as required by the respective requirements. The CAMO should ensure that adequate liaison exists with the subcontracted organisation and the maintenance organisation.

2.15 Continuing airworthiness records

They may be maintained and kept by the subcontracted organisation on behalf of the CAMO, which remains the owner of these documents. However, the CAMO should be provided with the current status of AD compliance and life-limited parts and time-controlled components in accordance with agreed procedures. The CAMO should also be granted unrestricted and timely access to original records as and when needed. Online access to the appropriate information systems is acceptable.

The record-keeping requirements of MCAR-M should be met. Access to the records by duly authorised members of the CAA should be granted upon request.

2.16 Maintenance check flight (MCF) procedures

MCFs are performed under the control of the operator in coordination with the CAMO. MCF requirements from the subcontracted organisation or contracted maintenance organisation should be agreed by the operator/CAMO.

2.17 Communication between the CAMO and the subcontracted organisation

2.17.1. In order to fulfil its airworthiness responsibility, the CAMO needs to receive all the relevant reports and relevant maintenance data. The contract should specify what information should be provided and when.

2.17.2. Meetings provide one important cornerstone whereby the CAMO can fulfil part of its responsibility for ensuring the airworthiness of the operated aircraft. They should be used to establish good communication between the CAMO, the subcontracted organisation and the contracted maintenance organisation. The terms of the contract should include, whenever appropriate, the provision for a certain number of meetings to be held between involved parties. Details of the types of liaison meetings and associated terms of reference of each meeting should be documented. The meetings may include but are not limited to all or a combination of:

(a) Contract review

Before the contract is enforced, it is very important that the technical personnel of both parties, that are involved in the fulfilment of the contract, meet in order to be sure that every point leads to a common understanding of the duties of both parties.

(b) Work scope planning meeting

Work scope planning meetings may be organised so that the tasks to be performed are commonly agreed.

(c) Technical meeting

Scheduled meetings should be organised in order to review on a regular basis and agree on actions on technical matters such as ADs, SBs, future modifications, major defects found during shop visit, reliability, etc...

(d) Quality meeting

Quality meetings should be organised in order to examine matters raised by the CAMO's quality surveillance and the CAA's monitoring activity and to agree upon necessary corrective actions.

(e) Reliability meeting

When a reliability programme exists, the contract should specify the involvement of the CAMO and of the subcontracted organisation in that programme, including their participation in reliability meetings. Provision to enable the CAA participation in the periodical reliability meetings should also be made.

Appendix III (Reserved)

Appendix IV to AMC M.A.604 - Maintenance Organisation Manual

1. Purpose

The maintenance organisation manual is the reference for all the work carried out by the approved maintenance organisation. It should contain all the means established by the organisation to ensure compliance with MCAR-M or MCAR-ML according to the extent of approval and the privileges granted to the organisation.

The maintenance organisation manual should define precisely the work that the approved maintenance organisation is authorised to carry out and the subcontracted work. It should detail the resources used by the organisation, its structure and its procedures.

2. Content

A typical Maintenance Organisation Manual for a small organisation (less than 10 maintenance staff) should be designed to be used directly on a day to day basis. The working documents and lists should be directly included into the manual. It should contain the following:

Part A - General

- **Table of contents**
- **List of effective pages**
- **Record of amendments**
- **Amendment procedure**
 - Drafting
 - Amendments requiring direct approval by the CAA
 - Approval
- **Distribution**
 - Name or title of each person holding a copy of the manual
- **Accountable manager statement**
 - Approval of the manual
 - Statement that the maintenance organisation manual and any incorporated document identified therein reflect the organisation's means of compliance with MCAR-M and MCAR-ML
 - Commitment to work according to the manual
 - Commitment to amend the manual when necessary

Part B — Description

- **Organisation’s scope of work**
 - Description of the work carried out by the organisation (type of product, type of work) and subcontracted work
 - Identification of the level of work which can be performed at each facility.
- **General presentation of the organisation**
 - Legal name and social status
- **Name and title of management personnel**
 - Accountable manager
 - Senior managers
 - Duties and responsibilities
- **Organisation chart**
- **Certifying staff and airworthiness review staff**
 - Minimum qualification and experience
 - List of authorised certifying staff and airworthiness review staff, their scope of qualification and the personal authorisation reference
- **Personnel**
 - Technical personnel (number, qualifications and experience)
 - Administrative personnel (number)
- **General description of the facility**
 - Geographical location (map)
 - Plan of hangars
 - Specialised workshops
 - Office accommodation
 - Stores
 - Availability of all leased facilities.

- **Tools, equipment and material**
 - List of tools, equipment and material used (including access to tools used on occasional basis)
 - Test apparatus
 - Calibration frequencies
- **Maintenance data**
 - List of maintenance data used in accordance with M.A.402 or ML.A.402, and appropriate amendment subscription information (including access to data used on occasional basis).

Part C — General Procedures

- **Organisational review**
 - Purpose (to insure that the approved maintenance organisation continues to meet the requirements of MCAR-M and MCAR-ML)
 - Responsibility
 - Organisation, frequency, scope and content (including processing of authority's findings)
 - Planning and performance of the review
 - Organisational review checklist and forms
 - Processing and correction of review findings
 - Reporting
 - Review of subcontracted work
- **Training**
 - Description of the methods used to ensure compliance with the personnel qualification and training requirements (certifying staff training, specialised training)
 - Description of the personnel records to be retained
- **Subcontracting of specialised services**
 - Selection criteria and control
 - Nature of subcontracted work

- List of subcontractors
- Nature of arrangements
- Assignment of responsibilities for the certification of the work performed
- **One time authorisations**
 - Maintenance checks
 - Certifying staff

Part D — Working Procedures

- **Work order acceptance**
- **Preparation and issue of the work package**
 - Control of the work order
 - Preparation of the planned work
 - Work package content (copy of forms, work cards, procedure for their use, distribution)
 - Responsibilities and signatures needed for the authorisation of the work
- **Logistics**
 - Persons/functions involved
 - Criteria for choosing suppliers
 - Procedures used for incoming inspection and storage of parts, tools and materials
 - Copy of forms and procedure for their use and distribution
- **Execution**
 - Persons/functions involved and respective role
 - Documentation (work package and work cards)
 - Copy of forms and procedure for their use and distribution
 - Use of work cards or manufacturer's documentation
 - Procedures for accepting components from stores including eligibility check
 - Procedures for returning unserviceable components to stores

- **Release to Service – Certifying staff**
 - Authorised certifying staff functions and responsibilities
- **Release to Service – Supervision**

Detailed description of the system used to ensure that all maintenance tasks, applicable to the work requested of the approved maintenance organisation, have been completed as required.

 - Supervision content
 - Copy of forms and procedure for their use and distribution
 - Control of the work package
- **Release to Service – Certificate of release to service**
 - Procedure for signing the CRS (including preliminary actions)
 - Certificate of release to service wording and standardised form
 - Completion of the aircraft continuing airworthiness record system
 - Completion of CAA Form 1
 - Incomplete maintenance
 - Maintenance check flight authorisation
 - Copy of CRS and CAA Form 1
- **Records**
- **Airworthiness review procedures and records for ELA1 aircraft not involved in commercial operations**
- **Special procedures**

Such as specialised tasks, disposal of unsalvageable components, re-certification of parts not having an CAA Form 1, etc.
- **Occurrence reporting**
 - Occurrences to be reported
 - Timeframe of reports
 - Information to be reported
 - Recipients

- **Management of indirect approval of the manual**
 - Amendments content eligible for indirect approval
 - Responsibility
 - Traceability
 - Information to the CAA
 - Final validation

Part E – Appendices

- **Sample of all documents used.**
- **List of maintenance locations.**
- **List of MCAR-145 or M.A. Subpart F organisations.**
- **List of subcontracted specialised services.**

3. Approval

The CAA should approve the manual in writing. This will normally be done by approving a list of effective pages.

Minor amendments, or amendments to a large capability list, can be approved indirectly, through a procedure approved by CAA.

4. Continuous compliance with MCAR-M and MCAR-ML

When a maintenance organisation manual no longer meets the requirements of this MCAR-M or MCAR-ML, whether through a change in MCAR-M or MCAR-ML, a change in the organisation or its activities, or through an inadequacy shown to exist by verification inspections conducted under the organisational review, or any other reason that affects the manuals conformity to requirements, the approved maintenance organisation is responsible to prepare and have approved an amendment to its manual.

5. Distribution

The manual describes how the organisation works therefore the manual or relevant parts thereof need to be distributed to all concerned staff in the organisation and contracted organisations.

Appendix V to AMC M.A.704 - Continuing airworthiness management exposition

The following text provides relevant information for developing a CAME for the particular case of a CAMO working on aircraft subject to MCAR-M and contracting maintenance to MCAR-M Subpart F and MCAR-145 organisations.

CONTINUING AIRWORTHINESS MANAGEMENT EXPOSITION (CAME) TABLE OF CONTENT

Part 0	General organisation
0.1	Corporate commitment by the accountable manager
0.2	General information
0.3	Management personnel
0.4	Management organisation chart
0.5	Procedure to notify the CAA of changes to the organisation's activities / approval / location / personnel
0.6	Exposition amendment procedures
Part 1	Continuing airworthiness management procedures
1.1	Aircraft technical log utilisation and MEL application
	Aircraft continuing airworthiness record system utilisation
1.2	Aircraft maintenance programmes – development, amendment and approval
1.3	Time and continuing airworthiness records, responsibilities, retention, access
1.4	Accomplishment and control of airworthiness directives
1.5	Analysis of the effectiveness of the maintenance programme(s)
1.6	Non-mandatory modification embodiment policy
1.7	Major repair and modification standards
1.8	Defect reports
1.9	Engineering activity
1.10	Reliability programmes
1.11	Pre-flight inspections
1.12	Aircraft weighing
1.13	Check flight procedures
Part 2	Quality system
2.1	Continuing airworthiness quality policy, plan and audits procedure
2.2	Monitoring of continuing airworthiness management activities
2.3	Monitoring of the effectiveness of the maintenance programme(s)
2.4	Monitoring that all maintenance is carried out by an appropriate maintenance organisation
2.5	Monitoring that all contracted maintenance is carried out in accordance with the contract, including subcontractors used by the maintenance contractor
2.6	Quality audit personnel
Part 3	Contracted Maintenance
3.1	Maintenance contractor selection procedure
3.2	Quality audit of aircraft
Part 4	Airworthiness review procedures
4.1	Airworthiness review staff
4.2	Review of aircraft records
4.3	Physical survey

- 4.4 Additional procedures for recommendations to CAA for the import of aircraft
- 4.5 Recommendations to the CAA for the issue of ARC
- 4.6 Issue of ARC
- 4.7 Airworthiness review records, responsibilities, retention and access

Part 4B Permit to fly procedures

- 4B.1 Conformity with approved flight conditions
- 4B.2 Issue of permit to fly under the CAMO privilege
- 4B.3 Permit to fly authorised signatories
- 4B.4 Interface with the CAA for the flight
- 4B.5 Permit to fly records, responsibilities, retention and access

Part 5 Appendices

- 5.1 Sample documents.
- 5.2 List of airworthiness review staff.
- 5.3 List of subcontractors as per M.A.711(a)(3).
- 5.4 List of contracted approved maintenance organisations.
- 5.5 Copy of contracts for subcontracted work (Appendix II to AMC M.A.711(a)(3)).

LIST OF EFFECTIVE PAGES

Page	Revision
1	Original
2	Original

Page	Revision
3	Original
4	Original

Page	Revision
5	Original
.....

DISTRIBUTION LIST

(The document should include a distribution list to ensure proper distribution of the manual and to demonstrate to the CAA that all personnel involved in continuing airworthiness activities have access to the relevant information. This does not mean that all personnel have to receive a manual, but that a reasonable amount of manuals is distributed within the organisation(s) so that personnel concerned have quick and easy access to the manual.

Accordingly, the continuing airworthiness management exposition should be distributed to:

- the operator's or the organisation's management personnel and any person at a lower level as necessary; and,
- the MCAR-145 or M.A. Subpart F contracted maintenance organisation(s); and,
- the CAA.)

PART 0 - GENERAL ORGANISATION

0.1 Corporate commitment by the accountable manager

(The accountable manager's exposition statement should embrace the intent of the following paragraph, and in fact this statement may be used without amendment. Any amendment to the statement should not alter its intent.)

This exposition defines the organisation and procedures upon which the M.A. Subpart G approval of Joe Bloggs under MCAR-M is based.

These procedures are approved by the undersigned and must be complied with, as applicable, in order to ensure that all continuing airworthiness activities, including maintenance of aircraft managed by Joe Bloggs, are carried out on time to an approved standard.

It is accepted that these procedures do not override the necessity of complying with any new or amended regulation published by the CAA from time to time where these new or amended regulations are in conflict with these procedures.

The CAA will approve this organisation whilst it is satisfied that the procedures are followed. It is understood that the CAA reserves the right to suspend, limit or revoke the M.A. Subpart G continuing airworthiness management approval of the organisation, as applicable, if the CAA has evidence that the procedures are not followed and the standards not upheld.

In the case of licenced air carriers, suspension or revocation of the approval of the M.A. Subpart G continuing airworthiness management organisation would invalidate the AOC.'

0.2 General Information

a) Brief description of the organisation

(This paragraph should describe broadly how the whole organisation [i.e. including the whole operator in the case of licenced air carriers or the whole organisation when other approvals are held] is organised under the management of the accountable manager, and should refer to the organisation charts of paragraph 0.4.)

b) Relationship with other organisations

(This paragraph may not be applicable to every organisation.)

(1) Subsidiaries / mother company

(For clarity purpose, where the organisation belongs to a group, this paragraph should explain the specific relationship the organisation may have with other members of that group, e.g. links between Joe Bloggs Airlines, Joe Bloggs Finance, Joe Bloggs Leasing, Joe Bloggs Maintenance, etc...)

(2) Consortia

(Where the organisation belongs to a consortium, it should be indicated here. The other members of the consortium should be specified, as well as the scope of organisation of the

consortium [e.g. operations, maintenance, design (modifications and repairs), production etc...]. The reason for specifying this is that consortium maintenance may be controlled through specific contracts and through consortium’s policy and/or procedures manuals that might unintentionally override the maintenance contracts. In addition, in respect of international consortia, the respective competent authorities should be consulted and their agreement to the arrangement should be clearly stated. This paragraph should then make reference to any consortium’s continuing airworthiness related manual or procedure and to any competent authority agreement that would apply.)

c) Scope of work - Aircraft managed

(This paragraph should specify the scope of the work for which the CAMO is approved. This paragraph may include aircraft types/series, aircraft registrations, owner/operator, contract references, etc. The following is given as an example :)

Aircraft type/series	Date included in the scope of work	Aircraft maintenance programme or “generic/base line” maintenance programme	Aircraft registration(s)	Owner/operator	CAMO contract reference

For licenced air carriers, this paragraph can make reference to the operations specifications or operations manual where the aircraft registrations are listed.

(Depending on the number of aircraft, this paragraph may be updated as follows:

- 1) *the paragraph is revised each time an aircraft is removed from or added in the list.*
- 2) *the paragraph is revised each time a type of aircraft or a significant number of aircraft is removed from or added to the list; in that case, the paragraph should explain where the current list of aircraft managed is available for consultation.)*

d) Type of operation

(This paragraph should give broad information on the type of operations such as: commercial air transport operations, (commercial) specialised operations, training organisation, NCC, NCO, long haul/short haul/regional, scheduled/charter, regions / countries / continents flown, etc)

0.3 Management personnel

a) Accountable manager

(This paragraph should address the duties and responsibilities of the accountable manager as regards M.A. Subpart G approvals and should demonstrate that he/she has corporate authority for ensuring that all continuing airworthiness activities can be financed and carried out to the required standard.)

- b) Nominated post holder for continuing airworthiness referred to in M.A.706(d)

(This paragraph should:

- *emphasise that the nominated postholder for continuing airworthiness is responsible to ensure that all maintenance is carried out on time to an approved standard; and*
- *describe the extent of his/her authority as regards his/her MCAR-M responsibility for continuing airworthiness.*

- c) Continuing airworthiness coordination

(This paragraph should list in sufficient detail the job functions that constitute the “group of persons” as required by M.A.706(c) so as to show that all the continuing airworthiness responsibilities as described in MCAR-M are covered by the persons that constitute that group. In the case of small operators where the “nominated post-holder” for continuing airworthiness constitutes himself/herself the “group of persons”, this paragraph may be merged with the previous one.)

- d) Duties and responsibilities

(This paragraph should further elaborate the duties and responsibilities of all the nominated persons and of any other management personnel.)

- e) Manpower resources and training policy

(1) Manpower resources

(This paragraph should give broad figures to show that the number of people assigned to the performance of the approved continuing airworthiness activity is adequate. It is not necessary to give the detailed number of employees of the whole company, but only the number of those involved in continuing airworthiness. This could be presented as follows:)

As of 28 November 2003, the number of employees assigned to the performance of the continuing airworthiness management system is the following:

	Full-time	Part-time in equivalent full-time
Quality monitoring	AA	aa = AA'
Continuing airworthiness management	BB	bb = BB'
(Detailed information about the	BB1	bb1 = BB1'
Management of group of persons)	BB2	bb2 = BB2'
Other...	CC	cc = CC'
Total	TT	tt = TT'
Total man-hours	TT + TT'	

(Note: According to the size and complexity of the organisation, this table may be further developed or simplified)

(2) Training policy

(This paragraph should show that the training and qualification standards for the personnel mentioned above are consistent with the size and complexity of the organisation. It should also explain how the need for recurrent training is assessed and how the training recording and follow-up is performed)

0.4 Management organisation charts

a) General organisation chart

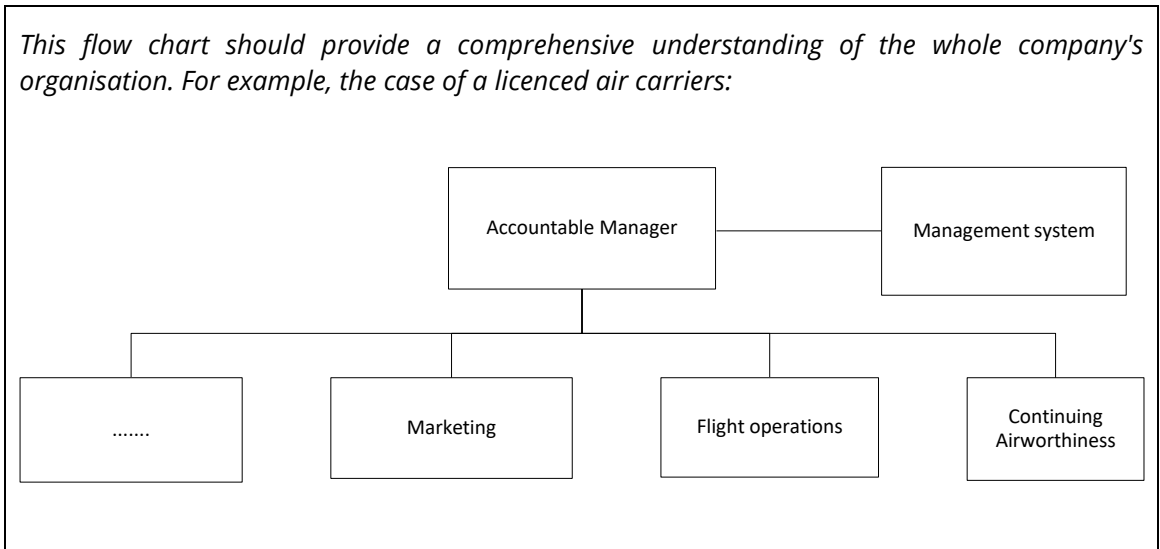

b) Continuing airworthiness management organisation chart

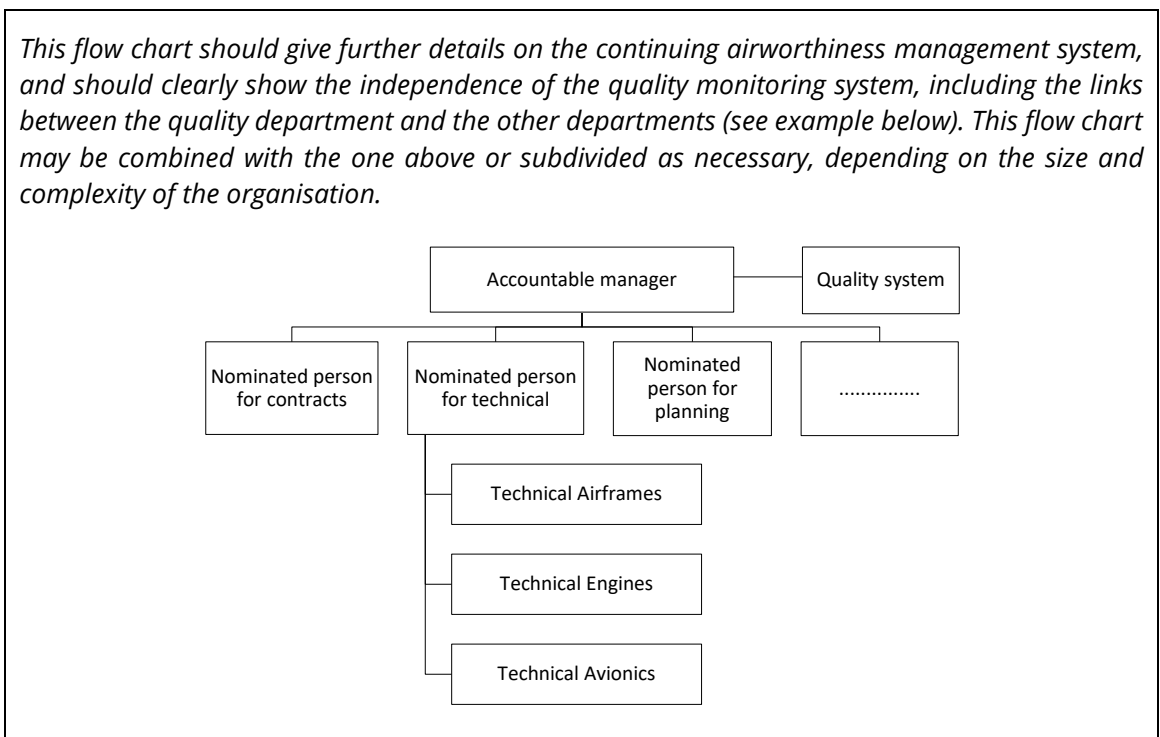

0.5 Procedure to notify the CAA of changes to the organisation's activities / approval / location / personnel

(This paragraph should explain the cases where the company should inform the CAA prior to incorporating proposed changes, for instance:

The accountable manager (or any nominated person such as the nominated postholder or the quality manager) will notify the CAA of any change concerning:

- (1) the company's name and location(s)*
- (2) the group of persons as specified in paragraph 0.3.c); and*
- (3) operations, procedures and technical arrangements, as far as they may affect the approval.*

Joe Bloggs will not incorporate such changes until they have been assessed and approved by the CAA.)

0.6 Exposition amendment procedure

(This paragraph should explain who is responsible for the amendment of the exposition and its submission to the CAA for approval. This may include, if agreed by the CAA, the possibility for the approved organisation to approve internally minor amendments that have no impact on the approval held. The paragraph should then specify what types of amendments are considered as minor and major, and what the approval procedures for both cases are.)

PART 1 - CONTINUING AIRWORTHINESS MANAGEMENT PROCEDURES

1.1 Aircraft technical log utilisation and MEL application

or

1.1 Aircraft continuing airworthiness record system utilisation

a) Aircraft technical log and/or continuing airworthiness record system

(1) General

(It may be useful to recall, in this introductory paragraph, the purpose of the aircraft technical log system and/or continuing airworthiness record system, with special attention to the options of M.A.305 and M.A.306.

For that purpose, the paragraphs of M.A.305 and M.A.306 may be quoted or further explained.)

(2) Instructions for use

(This paragraph should provide instructions for using the aircraft technical log and/or continuing airworthiness record system. It should emphasise the respective responsibilities of the maintenance personnel and operating crew. Samples of the technical log and/or continuing airworthiness record system should be included in Part 5 "Appendices" in order to provide enough detailed instructions.)

(3) Aircraft technical log approval

(This paragraph should explain who is responsible for submitting the aircraft technical log, and any subsequent amendment thereto, to the CAA for approval and what is the procedure to be followed.)

b) MEL application

(The MEL is a document not controlled by the CAMO and the decision of whether accepting or not the operation with a defect deferred in accordance with the MEL is normally the responsibility of the operating crew. This paragraph should explain in sufficient detail the MEL application procedure, because the MEL is a tool that the personnel involved in continuing airworthiness and maintenance have to be familiar with in order to ensure proper and efficient communication with the crew in case of a defect rectification to be deferred.)

(This paragraph does not apply to those types of aircraft that do not have an MEL)

(1) General

(This paragraph should explain broadly what a MEL document is. The information could be extracted from the aircraft flight manual.)

(2) MEL categories

(Where an owner/operator uses a classification system placing a time constraint on the rectification of defects, it should be explained here what are the general principles of such a

system. It is essential for the personnel involved in continuing airworthiness and maintenance to be familiar with it for the management of MEL's deferred defect rectification.)

(3) Application

(This paragraph should explain how the continuing airworthiness and maintenance personnel make the flight crew aware of an MEL limitation. This should refer to the technical log procedures)

(4) Acceptance by the crew

(This paragraph should explain how the crew notifies their acceptance or non-acceptance of the MEL deferral in the technical log)

(5) Management of the MEL time limits

(Once a technical limitation is accepted by the crew, the defect must be rectified within the time limit specified in the MEL. There should be a system to ensure that the defect will actually be rectified before that time limit. This system could be the aircraft technical log for those [small] operators that use it as a planning document, or a specific follow-up system where control of the maintenance time limit is ensured by other means such as data processed planning systems.)

(6) MEL time limitation overrun

(The CAA may allow the owner/operator to overrun MEL time limitation under specific conditions. Where applicable, this paragraph should describe the specific duties and responsibilities with regard to controlling these extensions.)

1.2 Aircraft maintenance programme - development and amendment

a) General

(This introductory paragraph should recall that the purpose of a maintenance programme is to provide maintenance planning instructions necessary for the safe operation of the aircraft.)

b) Content

(This paragraph should explain what is [are] the format[s] of the aircraft maintenance programme[s]. Appendix 1 to AMC M.A.302 (a) should be used as a guideline to develop this paragraph.)

c) Development

(1) Sources

(This paragraph should explain what are the sources [MRB, MPD, Maintenance Manual, etc..] used for the development of an aircraft maintenance programme.)

(2) Responsibilities

(This paragraph should explain who is responsible for the development of an aircraft maintenance programme)

(3) Manual amendments

(This paragraph should demonstrate that there is a system for ensuring the continuing validity of the aircraft maintenance programme. Particularly, it should show how any relevant information is used to update the aircraft maintenance programme. This should include, as applicable, MRB report revisions, consequences of modifications, manufacturer and CAA recommendations, in service experience, and reliability reports.)

(4) Acceptance by the authority

(This paragraph should explain who is responsible for the submission of the maintenance programme to the CAA and what the procedure to follow is. This should in particular address the issue of the approval for variation to maintenance periods either by the CAA or by a procedure in the maintenance programme for the organisation to approve internally certain changes.)

1.3 Time and continuing airworthiness records, responsibilities, retention and access

a) Hours and cycles recording

(The recording of flight hours and cycles is essential for the planning of maintenance tasks. This paragraph should explain how the continuing airworthiness management organisation has access to the current flight hours and cycles information and how it is processed through the organisation.)

b) Records

(This paragraph should give in detail the type of company documents that are required to be recorded and what are the recording period requirements for each of them. This can be provided by a table or series of tables that would include the following:

- Family of document [if necessary],
- Name of document,
- Retention period,
- Responsible person for retention,
- Place of retention,)

c) Preservation of records

(This paragraph should set out the means provided to protect the records from fire, floods, etc.. as well as the specific procedures in place to ensure that the records will not be altered during the retention period [especially computer records].)

- d) Transfer of continuing airworthiness records

(This paragraph should set out the procedure for the transfer of records, in case of purchase/lease-in, sale/lease-out and transfer of an aircraft to another organisation. In particular, it should specify which records have to be transferred and who is responsible for the coordination [if necessary] of the transfer.)

1.4 Accomplishment and control of Airworthiness Directives

(This paragraph should demonstrate that there is a comprehensive system in place for the management of airworthiness directives. This paragraph may, for instance, include the following subparagraphs:)

- a) Airworthiness directive information

(This paragraph should explain what the AD information sources are and who receives them in the company. Where available, multiple sources [e.g. CAA of state of design + CAA + manufacturer or association] may be useful.)

- b) Airworthiness directive decision

(This paragraph should explain how and by whom the AD information is analysed and what kind of information is provided to the contracted maintenance organisations in order to plan and perform the airworthiness directive. This should include as necessary a specific procedure for the management of emergency airworthiness directives)

- c) Airworthiness directive control

(This paragraph should specify how the organisation manages to ensure that all the applicable airworthiness directives are accomplished and that they are accomplished on time. This should include a closed-loop system that allows verifying that for each new or revised airworthiness directive and for each aircraft:

- *the AD is not applicable or,*
- *if the AD is applicable:*
 - *the AD is not yet accomplished but the time limit is not overdue,*
 - *the AD is accomplished, and any repetitive inspection is identified and performed.*

This may be a continuous process or may be based on scheduled reviews.)

1.5 Analysis of the effectiveness of the maintenance programme

(this paragraph should show what tools are used in order to analyse the efficiency of the maintenance programme, such as:

- *pilot report (PIREPS),*
- *air turnbacks*

- spare consumption,
- repetitive technical occurrence and defect,
- technical delays analysis [through statistics, if relevant],
- technical incidents analysis [through statistics, if relevant],
- etc...

This paragraph should also indicate by whom and how this data is analysed, what is the decision process to take action and what kind of action could be taken. This may include:

- amendment of the maintenance programme,
- amendment of maintenance or operational procedures,
- etc...)

1.6 Non-mandatory modification embodiment policy

(This paragraph should specify how the non-mandatory modification information is processed through the organisation, who is responsible for its assessment against the operator's/owner's own needs and operational experience, what are the main criteria for decision and who takes the decision of implementing [or not] a non-mandatory modification)

1.7 Major repair and modification standards

(This paragraph should set out a procedure for the assessment of the approval status of any major repair or modification before embodiment. This will include the assessment of the need of CAA or design organisation approval. It should also identify the type of approval required, and the procedure to follow to have a repair or modification approved by the CAA or design organisation.)

1.8 Defect reports

a) Analysis

(This paragraph should explain how the defect reports provided by the contracted maintenance organisations are processed by the continuing airworthiness management organisation. Analysis should be conducted in order to give elements to activities such as maintenance programme evolution and non-mandatory modification policy.)

b) Liaison with manufacturers and regulatory authorities

(Where a defect report shows that such defect is likely to occur to other aircraft, a liaison should be established with the manufacturer and the certification competent authority so that they may take all the necessary action.)

c) Deferred defect policy

(Defects such as cracks and structural defect are not addressed in the MEL and CDL. However, it may be necessary in certain cases to defer the rectification of a defect. This paragraph should establish the procedure to be followed in order to be sure that the deferment of any defect will not lead to any safety concern. This will include appropriate liaison with the manufacturer.)

1.9 Engineering activity

(Where applicable, this paragraph should present the scope of the organisation's engineering activity in terms of approval of modifications and repairs. It should set out a procedure for developing and submitting a modification/repair design for approval to the CAA and include reference to the supporting documentation and forms used. It should identify the person in charge of accepting the design before submission to the CAA.

(Where the organisation has a DOA capability under EASA Part 21, it should be indicated here and the related manuals should be referred to.)

1.10 Reliability programmes

(This paragraph should explain appropriately the management of a reliability programme. It should at least address the following:

- *extent and scope of the reliability programme,*
- *specific organisational structure, duties and responsibilities,*
- *establishment of reliability data,*
- *analysis of the reliability data,*
- *corrective action system (maintenance programme amendment),*
- *scheduled reviews (reliability meetings and when the participation of the CAA is needed.)*

(This paragraph may, where necessary, be subdivided as follows:)

- a) Airframe
- b) Propulsion
- c) Component

1.11 Pre-flight inspections

(This paragraph should show how the scope and definition of pre-flight inspection, that is usually performed by the operating crew, are kept consistent with the scope of the maintenance performed by the contracted maintenance organisations. It should show how the evolution of the content of the pre-flight inspection and of the maintenance programme are concurrent.)

(The following paragraphs are self-explanatory. Although these activities are normally not performed by continuing airworthiness personnel, these paragraphs have been placed here in order to ensure that the related procedures are consistent with the continuing airworthiness activity procedures.)

- a) Preparation of aircraft for flight
- b) Subcontracted ground handling function
- c) Security of Cargo and Baggage loading
- d) Control of refueling, Quantity/Quality
- e) Control of snow, ice, residues from de-icing or anti-icing operations, dust and sand contamination to an approved standard

1.12 Aircraft weighing

(This paragraph should state the cases where an aircraft has to be weighed [for instance, after a major modification because of weight and balance operational requirements, etc.], who performs it, according to which procedure, who calculates the new weight and balance, and how the result is processed in the organisation.)

1.13 Maintenance check flight (MCF) procedures

(The criteria for performing a MCF are normally included in the aircraft maintenance programme or derived by the scenarios described in GM M.A.301(i). This paragraph should explain how the MCF procedure is established in order to meet its intended purpose [for instance, after a heavy maintenance check, after engine or flight control removal installation, etc.], and the release procedures to authorise such an MCF.)

PART 2 - QUALITY SYSTEM

2.1 Continuing airworthiness quality policy, plan and audit procedure

- a) Continuing airworthiness quality policy

(This paragraph should include a formal Quality Policy statement - that is a commitment to what the Quality System is intended to achieve. It should include as a minimum the monitoring of compliance with MCAR-M and with any additional standards specified by the organisation.)

- b) Continuing airworthiness quality plan

(This paragraph should show how the quality plan is established. The quality plan will consist of a quality audit and sampling schedule that should cover all the areas specific to MCAR-M in a definite period of time. However, the scheduling process should also be dynamic and allow for special evaluations when trends or concerns are identified. In case of subcontracting, this paragraph should also address the planning of the auditing of subcontractors at the same frequency with the rest of the organisation.)

- c) Continuing airworthiness quality audit procedure

(Quality audit is a key element of the quality system. Therefore, the quality audit procedure should be sufficiently detailed to address all the steps of an audit from preparation to conclusion; it should show the audit report format [e.g. by reference to paragraph 5.1 "sample of document"], and should explain the rules for the distribution of audits reports in the organisation [e.g.: involvement of the Quality Manager, Accountable Manager, Nominated Postholder, etc...].)

- d) Continuing airworthiness quality audit remedial action procedure

(This paragraph should explain what system is put in place in order to ensure that the corrective actions are implemented on time and that the result of the corrective actions meets the intended purpose. For instance, where this system consists in periodical corrective actions review, instructions should be given how such reviews should be conducted and what should be evaluated.)

2.2 Monitoring of continuing airworthiness management activities

(This paragraph should set out a procedure to periodically review the activities of the continuing airworthiness management personnel and how they fulfil their responsibilities, as defined in Part 0.)

2.3 Monitoring of the effectiveness of the maintenance programme(s)

(This paragraph should set out a procedure to periodically review that the effectiveness of the maintenance programme(s) is actually analysed as defined in Part 1.)

2.4 Monitoring that all maintenance is carried out by an appropriate maintenance organisation

(This paragraph should set out a procedure to periodically review that the approval of the contracted maintenance organisations is relevant for the maintenance of the operator's fleet. This may include feedback information from any contracted organisation on any actual or contemplated amendment in order to ensure that the maintenance system remains valid and to anticipate any necessary change in the maintenance agreements.

If necessary, the procedure may be subdivided as follows:

- a) Aircraft maintenance
- b) Engines
- c) Components)

2.5 Monitoring that all contracted maintenance is carried out in accordance with the contract, including subcontractors used by the maintenance contractor

(This paragraph should set out a procedure to periodically review that the continuing airworthiness management personnel are satisfied that all contracted maintenance is carried out in accordance with the contract. This may include a procedure to ensure that the system allows all the personnel involved in the contract (including the contractors and their subcontractors) to familiarise themselves with its terms and that, for any contract amendment, relevant information is distributed in the organisation and to the contractor.)

2.6 Quality audit personnel

(This paragraph should establish the required training and qualification standards for auditors. Where persons act as part-time auditors, it should be emphasised that they must not be directly involved in the activity they are auditing.)

PART 3 - CONTRACTED MAINTENANCE

3.1 Procedures for contracted maintenance

- a) Procedures for the development of maintenance contracts

(This paragraph should explain the procedures that the organisation follows to develop the maintenance contract. The CAMO processes to implement the different elements described in Appendix XI to AMC M.A.708(c) should be explained. In particular, it should cover responsibilities, tasks and interaction with the maintenance organisation and with the owner/operator.

This paragraph should also describe, when necessary, the use of work orders for unscheduled line maintenance and component maintenance as per M.A.708(d). The organisation may develop a work order template to ensure that the applicable elements of Appendix XI to AMC M.A.708(c) are considered. Such a template should be included in Part 5.1.)

- b) Maintenance contractor selection procedure

(This paragraph should explain how a maintenance contractor is selected by the CAMO. Selection should not be limited to the verification that the contractor is appropriately approved for the specific type of aircraft, but also that the contractor has the industrial capacity to undertake the required maintenance. The selection procedure should preferably include a contract review process in order to ensure that:

- the contract is comprehensive and that it has no gaps or unclear areas,*
- everyone involved in the contract [both at the continuing airworthiness management organisation and at the maintenance contractor] agrees with the terms of the contract and fully understands their responsibilities.*
- that functional responsibilities of all parties are clearly identified.*

The CAMO should agree with the operator on the process to select a maintenance organisation before concluding any contract with a maintenance organisation.)

3.2 Quality audit of aircraft

(This paragraph should set out the procedure when performing a quality audit of an aircraft. It should set out the differences between an airworthiness review and a quality audit. This procedure may include:

- compliance with approved procedures;*
- contracted maintenance is carried out in accordance with the contract;*
- continued compliance with MCAR-M.)*

PART 4 - AIRWORTHINESS REVIEW PROCEDURES

4.1 Airworthiness review staff

(This paragraph should establish the working procedures for the assessment of the airworthiness review staff. The assessment addresses experience, qualification, training, etc. A description should be given regarding the issuance of authorisations for the airworthiness review staff and how records are kept and maintained.)

4.2 Review of aircraft records

(This paragraph should describe in detail the aircraft records that are required to be reviewed during the airworthiness review. The level of detail that needs to be reviewed as well as the number of records that needs to be reviewed during a sample check should be described.)

4.3 Physical survey

(This paragraph should describe how the physical survey needs to be performed. It should list the topics that need to be reviewed, the physical areas of the aircraft to be inspected, which documents on board the aircraft that need to be reviewed, etc.)

4.4 Additional procedures for recommendations to CAA for the import of aircraft

(This paragraph should describe the additional tasks regarding the recommendation for the issuance of an airworthiness review certificate in the case of import of aircraft. This should include: communication with the CAA, additional items to be reviewed during the airworthiness review of the aircraft, specification of maintenance required to be carried out, etc.)

4.5 Recommendations to the CAA for the issue of airworthiness review certificates (ARCs)

(This paragraph should stipulate the communication procedures with the CAA in case of a recommendation for the issuance of an airworthiness review certificate. In addition, the content of the recommendation should be described.)

4.6 Issuance of airworthiness review certificates (ARCs)

(This paragraph should set out the procedure for the issuance of the ARCs. It should address record-keeping, distribution of the ARC copies, etc. The procedure should ensure that an ARC is issued only after an airworthiness review that has been properly carried out.)

4.7 Airworthiness review records, responsibilities, retention and access

(This paragraph should describe how records are kept, duration of record-keeping, location where records are stored, access to records– and responsibilities.)

PART 4B - PERMIT TO FLY PROCEDURES

4B.1 Conformity with approved flight conditions

(The procedure should indicate how conformity with approved flight conditions is established, documented and attested by an authorised person.)

4B.2 Issue of the permit to fly under the CAMO privilege

(The procedure should describe the process to complete the CAA Form 20b (see Appendix IV to MCAR-21) and how compliance with 21.A.711(d) and (e) is established before signing off the permit to fly. It should also describe how the organisation ensures compliance with 21.A.711(g) for the revocation of the permit to fly)

4B.3 Permit to fly authorised signatories

(The person(s) authorised to sign off the permit to fly under the privilege of M.A.711(c) should be identified (name, signature and scope of authority) in the procedure, or in an appropriate document linked to the CAME.)

4B.4 Interface with the local authority for the flight

(The procedure should include provisions describing the communication with the local authority for flight clearance and compliance with the local requirements, since those elements are outside the scope of the conditions of 21.A.708(b) (see MCAR 21.A.711(e))

4B.5 Permit to fly records, responsibilities, retention and access

(This paragraph should describe how records are kept, duration of record-keeping, location where records are stored, access to records, and responsibilities.)

PART 5 - APPENDICES

5.1 Sample documents

(A self-explanatory paragraph)

5.2 List of airworthiness review staff

(A self-explanatory paragraph)

5.3 List of subcontractors as per AMC M.A.711(a)(3).

(A self-explanatory paragraph; in addition it should set out that the list should be periodically reviewed.)

5.4 List of approved maintenance organisations contracted

(This paragraph should include the list of contracted maintenance organisations, detailing the scope of the contracted work. In addition, it should set out that the list should be periodically reviewed)

5.5 Copy of contracts for subcontracted work (Appendix II to AMC M.A.711(a)(3))

(A self-explanatory paragraph)

Appendix VI (Reserved)

Appendix VII (Reserved)

Appendix VIII to AMC M.A.616 - Organisational Review

This is only applicable to organisations with less than 10 maintenance staff members. For larger organisations, the principles and practices of an independent quality system should be used.

Depending on the complexity of the small organisation (number and type of aircraft, number of different fleets, subcontracting of specialised services, etc.), the organisational review system may vary from a system using the principles and practices of a quality system (except for the requirement of independence) to a simplified system adapted to the low complexity of the organisation and the aircraft managed.

As a core minimum, the organisational review system should have the following features, which should be described in the Maintenance Organisation Manual (MOM):

- a. Identification of the person responsible for the organisational review programme.

By default, this person should be the accountable manager, unless he delegates this responsibility to (one of) the M.A.606(b) person(s).

- b. Identification and qualification criteria for the person(s) responsible for performing the organisational reviews.

These persons should have a thorough knowledge of the regulations and of the maintenance organisation procedures. They should also have knowledge of audits, acquired through training or through experience (preferably as an auditor, but also possibly because they actively participated in several audits conducted by the CAA).

- c. Elaboration of the organisational review programme:

- Checklist(s) covering all items necessary to be satisfied that the organisation delivers a safe product and complies with the regulation. All procedures described in the MOM should be addressed.
- A schedule for the accomplishment of the checklist items. Each item should be checked at least every 12 months. The organisation may choose to conduct one full review annually or to conduct several partial reviews.

- d. Performance of organisational reviews

Each checklist item should be answered using an appropriate combination of:

- review of records, documentation, etc.
- sample check of aircraft under contract or being maintained under a work order.
- interview of personnel involved.
- review of discrepancies and difficulty internal reports (e.g. notified difficulties in using current procedures and tools, systematic deviations from procedures, etc.).
- review of complaints filed by customers after delivery.

- e. Management of findings and occurrence reports.
- All findings should be recorded and notified to the affected persons.
 - All level 1 findings, in the sense of M.A.619(a), should be immediately notified to the CAA and all necessary actions on aircraft in service should be immediately taken.
 - All occurrence reports should be reviewed with the aim for continuous improvement of the system by identifying possible corrective and preventive actions. This should be done in order to find prior indicators (e.g., notified difficulties in using current procedures and tools, systematic deviations from procedures, unsafe behaviours, etc.), and dismissed alerts that, had they been recognised and appropriately managed before the event, could have resulted in the undesired event being prevented.
 - Corrective and preventive actions should be approved by the person responsible for the organisational review programme and implemented within a specified time frame.
 - Once the person responsible for the organisational review programme is satisfied that the corrective action is effective, closure of the finding should be recorded along with a summary of the corrective action.
 - The accountable manager should be notified of all significant findings and, on a regular basis, of the global results of the organisational review programme.

Following is a typical example of a simplified organisational review checklist, **to be adapted as necessary to cover the MOM procedures:**

1 - Scope of work

Check that

- All aircraft and components under maintenance or under contract are covered in the CAA Form 3.
- The scope of work in the MOM does not disagree with the CAA Form 3.
- No work has been performed outside the scope of the CAA Form 3 and the MOM.

2 - Maintenance data

- Check that maintenance data to cover the aircraft in the scope of work of the MOM are present and up-to-date.
- Check that no change has been made to the maintenance data from the TC holder without being notified.

3 - Equipment and Tools

- Check the equipment and tools against the lists in the MOM and check if still appropriate to the TC holder's instructions.
- Check tools for proper calibration (sample check).

4 - Stores

- Do the stores meet the criteria in the procedures of the MOM?
- Check by sampling some items in the store for presence of proper documentation and any overdue items.

5 - Certification of maintenance, airworthiness review

- Has maintenance on products and components been properly certified?
- Have implementation of modifications/repairs been carried out with appropriate approval of such modifications/repairs (sample check)?
- Have airworthiness reviews been properly performed and the airworthiness review certificate properly been issued?

6 - Relations with the owners/operators

- Has maintenance been carried out with suitable work orders?
- When a contract has been signed with an owner/operator, has the obligations of the contracts been respected on each side?

7 - Personnel

- Check that the current accountable manager and other nominated persons are correctly identified in the approved MOM.
- If the number of personnel has decreased or if the activity has increased, check that the staff are still adequate to ensure a safe product.
- Check that the qualification of all new personnel (or personnel with new functions) has been appropriately assessed.
- Check that the staff have been trained, as necessary, to cover changes in:
 - regulations,
 - CAA publications,
 - the MOM and associated procedures,
 - the products in the scope of work,
 - maintenance data (significant ADs, SBs, etc.).

8 - Maintenance contracted

- Sample check of maintenance records:
 - Existence and adequacy of the work order,
 - Data received from the maintenance organisation:
 - Valid CRS including any deferred maintenance,
 - List of removed and installed equipment and copy of the associated CAA Form 1 or equivalent.
- Obtain a copy of the current approval certificate (CAA Form 3) of the maintenance organisations contracted.

9 - Maintenance subcontracted

Check that subcontractors for specialised services are properly controlled by the organisation.

10 - Technical records and record-keeping

- Have the maintenance actions been properly recorded?
- Have the certificates (CAA Form 1 and Conformity certificates) been properly collected and recorded?
- Perform a sample check of technical records to ensure completeness and storage during the appropriate periods.
- Is storage of computerised data properly ensured?

11 - Occurrence reporting procedures

- Check that reporting is properly performed.
- Actions taken and recorded.

Appendix IX to AMC M.A.602 and AMC M.A.702 CAA Form 2



**Civil Aviation Authority
 Republic of Maldives**

CAA Form 2

APPLICATION FOR			
<input type="checkbox"/> MCAR-145 Approval	<input type="checkbox"/> Initial grant	<input type="checkbox"/> Change	<input type="checkbox"/> Renewal
<input type="checkbox"/> MCAR-M Subpart F Approval	<input type="checkbox"/> Initial grant	<input type="checkbox"/> Change	
<input type="checkbox"/> MCAR-M Subpart G Approval	<input type="checkbox"/> Initial grant	<input type="checkbox"/> Change	
<input type="checkbox"/> MCAR-CAMO approval	<input type="checkbox"/> Initial grant	<input type="checkbox"/> Change	
<input type="checkbox"/> MCAR-CAO approval	<input type="checkbox"/> Initial grant	<input type="checkbox"/> Change	<input type="checkbox"/> Renewal

APPLICANT DETAILS		
1. Registered name of applicant: _____		
1a. Company Registration No: _____	1b. CAA Approval Ref (if known): _____	
2. Trading Name (if different): _____		
3.1. Primary address requiring approval:		
Name/ No & Street Name: _____		
Town/City: _____	Telephone: _____	
Country: _____	Fax: _____	
Corporate E-mail: _____		
3.2. Other address requiring approval: (please use additional paper if required)		
Name/ No & Street Name: _____		
Town/City: _____	Telephone: _____	
Country: _____	Fax: _____	
4. Contact Details:		
Name: _____	Position: _____	
Tel: _____	Fax: _____	
E-mail(s): _____		
5. Terms of Approval and scope of work relevant to this application:		
Rating(s):	Limitation(s):	
1. _____	_____	
2. _____	_____	
3. _____	_____	
Approval Ref:	Regulator:	Rating(s):
1. _____	_____	_____
2. _____	_____	_____
3. _____	_____	_____
6. Name and position of the (proposed*) Accountable Manager: _____		
7. Signature of the (proposed*) Accountable Manager: _____		
8. Place: _____		
9. Date: _____		

*'proposed' applicable only in the case of new applicant

CAA Form 2, Issue 3.

SUBMISSION AND CHARGES

Please submit the completed application form to Maldives Civil Aviation Authority, 2ndFloor Velaanaage, Ameeru Ahmed Magu, Male',20096, Republic of Maldives together with MRF/US\$ being the fee payable in accordance with MCAR-187.

Invoice/ Receipt No: _____	Date: _____	CAA use only
----------------------------	-------------	---------------------

TERMS OF APPROVAL AVAILABLE

CLASS AIRCRAFT	RATING	LIMITATION	BASE	LINE
	A1 Aeroplanes above 5700 kg	[Rating reserved to Maintenance Organisations approved in accordance with MCAR-145] [State aeroplane manufacturer or group or series or series or type and/or the maintenance tasks] Example: Airbus A320 Series	YES <input type="checkbox"/> NO <input type="checkbox"/>	YES <input type="checkbox"/> NO <input type="checkbox"/>
	A2 Aeroplanes 5700 kg and below	[State aeroplane manufacturer or group or series or type and/or the maintenance tasks] Example: DHC-6 Twin Otter Series State whether the issue of airworthiness review certificates is requested or not involved in commercial operations)	YES <input type="checkbox"/> NO <input type="checkbox"/>	YES <input type="checkbox"/> NO <input type="checkbox"/>
	A3 Helicopters	[State helicopter manufacturer or group or series or type and/or the maintenance task(s)] Example: Robinson R44	YES <input type="checkbox"/> NO <input type="checkbox"/>	YES <input type="checkbox"/> NO <input type="checkbox"/>
	A4 Aircraft other than A1, A2 and A3	[State aircraft category (sailplane, balloon, airship, etc.), manufacturer or group or series or type and/or the maintenance task(s).] State whether the issue of airworthiness review certificate is requested or not (only possible for ELA1 aircraft not involved in commercial operations)	YES <input type="checkbox"/> NO <input type="checkbox"/>	YES <input type="checkbox"/> NO <input type="checkbox"/>
ENGINES	B1 Turbine	[State engine series or type and/or the maintenance task(s)] Example: PT6A Series		
	B2 Piston	[State engine manufacturer or group or series or type and/or the maintenance task(s)]		
	B3 APU	[State engine manufacturer or series or type and/or the maintenance task(s)]		
COMPONENTS OTHER THAN COMPLETE ENGINES OR APUs	C1 Air Cond & Press	[State aircraft type or aircraft manufacturer or component manufacturer or the particular component and/or cross refer to a capability list in the exposition and/or the maintenance task(s).] Example: PT6A Fuel Control		
	C2 Auto Flight			
	C3 Comms and Nav			
	C4 Doors - Hatches			
	C5 Electrical Power & Lights			
	C6 Equipment			
	C7 Engine - APU			
	C8 Flight Controls			
	C9 Fuel			
	C10 Helicopter - Rotors			
	C11 Helicopter - Trans			
	C12 Hydraulic Power			
	C13 Indicating-recording system			
	C14 Landing Gear			
	C15 Oxygen			
	C16 Propellers			
	C17 Pneumatic & Vacuum			
	C18 Protection ice/ rain/fire			
	C19 Windows			
	C20 Structural			
	C21 Water ballast			
	C22 Propulsion Augmentation			
SPECIALISED SERVICES	D1 Non-Destructive Testing	[State particular NDT method(s)]		

CAA Form 2, Issue 2.1, 01 June 2019

Appendix X CAA Form 4



**Civil Aviation Authority
Republic of Maldives**

CAA Form 4

This form can be completed online, then printed and signed. If filled in by hand, please use black or dark blue ink.

Details of Management Personnel required to be accepted as specified in MCAR-_____	
1. Title / Name:	_____
2. Position within the Organisation:	_____
3. Qualifications relevant to the item (2) position:	<div style="border: 1px dotted black; height: 60px;"></div>
4. Work experience relevant to the item (2) position:	<div style="border: 1px dotted black; height: 60px;"></div>
5. Organisation:	_____
6. Approval Number relevant to the item (5):	_____
Signature: _____	Date: _____

CAA use only:	
Name(s) and signature(s) of authorised Civil Aviation Authority staff member(s) accepting this person:	
<i>Flight Operations</i>	<i>Airworthiness</i>
Signature _____	Signature _____
Name _____	Name _____
Date _____	Date _____
<i>Once authorised, a copy of the completed CAA Form 4 must be returned to the nominee.</i>	

CAA Form 4, Issue 4.01, 01 June 2019

Appendix XI to AMC to M.A.708(c) - Contracted Maintenance

1. Maintenance contracts

The following paragraphs are not intended to provide a standard maintenance contract, but to provide a list of the main points that should be addressed, when applicable, in a maintenance contract between the CAMO managing aircraft subject to MCAR-M and a maintenance organisation approved in accordance with MCAR-145 or Subpart F of MCAR-. The following paragraphs only address technical matters and exclude matters such as costs, delay, warranty, etc.

When maintenance is contracted to more than one maintenance organisation (for example, aircraft base maintenance to X, engine maintenance to Y, and line maintenance to Z1, Z2 and Z3), attention should be paid to the consistency of the different maintenance contracts.

A maintenance contract is not normally intended to provide appropriate detailed work instructions to personnel. Accordingly, there should be established organisational responsibilities, procedures and routines in the CAMO and the maintenance organisation to cover these functions in a satisfactory way such that any person involved is informed about his/her responsibilities and the procedures that apply. These procedures and routines can be included/appended to the CAME and to the maintenance organisation's manual/MOE, or can consist in separate procedures. In other words, procedures and routines should reflect the conditions of the contract.

2. Aircraft/Engine maintenance

The following subparagraphs may be adapted to a maintenance contract that applies to aircraft base maintenance, aircraft line maintenance and engine maintenance.

Aircraft maintenance also includes the maintenance of the engines and APU while they are installed on the aircraft.

2.1 Scope of work

The type of maintenance to be performed by the maintenance organisation should be specified unambiguously. In case of line and/or base maintenance, the contract should specify the aircraft type and, preferably, should include the aircraft's registrations.

In case of engine maintenance, the contract should specify the engine type.

2.2 Locations identified for the performance of maintenance/ Certificates held

The place(s) where base, line or engine maintenance, as applicable, will be performed should be specified. The certificate held by the maintenance organisation at the place(s) where maintenance will be performed should be referred to in the contract. If necessary, the contract may address the possibility of performing maintenance at any location subject to the need for such maintenance arising either from the unserviceability of the aircraft or from the necessity of supporting occasional line maintenance.

2.3 Subcontracting

The maintenance contract should specify under which conditions the maintenance organisation may subcontract tasks to a third party (regardless if this third party is approved or not). At least the

contract should make reference to M.A.615 and 145.A.75. Additional guidance is provided by the associated AMC/GM. In addition, the CAMO may require the maintenance organisation to obtain the CAMO approval before subcontracting to a third party. Access should be given to the CAMO to any information (especially the quality monitoring information) about the maintenance organisation's subcontractors involved in the contract. It should, however, be noted that under the CAMO responsibility both the CAMO and its CAA are entitled to be fully informed about subcontracting, although the CAA will normally only be concerned with aircraft, engine and APU subcontracting.

2.4 Maintenance programme

The maintenance programme, under which the maintenance has to be performed, has to be specified.

The CAMO should have that maintenance programme approved by the CAA.

2.5 Quality monitoring

The terms of the contract should include a provision allowing the CAMO to perform a quality surveillance (including audits) of the maintenance organisation. The maintenance contract should specify how the results of the quality surveillance are taken into account by the maintenance organisation (See also paragraph 2.22. 'Meetings').

2.6 CAA involvement

The contract should identify the CAA for the oversight of the aircraft, the operator, the CAMO, the maintenance organisation. Additionally, the contract should allow the CAA to access the maintenance organisation.

2.7 Maintenance data

The contract should specify the maintenance data and any other manual required for the fulfilment of the contract, and how these data and manuals are made available and kept current (regardless if they are provided by the CAMO or by the maintenance organisation).

This may include but is not limited to:

- maintenance programme,
- airworthiness directives,
- major repairs/modification data,
- aircraft maintenance manual,
- aircraft illustrated parts catalogue (IPC),
- wiring diagrams,
- troubleshooting manual,

- Minimum Equipment List (normally on board the aircraft),
- operator’s manual,
- flight manual,
- engine maintenance manual,
- engine overhaul manual.

2.8 Incoming Conditions

The contract should specify in which condition the aircraft should be made available to the maintenance organisation. For extensive maintenance, it may be beneficial that a work scope planning meeting be organised so that the tasks to be performed may be commonly agreed (see also paragraph 2.23: ‘Meetings’).

2.9 Airworthiness Directives and Service Bulletins/Modifications

The contract should specify the information that the CAMO is responsible to provide to the maintenance organisation, such as:

- status of the ADs including the due date and the selected means of compliance, if applicable; and
- status of modifications and decision to embody a modification or an SB.

In addition, the contract should specify the type of information the CAMO will need in return to complete the control of ADs and modification status.

2.10 Hours & Cycles control

Hours and cycles control is the responsibility of the CAMO, and the contract should specify how the CAMO should provide the current hours and cycles to the maintenance organisation and whether the maintenance organisation should receive the current flight hours and cycles on a regular basis so that it may update the records for its own planning functions (see also paragraph 2.22: ‘Exchange of information’).

2.11 Life-limited parts and time-controlled components

The control of life-limited parts and time-controlled components is the responsibility of the CAMO. The contract should specify whether the CAMO should provide the status of life-limited parts and time-controlled components to the maintenance organisation, and the information that the approved organisation will have to provide to the CAMO about removal/installation of the life-limited parts and time-controlled components removal/installation so that the CAMO may update its records (see also paragraph 2.22 ‘Exchange of information’).

2.12 Supply of parts

The contract should specify whether a particular type of material or component is supplied by the CAMO or by the maintenance organisation, which type of component is pooled, etc. The contract

should clearly state that it is the maintenance organisation's responsibility to be in any case satisfied that the component in question meets the approved data/standard and to ensure that the aircraft component is in a satisfactory condition for installation. Additional guidance on the acceptance of components is provided in M.A.402 and 145.A.42.

2.13 Pooled parts at line stations

If applicable, the contract should specify how the subject of pooled parts at line stations should be addressed.

2.14 Scheduled maintenance

For planning scheduled maintenance checks, the support documentation to be given to the maintenance organisation should be specified. This may include but is not limited to:

- applicable work package, including job cards;
- scheduled component removal list;
- modifications to be incorporated.

When the maintenance organisation determines, for any reason, to defer a maintenance task, it has to be formally agreed with the CAMO. If the deferment goes beyond an approved limit, please refer to paragraph 2.17 'Deviation from the maintenance schedule'. This should be addressed, where applicable, in the maintenance contract.

2.15 Unscheduled maintenance/Defect rectification

The contract should specify to which level the maintenance organisation may rectify a defect without reference to the CAMO. It should describe, as a minimum, the management of approval of repairs and incorporation of major repairs. The deferment of any defect rectification should be submitted to the CAMO.

2.16 Deferred tasks

See paragraphs 2.14 and 2.15 above and AMC 145.A.50 (e) and M.A.801(g). In addition, for aircraft line and base maintenance, the use of the operator's MEL and the liaison with the CAMO in case of a defect that cannot be rectified at the line station should be addressed.

2.17 Deviation from the maintenance schedule

Deviations from the maintenance schedule have to be managed by the CAMO in accordance with the procedures established in the maintenance programme. The contract should specify the support the maintenance organisation may provide to the operator in order to substantiate the deviation request.

2.18 Maintenance check flight

If any maintenance check test flight is required after aircraft maintenance, it should be performed in accordance with the procedures established in the continuing airworthiness management exposition or the operator's manual.

2.19 Bench Test

The contract should specify the acceptability criterion and whether a representative of the CAMO should witness an engine undergoing test.

2.20 Release to service documentation

The release to service has to be performed by the maintenance organisation in accordance with its maintenance organisation procedures. The contract should, however, specify which support forms have to be used (aircraft technical log, maintenance organisation's release format, etc.) and the documentation that the maintenance organisation should provide to the CAMO upon delivery of the aircraft. This may include but is not limited to:

- certificate of release to service,
- flight test report,
- list of modifications embodied,
- list of repairs,
- list of ADs incorporated,
- maintenance visit report,
- test bench report.

2.21 Maintenance record-keeping

The CAMO may subcontract the maintenance organisation to retain some of the maintenance records required by MCAR-M Subpart C. This means that the CAMO subcontracts under its quality system part of its record-keeping tasks and, therefore, the provisions of M.A.711(a)(3) apply.

2.22 Exchange of information

Each time exchange of information between the CAMO and the maintenance organisation is necessary, the contract should specify what information should be provided and when (i.e. in which case or at what frequency), how, by whom and to whom it has to be transmitted.

2.23 Meetings

The maintenance contract should include the provision for a certain number of meetings to be held between the CAMO and the maintenance organisation.

2.23.1 Contract review

Before the contract is enforced, it is very important that the technical personnel of both parties, that are involved in the fulfilment of the contract, meet in order to be sure that every point leads to a common understanding of the duties of both parties.

2.23.2 Work scope planning meeting

Work scope planning meetings may be organised so that the tasks to be performed may be commonly agreed.

2.23.3 Technical meeting

Scheduled meetings may be organised in order to review on a regular basis technical matters such as ADs, SBs, future modifications, major defects found during maintenance check, aircraft and component reliability, etc.

2.23.4 Quality meeting

Quality meetings may be organised in order to examine matters raised by the CAMO's quality surveillance and to agree upon necessary corrective actions.

2.23.5 Reliability meeting

When a reliability programme exists, the contract should specify the CAMO's and maintenance organisation's respective involvement in that programme, including the participation in reliability meetings.

Appendix XII to AMC M.A.706(f) Fuel Tank Safety training

This appendix includes general instructions for providing training on Fuel Tank Safety issues.

A) Effectivity:

- Large aeroplanes as defined in MCAR-1.

B) Affected organisations:

- CAMOs involved in the continuing airworthiness management of aeroplanes specified in paragraph A).

CAA when responsible for the oversight as per M.B.704 of aeroplanes specified in paragraph A) and for the oversight of the CAMO specified in this paragraph B).

C) Persons from affected organisations who should receive training:

Phase 1 only:

- The quality manager and quality personnel.

Personnel of the CAA responsible for the oversight as per M.B.704 of aeroplanes specified in paragraph A) and in the oversight of CAMOs specified in paragraph B).

Phase 1 + Phase 2 + Continuation training:

- Personnel of the CAMO involved in the management and review of the continuing airworthiness of aircraft specified in paragraph A);

D) General requirements of the training courses

Phase 1 – Awareness

The training should be carried out before the person starts to work without supervision but not later than 6 months after joining the organisation. The persons who have already attended the Level 1 Familiarisation course in compliance with EASA ED decision 2007/001/R Appendix XII are already in compliance with Phase 1.

Type: Should be an awareness course with the principal elements of the subject. It may take the form of a training bulletin, or other self-study or informative session. Signature of the reader is required to ensure that the person has passed the training.

Level: It should be a course at the level of familiarisation with the principal elements of the subject.

Objectives:

The trainee should, after the completion of the training:

1. Be familiar with the basic elements of the fuel tank safety issues.

2. Be able to give a simple description of the historical background and the elements requiring a safety consideration, using common words and showing examples of non-conformities.
3. Be able to use typical terms.

Content: The course should include:

- a short background showing examples of FTS accidents or incidents,
- the description of concept of fuel tank safety and CDCCL,
- some examples of manufacturers documents showing CDCCL items,
- typical examples of FTS defects,
- some examples of TC holders repair data
- some examples of maintenance instructions for inspection.

Phase 2 - Detailed training

A flexible period may be allowed by the CAA to allow organisations to set the necessary courses and impart the training to the personnel, taking into account the organisation's training schemes/means/practices. This flexible period should not extend beyond 31 December 2010.

The persons who have already attended the Level 2 Detailed training course in compliance with EASA ED decision 2007/001/R Appendix XII either from a CAMO or from a Part-147 training organisation are already in compliance with Phase 2 with the exception of continuation training.

Staff should have received Phase 2 training by 31 December 2010 or within 12 months of joining the organization, whichever comes later.

Type: Should be a more in-depth internal or external course. It should not take the form of a training bulletin or other self-study. An examination should be required at the end, which should be in the form of a multi choice question, and the pass mark of the examination should be 75%.

Level: It should be a detailed course on the theoretical and practical elements of the subject.

The training may be made either:

- in appropriate facilities containing examples of components, systems and parts affected by Fuel Tank Safety (FTS) issues. The use of films, pictures and practical examples on FTS is recommended; or
- by attending a distance course (e-learning or computer based training) including a film when such film meets the intent of the objectives and content here below. An e-learning or computer based training should meet the following criteria:
 - A continuous evaluation process should ensure the effectiveness of the training and its relevance;

- Some questions at intermediate steps of the training should be proposed to ensure that the trainee is authorized to move to the next step;
- The content and results of examinations should be recorded;
- Access to an instructor in person or at distance should be possible in case support is needed.

A duration of 8 hours for phase 2 is an acceptable compliance.

When the course is provided in a classroom, the instructor should be very familiar with the data in Objectives and Guidelines. To be familiar, an instructor should have attended himself a similar course in a classroom and made additionally some lecture of related subjects.

Objectives:

The attendant should, after the completion of the training:

- have knowledge of the history of events related to fuel tank safety issues and the theoretical and practical elements of the subject, have an overview of the FAA regulations known as SFAR (Special FAR) 88 of the FAA and of JAA Temporary Guidance Leaflet TGL 47, be able to give a detailed description of the concept of fuel tank system ALI (including Critical Design Configuration Control Limitations CDCCL, and using theoretical fundamentals and specific examples;
- have the capacity to combine and apply the separate elements of knowledge in a logical and comprehensive manner;
- have knowledge on how the above items affect the aircraft;
- be able to identify the components or parts of the aircraft subject to FTS from the manufacturer's documentation,
- be able to plan the action or apply a Service Bulletin and an Airworthiness Directive.

Content: Following the guidelines described in paragraph E).

Continuation training:

The organisation should ensure that the continuation training is performed in each two years period. The syllabus of the training programme referred to in the Training policy of the Continuing Airworthiness Management Exposition (CAME) should contain the additional syllabus for this continuation training.

The continuation training may be combined with the phase 2 training in a classroom or at distance.

The continuing training should be updated when new instructions are issued which are related to the material, tools, documentation and manufacturer's or CAA's directives.

E) Guidelines for preparing the content of Phase 2 courses.

The following guidelines should be taken into consideration when the phase 2 training programme are being established:

- a) understanding of the background and the concept of fuel tank safety,
- b) how the mechanics can recognise, interpret and handle the improvements in the instructions for continuing airworthiness that have been made or are being made regarding fuel tank systems,
- c) awareness of any hazards especially when working on the fuel system, and when the Flammability Reduction System using nitrogen is installed.

Paragraphs a), b) and c) above should be introduced in the training programme addressing the following issues:

- i) The theoretical background behind the risk of fuel tank safety: the explosions of mixtures of fuel and air, the behaviour of those mixtures in an aviation environment, the effects of temperature and pressure, energy needed for ignition, etc, the 'fire triangle', - Explain 2 concepts to prevent explosions:
 - (1) ignition source prevention and
 - (2) flammability reduction,
- ii) The major accidents related to fuel tank systems, the accident investigations and their conclusions,
- iii) SFAR 88 of the FAA and JAA Interim Policy INT POL 25/12: ignition prevention program initiatives and goals, to identify unsafe conditions and to correct them, to systematically improve fuel tank maintenance),
- iv) Explain briefly the concepts that are being used: the results of SFAR 88 of the FAA and JAA INT/POL 25/12: modifications, airworthiness limitations items and CDCCL,
- v) Where relevant information can be found and how to use and interpret this information in the applicable maintenance data as defined in M.A.401(b),
- vi) Fuel Tank Safety during maintenance: fuel tank entry and exit procedures, clean working environment, what is meant by configuration control, wire separation, bonding of components etc.,
- vii) Flammability reduction systems when installed: reason for their presence, their effects, the hazards of a Flammability Reduction System (FRS) using nitrogen for maintenance, safety precautions in maintenance/working with an FRS,
- viii) Recording maintenance actions, recording measures and results of inspections.

The training should include a representative number of examples of defects and the associated repairs as required by the TC / STC holders maintenance data.

F) Approval of training

For CAMOs the approval of the initial and continuation training programme and the content of the examination can be achieved by the change of the CAME exposition. The modification of the CAME should be approved as required by M.A.704(b). The necessary changes to the CAME to meet the content of this decision should be made and implemented at the time requested by the CAA.

Appendix XIII to AMC M.A.712(f) Organisational review

The following text provides relevant information for conducting organisational reviews in accordance with M.A.712 for the particular case of a CAMO working on aircraft subject to MCAR-M.

Organisational reviews may replace a full quality system in accordance with the provisions of M.A.712(f) and AMC M.A.712(f) and as described in the continuing airworthiness management exposition (CAME)

Depending on the complexity of the small organisation (number and type of aircraft, number of different fleets, privilege to perform airworthiness reviews, etc.), the organisational review system may vary from a system using the principles and practices of a quality system (except for the requirement of independence) to a simplified system adapted to the low complexity of the organisation and the aircraft managed.

As a core minimum, the organisational review system should have the following features, which should be described in the CAME:

a. Identification of the person responsible for the organisational review programme:

By default, this person should be the accountable manager, unless he delegates this responsibility to (one of) the M.A.706(c) person(s).

b. Identification and qualification criteria for the person(s) responsible for performing the organisational reviews:

These persons should have a thorough knowledge of the regulations and of the continuing airworthiness management organisation (CAMO) procedures. They should also have knowledge of audits, acquired through training or through experience (preferably as an auditor, but also possibly because they actively participated in several audits conducted by the CAA).

c. Elaboration of the organisational review programme:

- Checklist(s) covering all items necessary to be satisfied that the organisation delivers a safe product and complies with the regulation. All procedures described in the CAME should be addressed.
- A schedule for the accomplishment of the checklist items. Each item should be checked at least every 12 months. The organisation may choose to conduct one full review annually or to conduct several partial reviews.

d. Performance of organisational reviews:

Each checklist item should be answered using an appropriate combination of:

- review of records, documentation, etc.
- sample check of aircraft under contract.
- interview of personnel involved.

- review of discrepancies and difficulty internal reports (e.g., notified difficulties in using current procedures and tools, systematic deviations from procedures, etc.).
 - review of complaints filed by customers.
- e. Management of findings and occurrence reports:
- All findings should be recorded and notified to the affected persons.
 - All level 1 findings, in the sense of M.A.716(a), should be immediately notified to the CAA and all necessary actions on aircraft in service should be immediately taken.
 - All occurrence reports should be reviewed with the aim for continuous improvement of the system by identifying possible corrective and preventive actions. This should be done in order to find prior indicators (e.g., notified difficulties in using current procedures and tools, systematic deviations from procedures, unsafe behaviours, etc.), and dismissed alerts that, had they been recognised and appropriately managed before the event, could have resulted in the undesired event being prevented.
 - Corrective and preventive actions should be approved by the person responsible for the organisational review programme and implemented within a specified time frame.
 - Once the person responsible for the organisational review programme is satisfied that the corrective action is effective, closure of the finding should be recorded along with a summary of the corrective action.
 - The accountable manager should be notified of all significant findings and, on a regular basis, of the global results of the organisational review programme.

Following is a typical example of a simplified organisational review checklist, **to be adapted as necessary to cover the CAME procedures:**

1 - Scope of work

- All aircraft under contract are covered in the CAA Form 14.
- The scope of work in the CAME does not disagree with the CAA Form 14.
- No work has been performed outside the scope of the CAA Form 14 and the CAME.
- Is it justified to retain in the approved scope of work aircraft types for which the organisation has no longer aircraft under contract?

2 - Airworthiness situation of the fleet

- Does the continuing airworthiness status (AD, maintenance programme, life limited components, deferred maintenance, ARC validity) show any expired items? If so, are the aircraft grounded?

3 - Aircraft maintenance programme

- Check that all revisions to the TC/STC holders Instructions for Continuing Airworthiness, since the last review, have been (or are planned to be) incorporated in the maintenance programme, unless otherwise approved by the CAA.
- Has the maintenance programme been revised to take into account all modifications or repairs impacting the maintenance programme?
- Have all maintenance programme amendments been approved at the right level (CAA or indirect approval)?
- Does the status of compliance with the maintenance programme reflect the latest approved maintenance programme?
- Has the use of maintenance programme deviations and tolerances been properly managed and approved?

4 - Airworthiness Directives (and other mandatory measures issued by the CAA)

- Have all ADs issued since the last review been incorporated into the AD status?
- Does the AD status correctly reflect the AD content: applicability, compliance date, periodicity...? (sample check on ADs)

5 - Modifications/repairs

- Are all modifications/repairs listed in the corresponding status approved in accordance with M.A.304? (sample check on modifications/repairs)
- Have all the modifications/repairs which have been installed since the last review been incorporated in the corresponding status? (sample check from the aircraft/component logbooks)

6 - Relations with the owners/operators

- Has a contract (in accordance with Annex I to MCAR-M) been signed with each external owner/operator, covering all the aircraft whose airworthiness is managed by the CAMO?
- Have the owners/operators under contract fulfilled their obligations identified in the contract?
As appropriate:
 - Are the pre-flight checks correctly performed? (interview of pilots)
 - Are the technical log or equivalent correctly used (record of flight hours/cycles, defects reported by the pilot, identification of what maintenance is next due etc.)?
 - Did flights occur with overdue maintenance or with defects not properly rectified or deferred? (sample check from the aircraft records)

- Has maintenance been performed without notifying the CAMO (sample check from the aircraft records, interview of the owner/operator)?

7 - Personnel

- Check that the current accountable manager and other nominated persons are correctly identified in the approved CAME.
- If the number of personnel has decreased or if the activity has increased, check that the organisation still has sufficient staff.
- Check that the qualification of all new personnel (or personnel with new functions) has been appropriately assessed.
- Check that the staff has been trained, as necessary, to cover changes in:
 - regulations,
 - CAA publications,
 - the CAME and associated procedures,
 - the approved scope of work,
 - maintenance data (significant ADs, SBs, ICA amendments, etc.).

8 - Maintenance contracted

- Sample check of maintenance records:
 - Existence and adequacy of the work order,
 - Data received from the maintenance organisation:
 - Valid CRS including any deferred maintenance
 - List of removed and installed equipment and copy of the associated CAA Form 1 or equivalent.
- Obtain a copy of the current approval certificate (CAA Form 3) of the maintenance organisations contracted.

9 - Technical records and record-keeping

- Have the certificates (CAA Form 1 and Conformity certificates) been properly collected and recorded?
- Perform a sample check of technical records to ensure completeness and storage during the appropriate periods.
- Is storage of computerised data properly ensured?

10 - Occurrence reporting procedures

- Check that reporting is properly performed,
- Actions taken and recorded.

11 - Airworthiness review
